



ROEMHELD
HILMA ■ STARK

Issue 9-15 E

B 1.8241

Slide Pivot Clamps with optional position monitoring double acting, max. operating pressure 500 bar



Description

In the case of the slide pivot clamp the piston force is deviated by 180° by the clamping lever and is available as clamping force with virtually no loss of efficiency. Kinematics of the slide pivot clamp allow sliding back of the clamping lever during unclamping for unimpeded insertion of the workpieces.

The clamping lever is available with smooth swivel contact bolt and in a longer version with dome-head contour.

The position of the clamping lever can be monitored by inductive proximity switches or pneumatic jets.

The pivot slide clamp can be installed immersed up to the flange surface in a hole of the fixture body or via intermediate plates which are available as an accessory. For both solutions there is the possibility to supply the hydraulic oil not only by fitting connection but also via drilled channels in the fixture body.

Important notes!

Slide pivot clamps must only be used for clamping of workpieces in industrial applications and may only be operated with hydraulic oil. They can generate very high forces. The workpiece, the fixture or the machine must be in the position to compensate these forces.

In the effective area of piston rod and clamping lever there is the danger of crushing. The manufacturer of the fixture or the machine is obliged to provide effective protection devices.

The clamping lever must not be impeded during swivelling movement. The slots of the sliding pad have to be checked from time to time with regard to contamination by swarf and cleaned, if required.

Operating conditions, tolerances and other data see data sheet A 0.100.

Advantages

- 3 sizes
- High clamping force, up to 50 kN
- Minimum dimensions
- High efficiency
- Minimum side loads act on the workpiece in the clamping area
- Increased rigidity allows compensation of side loads at the clamping point
- Unimpeded loading and unloading of the fixture
- Inductive or pneumatic monitoring of the clamping lever available as accessory
- Monitoring of the unclamping position and the usable clamping range is possible
- Two different clamping levers are available
- Clamping lever can be swivelled into small recesses
- Partially immersed mounting of the body
- Oil supply alternatively via fittings or drilled channels

Application

The slide pivot clamp has in relation to its base a very high clamping force. The clamps are particularly suitable for clamping tasks on machines with high performance and reduced space availability on the fixture. The workpieces can be inserted from above without any impediments. A clamping recess a little bit wider than the clamping lever is sufficient as clamping surface. This characteristic indicates their use for clamping of aluminium parts, which are very sensitive against deformation, with correspondingly reduced oil pressure.

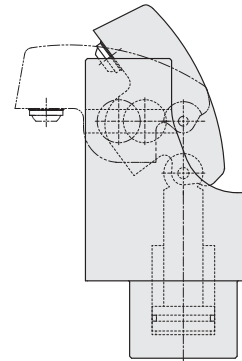

Connecting and installation possibilities Pipe thread

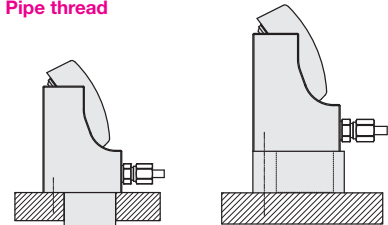

Drilled channels

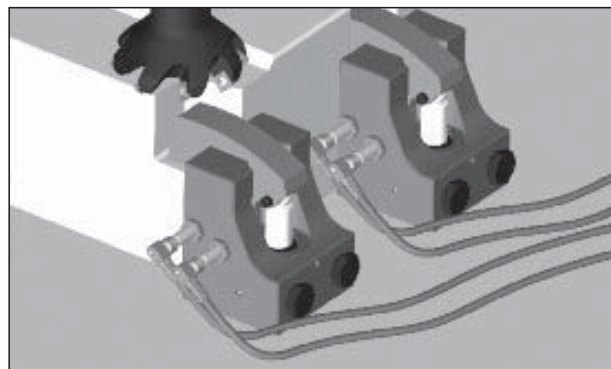
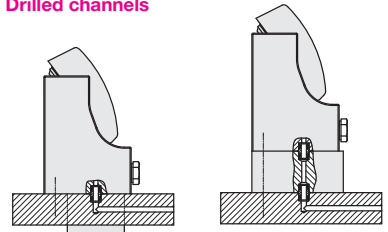

Accessory

Version with long clamping lever

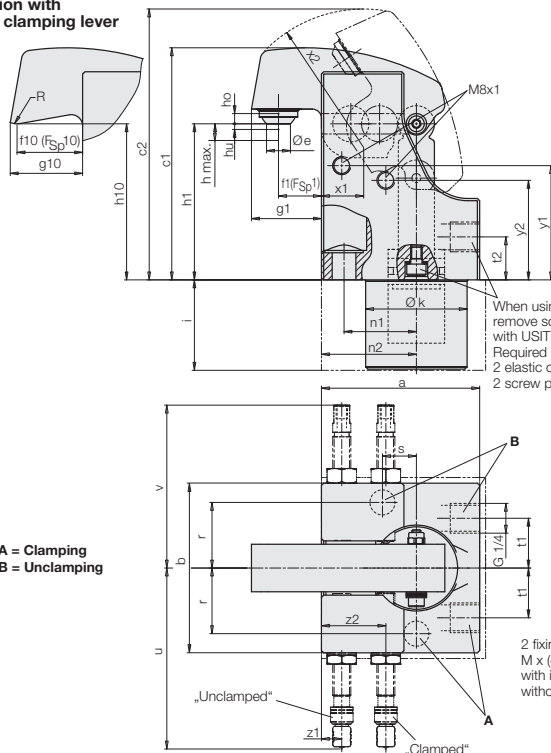

A = Clamping
B = Unclamping

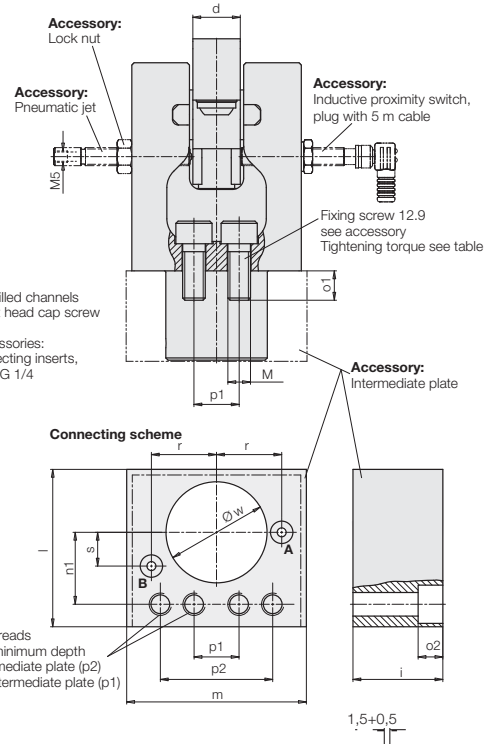

Bore hole for elastic connecting insert

For oil supply through drilled channels, two bore holes have to be provided in the base plate for elastic connecting inserts.

Clamping force F_{Sp1} / F_{Sp10} at 500 bar	[kN]	20 / 15	32 / 23	50 / 37
Oil volume clamping	[cm ³]	14	25	49
Oil volume unclamping	[cm ³]	8	15	30
a	[mm]	70	84	99
b	[mm]	75	97	113
c1 / c2	[mm]	103 / 120	120 / 141.5	150 / 175
d	[mm]	21	29	33
$\varnothing e$	[mm]	10	10	20
f1 / f10	[mm]	19 / 29	20 / 34	25 / 40
g1 / g10	[mm]	31 / 32	36 / 37	44 / 45
h1 / h10	[mm]	69	81.5	101.5
ho / hu, upper / lower clamping point	[mm]	4.5 / 2.5	5.0 / 3.0	6.0 / 3.5
h max.	[mm]	4	4.5	6.2
i	[mm]	40	40	40
$\varnothing k$	[mm]	44.9	54.9	59.9
l	[mm]	70	88	100
m	[mm]	80	100	120
M, socket head cap screw DIN912 / tightening torque	[Nm]	M10 / 87	M12 / 150	M16 / 370
n1 / n2	[mm]	32 / 42	39 / 50	47 / 62
o1 / o2	[mm]	13 / 11	15 / 13	16 / 17
p1 / p2	[mm]	20 / 50	30 / 64	28 / 72
r ± 0.02	[mm]	29	35	38
R	[mm]	8	10	12
s ± 0.02	[mm]	15	20	20
t1 / t2	[mm]	22 / 19	26 / 20	35 / 29
u, approx.	[mm]	78	82	94
v, approx.	[mm]	72	76	78
$\varnothing w +0.1$, mounting hole	[mm]	45	55	60
x1 / x2	[mm]	18.7 / 61.5	22 / 70	28 / 88
y1 / y2	[mm]	50.5 / 44	59 / 57	73 / 68
z1 / z2	[mm]	9 / 28.5	9 / 33	9.5 / 37
Weight approx.	[kg]	3.0	5.6	9.3
Part no. with swivel contact bolt		1824-061	1824-111	1824-161
Part no. with long clamping lever		1824-081	1824-131	1824-181

Function chart

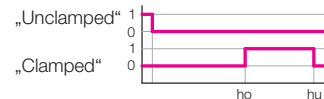

Accessories:

Accessories:	Part no.
Screw plug G 1/4	3610-264
Elastic connecting insert**	9210-132
2 off required without intermediate plate, or 4 off with intermediate plate	
Inductive proximity switch*	3829-164
Right angle plug with 5 m cable*	3829-099
Pneumatic jet	3612-020
Lock nut	3301-566
Intermediate plate for 1824-061,-081	3456-384
Socket head cap screw	
DIN EN ISO 4762-M10x45 12.9 2 off	3300-253
Intermediate plate for 1824-111,-131	3456-385
Socket head cap screw	
DIN EN ISO 4762-M12x45 12.9 2 off	3300-765
Intermediate plate for 1824-161,-181	3456-386
Socket head cap screw	
DIN EN ISO 4762-M16x50 12.9 2 off	3300-264

* Technical data
see data sheet B 1.7384, page 6
** see data sheet F 9.300, page 3