

Industrial
Hydraulics

Electric Drives
and Controls

Linear Motion and
Assembly Technologies

Pneumatics

Service
Automation

Mobile
Hydraulics

Rexroth
Bosch Group

Hydraulic drive power unit Low-noise compact unit “Whispering power unit“

RE 51094/05.04 1/12
Replaces: 08.03

Type ABFAG-V

Component series 1X
Reservoir volume 160-1000 litres
Vertical design

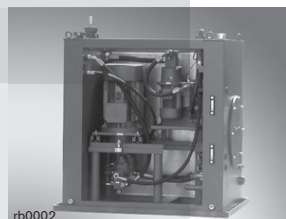

Type ABFAG-V ...open



Type ABFAG-V ...enclosed

Table of contents

Contents	Page
Features	1
Ordering code	2
Function	2
Circuit diagram	3
Technical data	4
Selection table	5
Mounting of components	6
Connection sizes for flanges and fittings	6
Typical noise values	7
Spare filter elements	7
Float switch settings	7
Unit dimensions	8, 9
Oil trip tray to Water Resources Act	10
Engineering and commissioning notes	11

Features

- Extremely low-noise compact unit
- Fields of application:
 - General machinery construction sector
 - Plastics processing machinery
 - Lifting and elevator equipment
 - Press construction sector
 - Laboratories, schools
- U-shaped tank with motor-pump group fitted using anti-vibration mounts
- Actuator ports terminate at a flexibly supported outlet strip
- Good outgassing of the hydraulic fluid
- Separate filtering-cooling circuit
- Excellent accessibility

Circuit diagram: Whispering power unit, U-shape

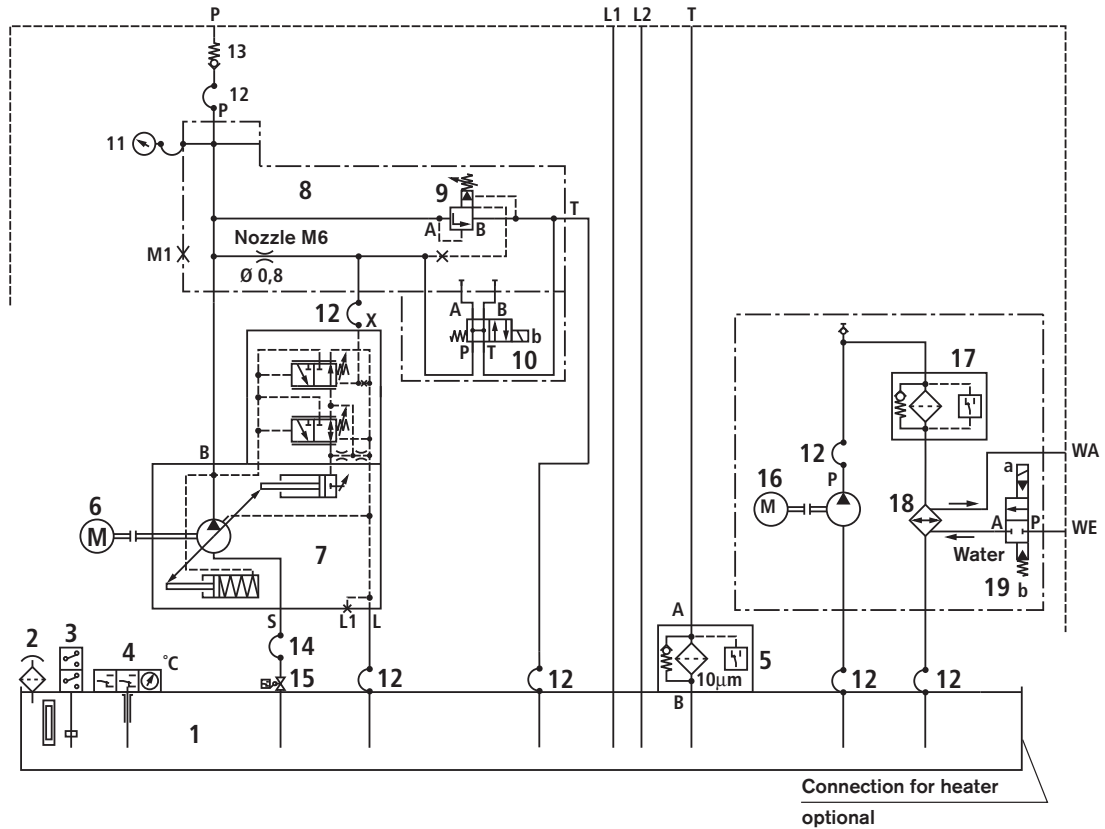

- | | |
|---------------------------------|---|
| 1 Fluid tank | 11 Pressure gauge |
| 2 Tank breather filter | 12 Hoses |
| 3 Float switch | 13 Check valve |
| 4 Thermostat with indicator | 14 Suction hose |
| 5 Return line filter | 15 Check flap with monitoring of the position |
| 6 Electric motor | 16 Pump-motor group |
| 7 Axial piston pump | 17 Line filter |
| 8 Maximum pressure relief block | 18 oil/water cooler |
| 9 Pressure relief valve | 19 Water valve, electrical |
| 10 Directional valve | |

Technical data (for applications outside these parameters, please consult us!)

Line connections	- Oil side	Connection thread to ISO 1179, pipe connections to DIN 2353/ ISO 8434, flanges to ISO 6162
	- Water connections	Pipe thread to ISO 228/1
Pump types		A10VSO 18 to data sheet RE 92712
		A10VSO 28 ... 140 to data sheet RE 92711
	- Circulating unit	PVW 18 ... 60 to data sheet RE 10335 ¹⁾
Type of pipe fittings		Fittings to DIN 2353; light/heavy series; type Walform
Hydraulic fluid		Mineral oil (HL, HLP) to DIN 51524; fast bio-degradable hydraulic fluids to VDMA 24 568 (see also RE 90221); HETG (rape-seed oil); HEPG (polyglycols); HEES (synthetic esters) and other hydraulic fluids on enquiry. Please observe our regulations given in data sheet RE 07075.
Hydraulic fluid temperature range	°C	0 ... + 80 The optimum operating temperature of the power unit in operation with mineral oil HLP to DIN 51524 is between 40 and 50 °C. The operating temperature should not exceed 70 °C in continuous operation.
Max. pressure relief function		Pump pressure relief valve to data sheet RE 25890 for variable displacement pumps of type A10VSO
Cooling medium		Potable, processing water, water from streams and rivers
Motor voltage / frequency		400/690 V-D/Y-50 Hz; 460 V-D-60 Hz (other voltages on enquiry); form B 35
Pump's direction of rotation		Clockwise
Water valve		Electrically operated 2/2 directional water valve to AB 21-23
Viscosity range	- optimum	mm ² /s 16 ... 36
	- briefly	mm ² /s 10 ... 1000 (see also RE 92711; 92712 and RE 10335)
Cleanliness classes in accordance with ISO code		Max. permissible degree of contamination of the hydraulic fluid to ISO 4406 (c) class 21/18/15 ²⁾
Filter rating	µm	10
Surface protection	- 1st primer coat	All steel components with zinc dust paint
	- 2nd primer coat	Epoxy primer to RAL 5010 (RN 123.01)

¹⁾ Other pumps on enquiry

²⁾ The cleanliness classes specified for components must be adhered to in hydraulic systems. Effective filtration prevents malfunction and, at the same time, increases the service life of components.

For the selection of filters, see data sheets RE 50070, RE 50076, RE 50081, RE 50086 and RE 50088.

Selection table

The material number can be established after the selection of the pump type and size and the pump pressure.

The material number includes all the components listed in the circuit diagram. The selection of the tank size depends on the size of the pump-motor group.

Tank size "A": 160; 250 litres ¹⁾

Pump size	$q_{V \max}$ in L/min	p_{\max} in bar	Power P in kW	El. motor frame size	Cooling power in kW	Material number
A10VSO 18	26	200	11	160 M	4	R901005244
A10VSO 28	39	135	11	160 M		R901005245
		190	15	160 L		R901005246

Tank size "B": 250; 400 litres ¹⁾

Pump size	$q_{V \max}$ in L/min	p_{\max} in bar	Power P in kW	El. motor frame size	Cooling power in kW	Material number
A10VSO 28	39	230	18.5	180 M	7,5	R901005247
		280	22	180 L		R901005248
A10VSO 45	63	115	15	160 L		R901005249
		145	18.5	180 M		R901005250
		170	22	180 L		R901005251
A10VSO 71	100	235	30	200 L	15	R901005252
		90	18.5	180 M	7,5	R901005253
		110	22	180 L		R901005254
		150	30	200 L	15	R901005255

Tank size "C": 400; 630; 800 litres ¹⁾

Pump size	$q_{V \max}$ in L/min	p_{\max} in bar	Power P in kW	El. motor frame size	Cooling power in kW	Material number
A10VSO 71	100	185	37	225 S	15	R901005256
		225	45	225 M		R901005257
A10VSO 100	145	100	30	200 L		R901005258
		125	37	225 S		R901005259
		160	45	225 M		R901005260

Tank size "D": 800; 1000 litres ¹⁾

Pump size	$q_{V \max}$ in L/min	p_{\max} in bar	Power P in kW	El. motor frame size	Cooling power in kW	Material number
A10VSO 100	145	195	55	250 M	30	R901005261
		265	75	280 S		R901005262
A10VSO 140	203	110	45	225 M	15	R901005263
		140	55	250 M	30	R901005264
		190	75	280 S		R901005265
		220	90	280 M		R901005266

¹⁾ The individual fill levels are marked on the oil level indicator

Attachment of components

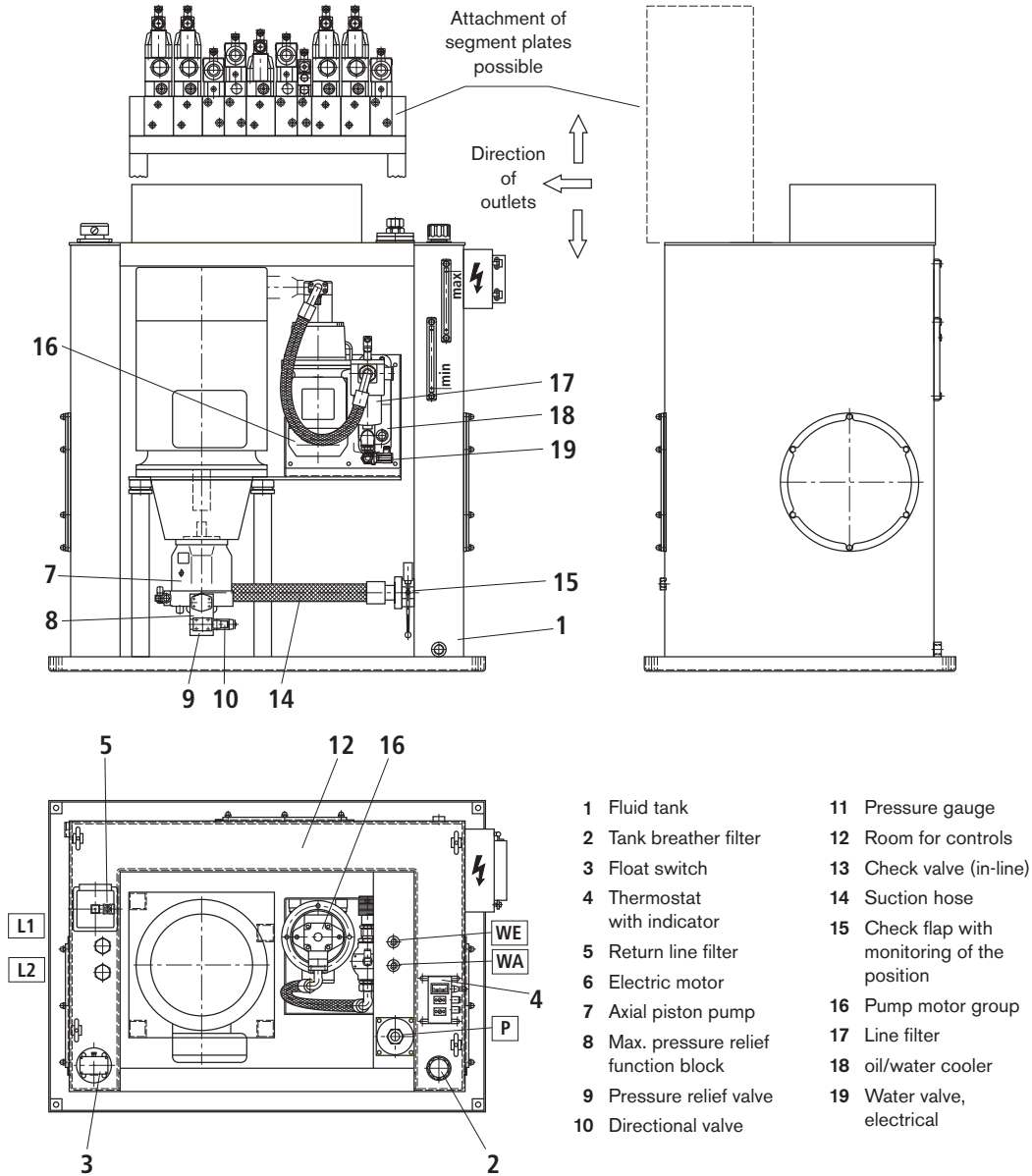

Connection sizes for flanges and fittings (SAE connections 3000 PSI) (in mm)

Pump type; size																				
A10VSO 18			A10VSO 28			A10VSO 45			A10VSO 71			A10VSO 100			A10VSO 140					
P	T	L	P	T	L	P	T	L	P	T	L	P	T	L	P	T	L			
Ø16	G1	Ø18	Ø20	G1	Ø18	Ø25	G1 1/2	Ø18				Ø30	G1 1/2	Ø22	Ø38	SAE2	Ø28			
																		Ø38	SAE2	Ø28

Typical noise data (measured at $n = 1450 \text{ min}^{-1}$, $\vartheta_{\text{oil}} = 50 \text{ }^\circ\text{C}$) Details in dB(A)

Pump type	Pressure in bar	Flow L/min	Pump size					
			18	28	45	71	100	140
A10VSO	100	$q_{V\text{min}}$	60	60	62	65	68	69
		$q_{V\text{max}}$	63	63	65	68	70	71
	200	$q_{V\text{min}}$	63	63	65	68	71	72
		$q_{V\text{max}}$	65	65	68	71	73	75
	300	$q_{V\text{min}}$	66	66	69	71	72	73
		$q_{V\text{max}}$	68	68	71	73	75	75

Noise pressure level to DIN 45635 part 1, 41;

Distance between microphone and power unit: -1m

Measured at $n = 1450 \text{ min}^{-1}$; operating temperature $\vartheta = 50 \text{ }^\circ\text{C}$

Hydraulic fluid: Mineral oil HLP to DIN 51524 part 2

Sound reflections at the place of installation can lead to a higher noise pressure level (lower noise pressure levels on enquiry).

At $n = 1000 \text{ min}^{-1}$ the noise data can be reduced by approx. 3 dB(A).

At $n = 1800 \text{ min}^{-1}$ the noise data can be assumed to be + 3 dB(A).

When an oil drip tray is used in accordance with the Water Resources Act, the typical noise values are about + 3 dB(A). Attached controls increase the noise pressure level!

Spare filter elements – DIN

Tank size	Pump type	El. motor P in kW	Filter element type for hydraulic system	Material no.	Filter element type for filter/cooler circuit	Material no.
A	A10VSO 18	7.5	ABZFE-R0063-10-1X/M-DIN	R901025291	ABZFE-N0063-10-1X/M-DIN	R901025361
	A10VSO 28	11; 15		R901025293		
B	A10VSO 28	18.5; 22	ABZFE-R0160-10-1X/M-DIN	R901025295	ABZFE-N0100-10-1X/M-DIN	R901025362
	A10VSO 45	15 - 22			ABZFE-N0160-10-1X/M-DIN	
	A10VSO 71	18.5 - 22	ABZFE-R0250-10-1X/M-DIN	R901025297	ABZFE-N0100-10-1X/M-DIN	R901025362
		30			ABZFE-N0160-10-1X/M-DIN	
C	A10VSO 71	37 - 45	ABZFE-R0400-10-1X/M-DIN	R901025298		
	A10VSO 100	30 - 45				
D	A10VSO 100	55 - 75				
	A10VSO 140	45				
		55 - 90				

Float switch settings

Size	Tank size		Residual capacity at upper switching point in litres	Capacity fluctuation in litres
	Size	Tank capacity in litres		
A		160	132	43
		250	218	43
B		250	195	49
		400	350	49
C		400	356	58
		630	560	70
		800	730	70
D		800	749	79
		1000	950	79

Unit dimensions (in mm)

Tank size "A"

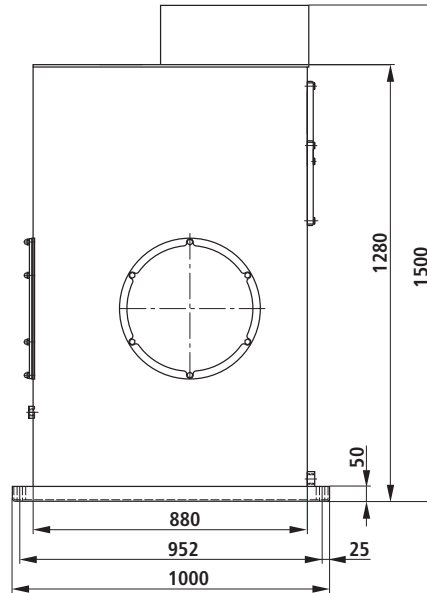
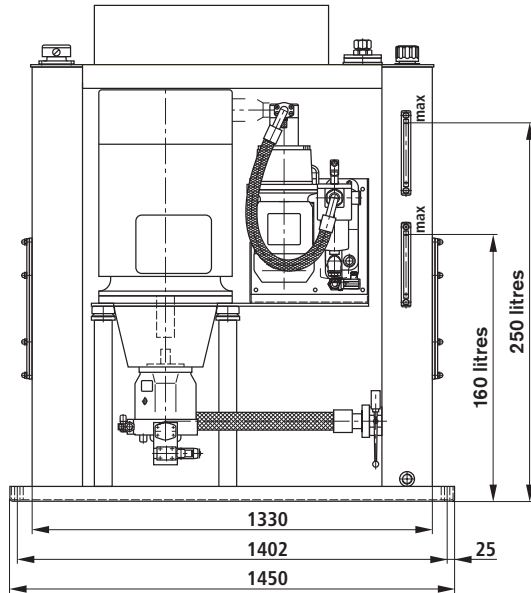

Tank size "B"

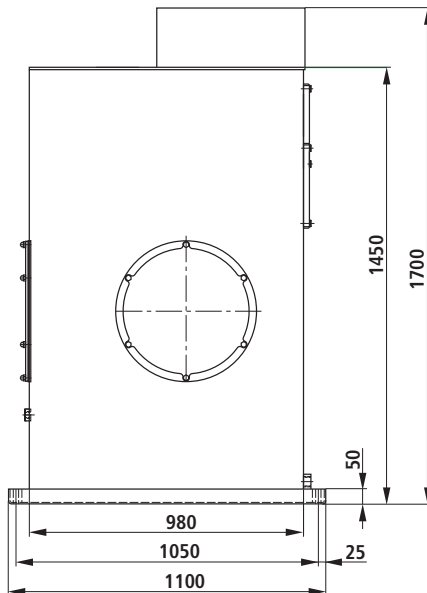
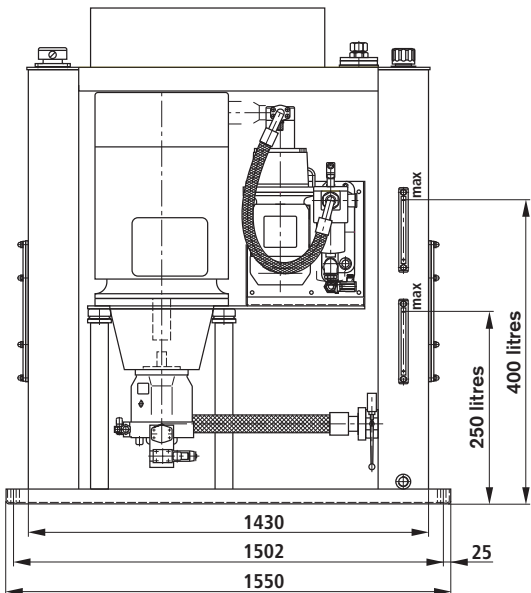

Unit dimensions (in mm)

Tank size "C"

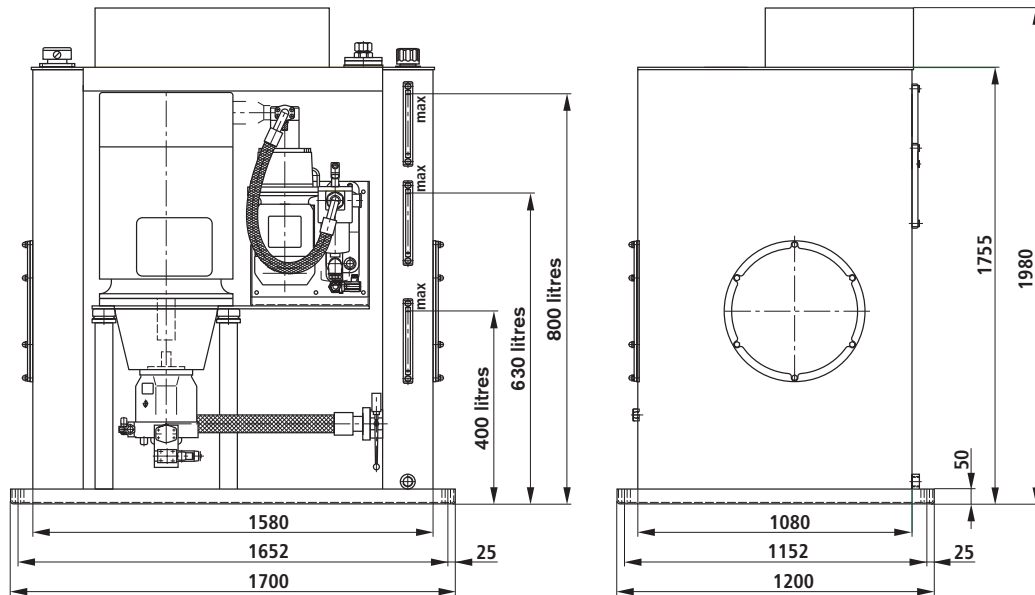

Tank size "D"

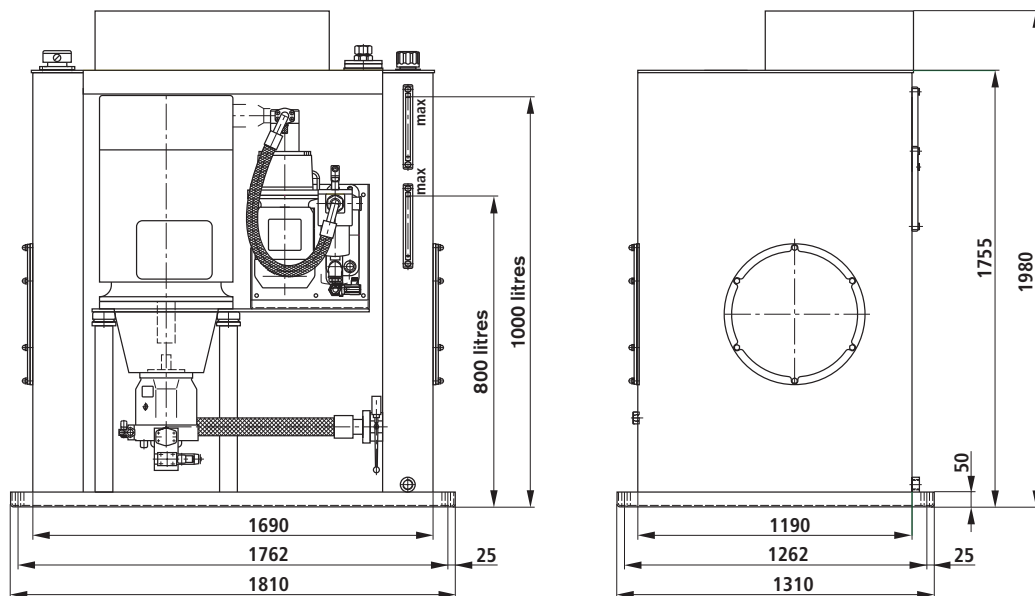

Option: Oil drip tray in accordance with the Water Resources Act (in mm)

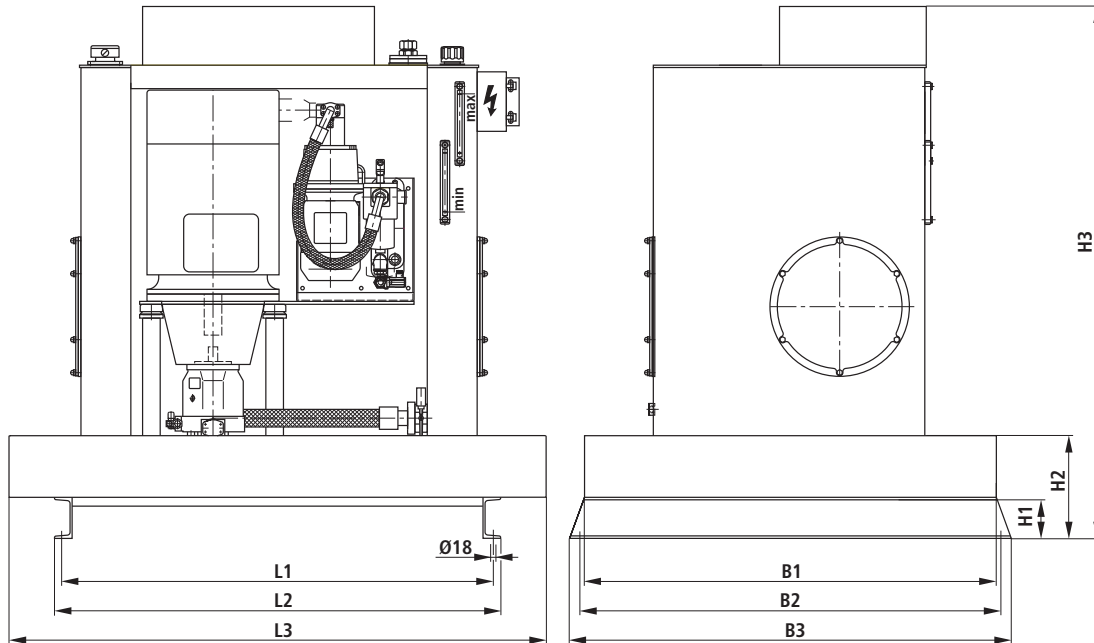

Tank size	Oil drip tray Material no.	L1	L2	L3	B1	B2	B3	H1	H2	H3
A	R901005589	1365	1420	2030	1580	1630	1680	160	295	1795
B	R901005592	1465	1520	2130	1680	1730	1780	160	335	2035
C	R901005593	1630	1685	2280	1780	1830	1880	160	415	2305
D	R901005595	1750	1805	2390	1890	1900	1950	180	475	2455

When an oil drip tray according to the Water Resources Act is used, the assumed typical noise pressure level amounts to + 3 dB(A).

Order example:

OELWANNE ABFAG-V-A-2030X1680X295
(Material no. R901005589)

Engineering notes

The assembly is designed according to the modular principle. For further information, please contact your Bosch Rexroth Sales Partner.

Comprehensive notes and suggestions can be found in The Hydraulic Trainer Volume 3, RE 00281, "Design of hydraulic systems."

Commissioning notes

General

- Power units supplied by us have been tested for function and performance. Changes and modifications of any kind are not permitted, otherwise the warranty will become void.
- Repairs may only be carried out by the manufacturer or his authorised dealers and subsidiaries. We will not assume any warranty for repairs carried out by customers.

Commissioning

- Always fill the hydraulic fluid in through a filter with the required minimum retention rate.
- Observe the arrow for direction of rotation when connecting the electric motor.
- Start up the pump under no-load conditions and let it displace at zero pressure for some seconds in order to provide sufficient lubrication.
- In no case may the pump be operated **without** oil.
- Should the pump not displace oil without bubbles after approx. 20 seconds, re-check the system.
- After the system has reached operating values, check the pipe connections for freedom from leakage. Check the operating temperature.

Bleeding

- Prior to initial commissioning the pump case must be filled with oil.

⚠ Important notes

- Installation, maintenance and repairs of the power units may only be carried out by authorised, trained and instructed personnel!
- The power units may only be operated within the permissible limits!
- When carrying out any work on the power unit, depressurise the system!
Unauthorised changes and modifications that affect the safety and function are not permitted!
- Provide protective equipment and do **not** remove any existing protective equipment and guards.
- Take care that all fixing screws are always tightened! (Observe prescribed tightening torque!)
- The generally valid safety regulations and regulations for the prevention of accidents must be adhered to!
- With tank size 100, fill in at least 130 litres (level indicator "max").

Note in the sense of the 98/37 EEC Machinery Directive, Annex II, Section B; manufacturer's declaration:

The assemblies delivered have been manufactured in accordance with the harmonised standards EN 982, EN 983, EN ISO 12100 and DIN EN 60204-1.

Commissioning is prohibited until it has been established that the machine into which the assemblies are to be installed comply with the stipulations of EC Directives.

Notes

© 2004 by Bosch Rexroth AG, Industrial Hydraulics, 97813 Lohr am Main
All rights reserved. No part of this document may be reproduced or stored, processed, duplicated or circulated using electronic systems, in any form or by any means, without the prior written authorisation of Bosch Rexroth AG. In the event of contravention of the above provisions, the contravening party is obliged to pay compensation.

The data specified above only serves to describe the product. No statements concerning a certain condition or suitability for a certain application can be derived from our information. The details stated do not release you from the responsibility for carrying out your own assessment and verification. It must be remembered that our products are subject to a natural process of wear and ageing.