

Electric Drives  
and Controls

Hydraulics

Linear Motion and  
Assembly Technologies

Pneumatics

Service

**Rexroth**  
Bosch Group

## VT-HACD-DPQ Digital Controller for electro-hydraulic Injection Molding Machines

RE 30146-B/09.13  
Replaces: 08.07

### Installation and Operation





## Contents

<b>1</b>	<b>General</b> .....	<b>5</b>
1.1	About this manual.....	5
	Additional Documentation .....	5
	Characters and Symbols .....	6
1.2	Scope of Supply .....	7
1.3	Requirements .....	7
<b>2</b>	<b>Installing the HACD-DPQ</b> .....	<b>8</b>
2.1	Safety Requirements .....	8
	Proper Use .....	9
	Personnel Selection and Qualifications .....	9
	Design Changes and Electrical Installation .....	9
2.2	Repair and Troubleshooting .....	10
2.3	Transport, Storage and Handling the Controller Card .....	11
2.4	Card Installation .....	12
2.5	Edge Connector Terminals and Pin Assignments .....	13
<b>3</b>	<b>Startup of the HACD-DPQ Controller Card</b> .....	<b>17</b>
3.1	Preparing for Use .....	17
3.2	Installing BODAC software .....	18
	Installation Requirements .....	18
	BODAC Setup .....	18
3.3	Initial startup with BODAC .....	19
<b>4</b>	<b>HACD-DPQ Operation</b> .....	<b>20</b>
4.1	Display/Input Keys and Connectors on the Front Panel .....	20

4.2	Diagnostics Test Jacks .....	21
4.3	Menu Tree for Setup and Parameters.....	21
4.4	Display/Input Key Operations .....	26
<b>5</b>	<b>Diagnostics .....</b>	<b>30</b>
5.1	Diagnostic Options on the HACD-DPQ Controller Card.....	30
5.2	Diagnostics Using BODAC .....	31
<b>6</b>	<b>Detecting Errors .....</b>	<b>32</b>
6.1	Error messages .....	32
6.2	Changing fuses .....	33
<b>7</b>	<b>Index.....</b>	<b>35</b>

## 1 General

### 1.1 About this manual

Before installing or operating your HACD-DPQ Controller card for the first time, you should read this Manual. Please note the safety requirements described in section 2.1.

Persons involved with the start-up and operation of the controller card should have proper training on the installation and operation of this type of equipment.

This manual is intended to inform you about the functions of this controller card and its intended use.

The Manual contains important safety instructions on proper installation and operation of the controller card. Observing these instructions will help you:

- avoid hazards and dangers
- minimize repair costs and downtime
- increase the useful life and reliability of the controller card

Additionally, please observe all regulations that are in effect in the country and/or community to prevent accidents and to protect the environment.

This manual only describes the installation and operation of the controller card. Information about starting up the controller card using BODAC software is located in a separate document: "Operation of the BODAC Software and Starting up the HACD-DPQ Control Card". A list of documentation for the HACD-DPQ can be found in the "Additional Documentation" section.

#### Additional Documentation

Included with this manual is the document "HACD-DPQ Digital Controller for Hydraulic Clamp Units".

It contains:

- RE sheet "RE 30 146" in paper form.
- Document RE 30 146-B: "Installation and Operation " (the document you read, included with the shipment).
- Document RE 30 146-01-B as online help (part of the BODAC package)
- Document RE 30 146-02-Z as online help for description of the CANopen interface (part of the BODAC package)
- Internet: <http://www.boschrexroth.com/HACD>

## 1 General

### Characters and Symbols

The following characters and symbols are used in the manual:

- Action symbol: The text following this symbol describes actions. These should be performed, from top to bottom, in the given order.
- ✓ Result symbol: The text following this symbol describes the results of an action.



Following this symbol you will find notes and useful tips for optimal use of the controller card..

#### Warning symbols

Special safety notes are provided at the relevant locations. These are indicated by the following symbols.



#### General hazard potential

Indicates a potentially hazardous condition which, if not avoided, could result in death or serious injury

If the hazard source can be specifically indicated, the corresponding pictogram will be used.



#### Electrical current hazard

This symbol refers to a hazardous condition caused by electrical current which, if not avoided, could result in death or serious injury.



#### Equipment damage

This symbol pertains to actions which could result in damage to equipment.

## 1.2 Scope of Supply

The equipment is packed in anti-static packaging to protect the controller card from electrostatic discharge. Observe instructions on the top side of the packaging.

Included in the shipment:

- Controller Card HACD-DPQ
- RE sheet RE 30 146-B

## 1.3 Requirements

Mounting the controller card in a card holder

- VT 3002-2x/G64

described in datasheet RE 29 928.

The card holder should be used only inside a control cabinet, as there is no protection from accidental contact.

If no power is provided by the user, the following power supply is available as an option:

- VT-NE30

described in datasheet RE 29 929.

## 2 Installing the HACD-DPQ

# 2 Installing the HACD-DPQ

## 2.1 Safety Requirements

Operate the HACD-DPQ controller card only if it is not damaged and is in proper operating condition and is applied for its intended purpose. Observe all safety and hazard instructions in the included documentation.

When faults occur, which compromise safety and result in changes in operating conditions, shut down the controller card immediately and notify responsible personnel.

Fault free and safe running of the controller card assumes appropriate transport, storage and installation, as well as proper startup and operation.

The HACD-DPQ Control Card has been built using the latest technology, and in accordance with recognized safety standards. Nevertheless, operation may result in hazard to persons or property if:

- The HACD-DPQ Controller Card is not used properly.
- The HACD-DPQ Control Card is not installed, commissioned and operated by qualified persons.
- Changes or modifications are made to the HACD-DPQ controller card.
- Safety requirements and safety notes are not observed.
- The HACD-DPQ controller card is intended for industrial use.

The card must not be operated until it has been determined that the system in which the controller card is installed, meets all applicable standards and safety regulations for the application.

In European countries: EC Directive 89/392/EWG (Machine Directive)

Operation is permitted only when applicable EMC regulations for the application are met.

Adherence to limits defined by regulations and standards are the responsibility of the manufacturer of the system or machine.

In European countries: EC Directive 89/336/EWG (EMC Directive)

In the United States: National Electrical Code (NEC) and National Electrical Manufacturers Association (NEMA), as well as local standards should be observed. The operator is required to adhere to the above named standards at all times.

## Proper Use

The HACD-DPQ controller card is designed for controlling electrohydraulic injection machines.

Applications include:

- closed loop pressure control
- closed loop position control
- spool configuration

Proper use requires adherence to the manuals and supplementary documentation, and observing relevant safety and operating standards.

## Personnel Selection and Qualifications

**Operation and Startup** Operation and startup of the HACD-DPQ controller card requires specialized skills. Therefore this work should be performed only by properly trained individuals.

Only persons who are trained or properly instructed should start up and operate the HACD-DPQ controller card. Additionally the oversight of a qualified supervisor may be advised.

Personnel are considered qualified if they are familiar with the installation, startup and operation of the HACD-DPQ controller card, and with all the warning notes and safety regulations contained in the accompanying documentation.

**Work on the electrical equipment must be performed only by qualified specialists or by personnel appropriately instructed and under the supervision and guidance of persons qualified and familiar with electrical safety standards.**

An electrical specialist is someone who, based on his technical knowledge and training, as well as knowledge of the relevant standards, is able to evaluate the tasks assigned to him, recognize potential hazards and take the appropriate safety measures.

**Repair and troubleshooting** Repair and troubleshooting requires specialized skills. Therefore, this work should be performed only by trained and designated specialists.

## Design Changes and Electrical Installation

User changes to the HACD-DPQ controller card may result in safety hazards.

Note the following recommendations on electrical installation:

- Use low-capacitance cables. Make cable connections without intermediate connections whenever possible.
- Control electronics should be isolated from electromagnetic noise sources (IE: V/F drives).
- Power wiring should not be routed in the vicinity of control electronics.
- Power wiring should not be routed in the vicinity of control wiring or cables.
- Route sensor lines separately.
- Maintain a distance of at least 1 meter from antenna lines, RF devices and radio equipment.

## 2 Installing the HACD-DPQ

- When using differential inputs switch both inputs on and off at the same time.
- When switching signal inputs, use dry circuit rated relays with gold-plated contacts (low voltages, low currents)
- Always shield all analog signal lines. Connect shields at the card end only, connecting to the "Shield" terminal, and leave the other end open to prevent ground loops.
- Connect to an appropriate system ground using stranded copper wire (min 2.5mm<sup>2</sup> / 12 AWG). The system ground is an essential component of the EMC protection for the controller card. The ground provides a path for noise that could otherwise enter the controller card through the signal and power supply lines. Noise is bypassed only if the system ground does not couple noise into the controller card. Bosch Rexroth also recommends shielding solenoid wiring.
- Do not use logical signals from the controller card (IE: "OK" signal) for switching machine safety circuits (see European Norm "Safety Requirements for Fluid Power Systems and Components" EN982:1996).
- If bus system is used, take care on the specific bus specifications:  
CANopen: CiA-301, CiA-302

## 2.2 Repair and Troubleshooting

If the control cabinet contains additional electrical components utilizing high voltage, always observe safety standards to prevent accidents! Use appropriate protective gear, such as safety shoes and safety gloves, when prudent!

Use appropriate tools (IE: insulated tools)

Before opening control cabinet doors, open the main disconnect.

To ensure safe working conditions, observe the following safety rules:

- Remove all power
- Ensure against unintended energization: lockout devices when possible, and use lockout warning tags
- Verify that voltage is not present
- Cover or close off adjacent areas that are still energized.

If work on energized components is necessary, have a second person present as a safety backup to actuate an E-STOP switch or open the main disconnect, if necessary. Use insulated tools only.

## 2.3 Transport, Storage and Handling the Controller Card

The packaging contains notes on handling of the controller card. These must be strictly followed.

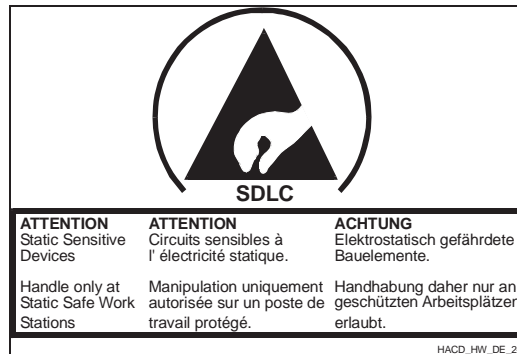

Fig. 1 Notes for handling printed on the packaging

Observe the following:

- Keep the controller card away from moisture and dust
- Observe the allowable storage temperature range of  $-20^{\circ}\text{C}$  to  $+70^{\circ}\text{C}$ . (allowable operating temperature:  $0 - 50^{\circ}\text{C}$ )



**NOTE!**

**Electrostatic discharge (ESD) can damage components on the controller card. To prevent damage, observe the following recommendations.**

Discharge static voltage from your body using accepted practices.

Work in a safe environment. Do not use any devices in the working environment that generate or hold static charge. Avoid working with the controller card in areas where floors or work surfaces is composed of materials that can generate a static charge.

Handle the controller card carefully. Do not touch any exposed pins or electronic components.

Transport and store the control card in its original packaging.

## 2 Installing the HACD-DPQ

### 2.4 Card Installation

Remove the card from its packaging only at a protected work place.

Do not touch any electrical components when placing the controller card in its proper card holder as shown in Fig. 2.

#### Correctly installing the HACD-DPQ controller card:

- Remove power from the rack when installing the card.
- Hold the card by the front panel and remove it from the packaging.
- Slide the card into the guide rails of the rack without using excessive force, as shown in Fig. 2 Installing the controller card.
- Snap the edge connector in place by gently pressing on the front panel.

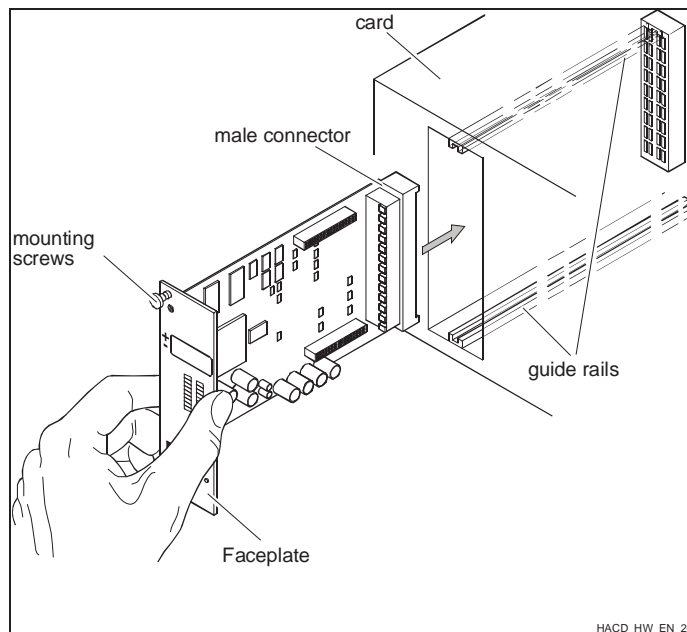

Fig. 2 Installing the controller card

- Tighten the two mounting screws on the front panel.
- ✓ The card is now installed correctly.

## 2.5 Edge Connector Terminals and Pin Assignments

The edge connector is a 64-pin, Type G (DIN 41612).

The pin assignments for the edge connectors are not fully downward compatible with older amplifier products.

Pin assignment tables:

Pin	Description	Type
2	DI 1 Back Pressure	Discrete input
4	DI 2 AUTO	Discrete input
6	DI 3 Force Transfer	Discrete input
8	DI 4 Inject/Jog +	Discrete input
10	DI 5 Incremental Home	Discrete input
12	DI 6 Post Decom/Jog -	Discrete input
14	DI 7 Analog Inject	Discrete input
16	DI 8 Analog Passthrough	Discrete input
18	Enable	Discrete input
20	DO 1 Velocity Profile act	Discrete output
22	OK <sup>2)</sup>	Discrete output
24	nc <sup>1)</sup>	
26	DO 2 Signal Fault	Discrete output
28	nc <sup>1)</sup>	
30	Valve Output 1	Analog output
32	Valve Output 2 or pressure feedback or position feedback	Analog output

Tab. 1 Pin assignment of edge connector Row d

<sup>1)</sup> = Pin not used in the basic version, but intended for later expansions. Do not connect to these pins.

<sup>2)</sup> = Signals indicates ready status of the controller card.

## 2 Installing the HACD-DPQ

Pin	Description	Type
2	Cavity Pressure +	Analog input
4	Cavity Pressure -	Analog input
6	Pressure FB #1 +	Analog input
8	Pressure FB #1-	Analog input
10	Pressure Command +	Analog input
12	Pressure Command -	Analog input
14	Pressure FB #2+	Analog input
16	Pressure FB #2 -	Analog input
18	Analog Cyl Pos Fdbk +	Analog input
20	Analog Cyl Pos Fdbk -	Analog input
22	Velocity Command +	Analog input
24	Velocity Command -	Analog input
26	Valve Output 3 or pressure feedback or position feedback	Analog Output
28	AGND	Analog GND
30	REF-	Reference voltage -10V
32	REF+	Reference voltage +10V

Tab. 2 Pin assignment of edge connector Row b

Row z	Pin	Description	Type
	2	nc <sup>1)</sup>	
	4	nc <sup>1)</sup>	
	6	nc <sup>1)</sup>	
	8	nc <sup>1)</sup>	
	10	Shield	Shield
	12	nc <sup>1)</sup>	
	14	nc <sup>1)</sup>	
	16	nc <sup>1)</sup>	
	18	nc <sup>1)</sup>	
	20	Ground	System ground
	22	DO 3 Back Pressure	Discrete output
	24	DO 4 Inject Forward	Discrete output
	26	DO 5 Decom Achieved	Discrete output
	28	DO 6 At Shot Size	Discrete output
	30	U <sub>B</sub>	Supply voltage
	32	LO	Supply GND

Tab. 3 Pin assignment of edge connector Row z

<sup>1)</sup> = Pins not used in the basic version, but intended for later expansions. Do not connect to these pins.

## 2 Installing the HACD-DPQ

Row f	Pin	Description	Type
	2	DO 7 At Pressure	Discrete output
	4	Clk +	Clock output SSI encoder
	6	Clk -	Clock output SSI encoder
	8	Data +	Data input SSI encoder
		UA1	Incremental encoder input
	10	Data -	Data input SSI encoder
		/UA1	Incremental encoder input
	12	UA2	Incremental encoder input
	14	/UA2	Incremental encoder input
	16	UA0	Incremental encoder input
	18	/UA0	Incremental encoder input
	20	nc <sup>1)</sup>	
	22	nc <sup>1)</sup>	
	24	nc <sup>1)</sup>	
	26	nc <sup>1)</sup>	
	28	CAN Gnd	CAN Bus reference
	30	CANL	CAN Bus In-/Output
	32	CANH	CAN Bus In-/Output

Tab. 4 Pin assignment of edge connector Row f

<sup>1)</sup> = Pins not used in the basic version, but intended for later expansions. Do not connect to these pins.

## 3 Startup of the HACD-DPQ Controller Card

### 3.1 Preparing for Use

The startup procedure for the HACD-DPQ controller card depends on a variety of factors that are determined by the individual application. For this reason, only the basic startup steps are described in this manual.

#### Preparing the controller card for use:

- Carefully check cabling.
- Apply power to the HACD-DPQ controller card.

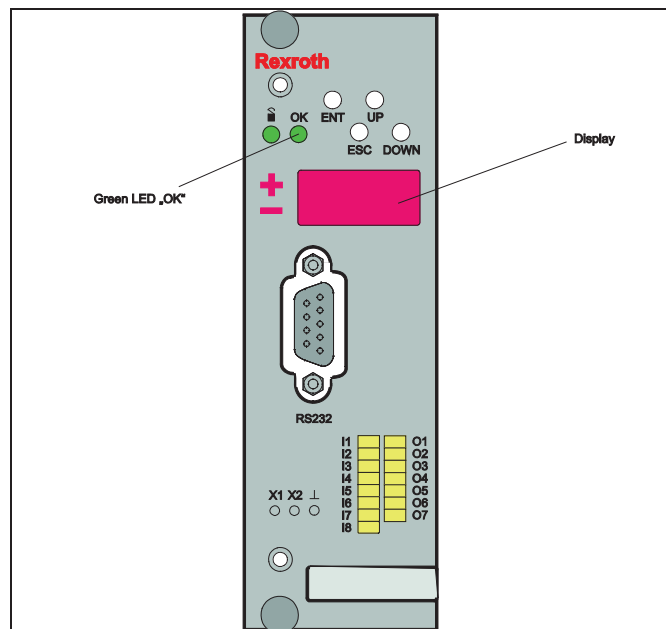

Fig. 3 Front panel of the HACD-DPQ Controller Card

- ✓ The controller card performs an internal function test.
- ✓ The display on the controller card shows the manufacturer name and version number in scrolling text (when powered up)

### 3 Startup of the HACD-DPQ Controller Card

## 3.2 Installing BODAC software

BODAC software (ordering code SYS-HACD-BODAC-01 ordering number R900777335) can download via Internet ([www.boschrexroth.com/hacd](http://www.boschrexroth.com/hacd)). This software is used for initial startup and as a convenient configuration and monitoring tool for the controller card. BODAC can be used to configure the settings and parameters for optimal operation of the HACD-DPQ controller card. The connected HACD-DPQ card configures the function, menus and program windows in BODAC. This makes using the software easy.

### Installation Requirements

**Hardware** 100% IBM compatible PC with the following minimum requirements:

- 200 MHz Pentium processor (or equivalent)
- 32 MB working memory (RAM)
- VGA graphics card, minimum resolution: 800x600 pixels
- Hard drive with minimum 2 MB available space
- CD-ROM drive
- Mouse
- Available serial port or USB/RS232 converter (S/N R901066684)

**Software** ■ Operating system: Windows 2000 / XP.

If the hardware/software requirements are met, you can install BODAC as described in the next section.

### BODAC Setup

To start the installation of BODAC, execute the "Setup.exe" file.

#### Installing BODAC software:

- Insert the CD-ROM and locate the file "Setup.exe".
- Double-click on "Setup.exe".
- ✓ The setup program will load and display a start screen.
- To run Setup, follow the instructions on the screen.
- ✓ BODAC software will then be installed.

### 3.3 Initial startup with BODAC

After installing the HACD-DPQ controller card in a rack, as described in section 2.4 "Card Installation", and all initial steps have been completed properly, the card startup is ready.

Before proceeding with the following steps, be sure that the following requirements have been met:

- Serial interface cable is available
- A serial port on the PC is available
- BODAC software is installed.

**Proceed with the initial startup:**

- Connect serial cable (ordering number R900776897) to the connector on the HACD-DPQ card.
- Plug serial cable into the serial port (COM) on the PC (or use USB-converter – S/N R90166684).
- ✓ The HACD-DPQ card and PC are now connected.
- Start the BODAC software.
- Perform the software-side startup as described in the "Start- up and Operation" document.

## 4 HACD-DPQ Operation

### 4.1 Display/Input Keys and Connectors on the Front Panel

You can use the display, input keys and connectors on the front panel of the HACD-DPQ to check parameters and settings, attach diagnostic instruments and connect the card to a PC.

The following illustration shows an overview of the display, input keys and connectors on the front panel.

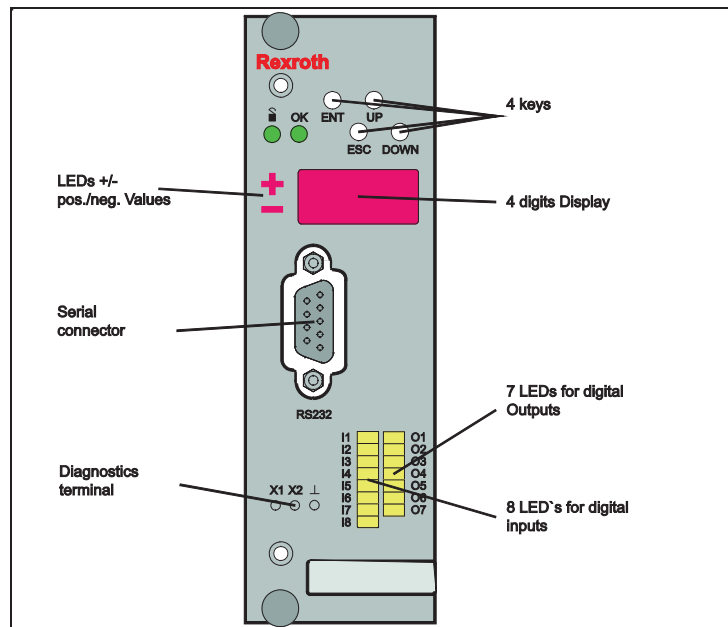

Fig. 4 Display, input keys and connectors on the control card

**Display** The display is four characters in length. Messages that exceed four characters are displayed as a scrolling display.

When parameters are displayed, the negative or positive sign is indicated by the "+" and "-" LEDs.

**LEDs for Discrete I/O** The input LEDs indicate the state of the discrete input signals. The output LEDs show the state of discrete outputs from the controller card. When a signal is present on a discrete I/O, the associated LED will illuminate.

**Serial port** The serial port on the front panel is configured as a standard RS-232 port using a 9-pin D-Sub female connector. A standard 9 pin serial data cable is used to connect the serial port to a PC.

**Buttons** Four buttons are located on the front panel of the card. The functions of these buttons are described in details in section 4.4 "Performing operations".

## 4.2 Diagnostics Test Jacks

The diagnostic test jacks on the front panel of the card can be used to connect external test instruments. Two analog voltage signals are available to perform measurements.

## 4.3 Menu Tree for Setup and Parameters

The following contains an overview of the menus that can be selected using the buttons on the HACD-DPQ controller card. Shown are the parameters and settings that are available.

An overview of the items listed below are shown on the following pages:

- Menu tree "Parameters Part 1"
- Menu tree "Parameters Part 2"
- Menu tree "Parameters Part 3"
- Menu tree "Parameters Part 4"
- Menu tree "Setup"

For a detailed description of the settings and parameters, please refer to document: "Starting up the HACD-DPQ Control Card and Operation of BODAC Software".

4 HACD-DPQ Operation

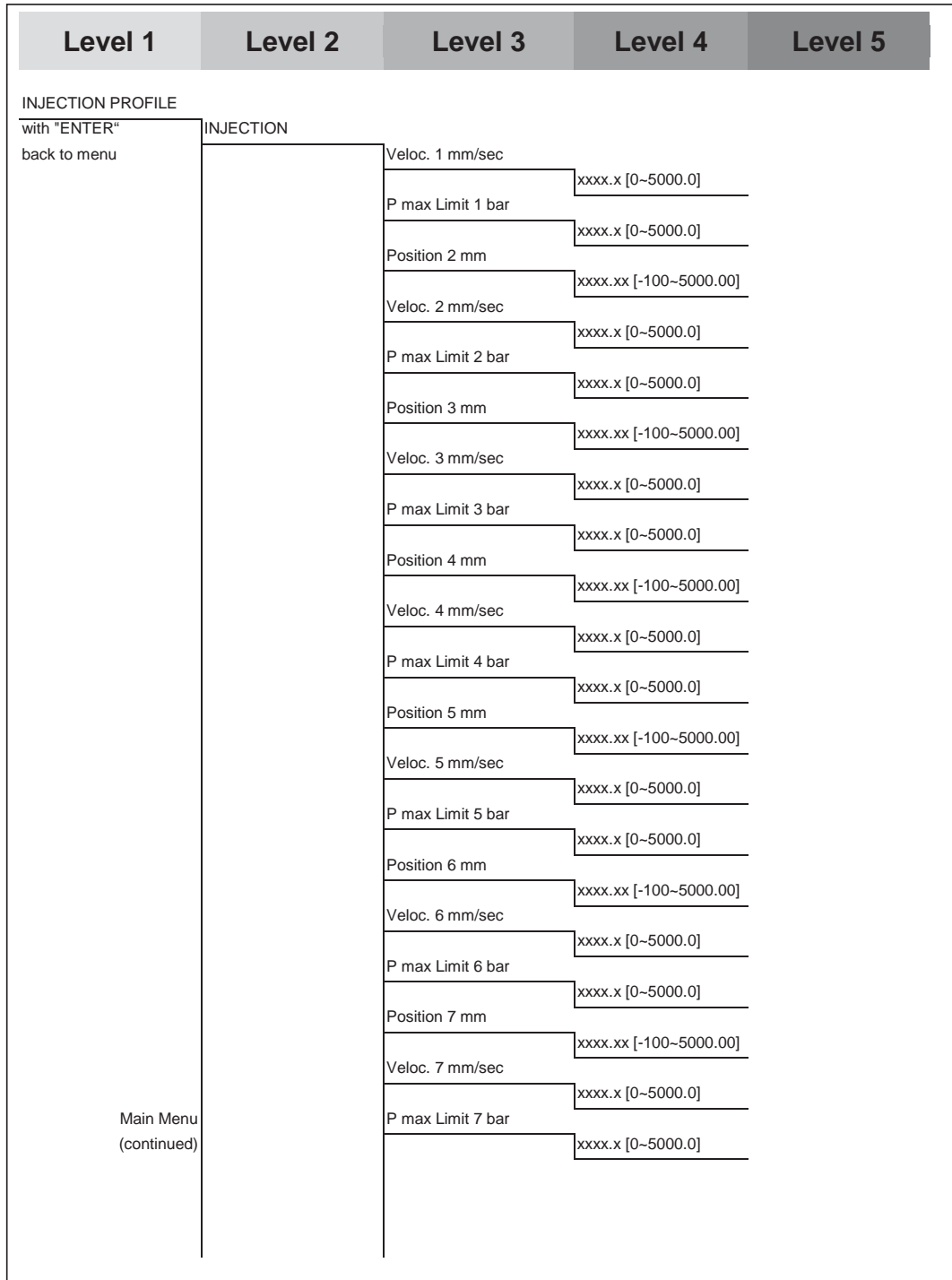

Fig. 5 Menu tree "Parameters Part 1"



4 HACD-DPQ Operation

Level 1	Level 2	Level 3	Level 4	Level 5	
Main Menu (continued)		Pressure 3 bar		xxxx.x [0-5000.0]	
		Time 3 sec		xxx.xx [0-999.99]	
		Veloc. Limit 3 %		xxx.xx [0-999.99]	
		Pressure 4 bar		xxx.xx [0-5000.0]	
		Time 4 sec		xxx.xx [0-999.99]	
		Veloc. Limit 4 %		xxx.xx [0-999.99]	
		Pressure 5 bar		xxx.xx [0-5000.0]	
		Time 5 sec		xxx.xx [0-999.99]	
		Veloc. Limit 5 %		xxx.xx [0-999.99]	
		BACK PRESSURE			
			Pressure 2 bar		xxxx.x [0-5000.0]
			Screw Speed 2 %		xxx.xx [0-999.99]
			Position 3 mm		xxxx.x [0-5000.0]
			Pressure 3 bar		xxxx.x [0-5000.0]
		Screw Speed 3 %		xxx.xx [0-999.99]	
		Position 4 %		xxxx.x [0-5000.0]	
		Pressure 4 bar		xxxx.x [0-5000.0]	
		Screw Speed 4 %		xxx.xx [0-999.99]	
		Shot Size mm		xxx.xx [0-999.99]	
Main Menu (continued)				xxxx.x [0-5000.0]	

Fig. 7 Menu tree "Parameters Part 3"

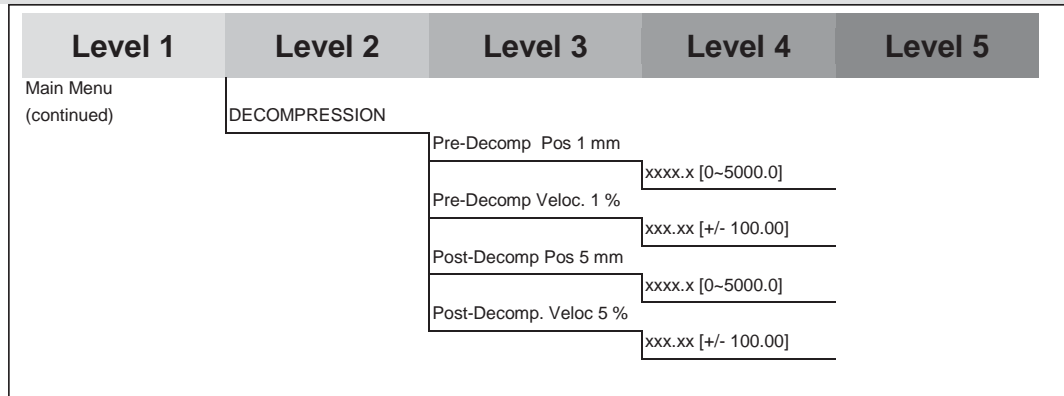

Fig. 8 Menu tree "Parameters Part 4"

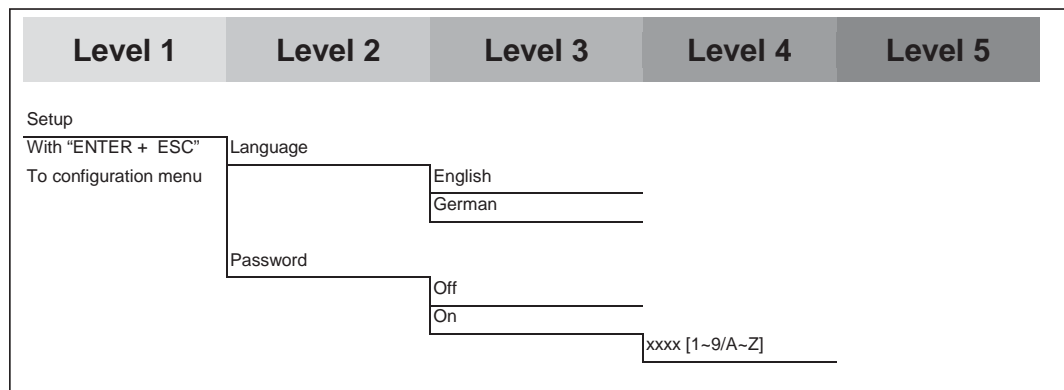

Fig. 9 Menu tree "Setup"

## 4.4 Display/Input Key Operations

All operations can be performed directly on the card using the "UP", "DOWN", "ENTER" and "ESCAPE" keys.



**The keys are especially useful for quickly and easily checking, changing or correcting parameters and settings.**

**Always use BODAC software for the initial startup before placing the card in service.**

Before making any changing to parameters or settings, familiarize yourself with the menu structure of the card. This can be found in section 4.3: "Menu tree for settings and parameters".

### Key functions:

**UP** Pressing the "UP" key moves in the upward direction, within the selected level, to available menu items. (for an overview, see section 4.3: "Menu tree for settings and parameters".)

**DOWN** Pressing the "DOWN" key moves in the downward direction, within the selected level, to available menu items. (for an overview, see chapter 4.3 „Menu Tree for Setup and Parameters“.

**ENTER** Change menu mode:

Press the "ENTER" key for 2 seconds or longer, to switch to configuration mode – "EDIT Parameters".

Change menu level:

Press the "ENTER" key to take you one level lower in the menu structure, or confirms an entered value.

**Note: The entered value is stored immediately in memory!**

**ESCAPE** Pressing the "ESCAPE" key takes you one level higher in the menu structure.

●  
ENTER

+

●  
ESCAPE

Pressing the "ENTER" and "ESCAPE" keys simultaneously opens the configuration menu.

The configuration menu is structured in levels. The first level contains main categories, below which are additional subcategories and setting. Depending on the entry selected, a main category may have up to 4 sub-levels.

The following figure illustrates the menu level structure:

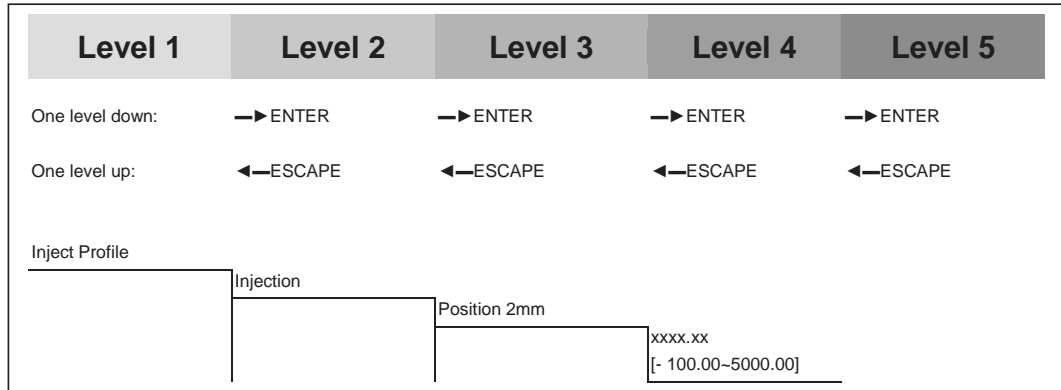

Fig. 10 Example of menu levels in the configuration mode

#### Changing from Run Mode to Configuration Mode – “EDIT Parameters”:

Precondition:

The card must be in run mode.

The display will show scrolling text to display the manufacturer’s name, the software version for the controller, or a custom configured text string.

- Press and hold “Enter” for at least 2 seconds until the display reads “INJECT PROFILE”.
- ✓ The controller card is now in "EDIT Parameter" mode.

#### Changing from Run Mode to Configuration Mode:

Precondition:

The card must be in run mode.

- The display will show scrolling text to display the manufacturer’s name, the software version for the controller, or a custom configured text string.
- Press and hold "ENTER" and "ESCAPE" simultaneously for at least 2 seconds (except when in “EDIT Parameter” mode, see above) until the display reads “Set-up”.
- ✓ The controller card is now in the configuration mode.

## 4 HACD-DPQ Operation

### To exit Configuration Mode:

As an example, the second level of the "Setup" menu is shown.

The display of the controller card shows the option "Sprache/Language".

- Press "ESCAPE".
- ✓ The display is scrolling "Setup".
- Press "Escape".
- ✓ The display will show scrolling text to display the manufacturer's name, the software version for the controller, or a custom configured text string.
- ✓ The display shows the manufacturer's name and the version number of the controller card or your individual text as running text.
- ✓ You are now in the operation mode.



**If while in Configuration Mode no entry is made within one minute, the controller card will automatically return to successively higher menu levels until Run Mode is reached.**

**The HACD-DPQ Control Card is fully operational in Configuration Mode.**

### To change a parameter using the input keys:

As an example, the parameter "TRANSFER BY Hydraulic Pos mm" is shown. In this case, set the parameter to "10". The card is now in Run Mode.

The display will show scrolling text to display the manufacturer's name, the software version for the controller, or a custom configured text string.



#### Warning!

When changing parameters using the input keys, hardware inputs are configured even when the discrete input „Enable“ is active.

**Do not change** any analog input from voltage to current or current to voltage when active. Changing the analog inputs configuration may result in incorrectly interpreted values.

**This can result in uncontrolled system operation and damage to the machine!**

- Press and hold the "ENTER" key until the display reads "INJECT PROFILE".
- ✓ The card is now in the configuration mode.
- Press the "ENTER" key to select "INJECT PROFILE".
- ✓ The controller card is now at the second level of the configuration menu "INJECT PROFILE".
- Press the "UP" or "DOWN" keys to select "TRANSFER BY".
- Press "ENTER".

- ✓ The menu entry "Hydraulic Pos. mm" is shown.
- Press "ENTER".
- Press the the "UP" or "DOWN" keys to select "Hydraulic Pos mm".
- Press "ENTER".
- ✓ The current value is shown.
- Press "UP".

This creates a positive sign. Pressing "DOWN" gives the value a negative sign.

- Press the "UP" until "1" is displayed.
- Press the "ENTER".
- Press the "UP" until "1" is displayed.
- Press the "ENTER".
- Press the "UP" until "." is displayed.
- Press the "ENTER".
- Press the "UP" until "0" is displayed.
- Press the "ENTER".
- Press the "UP" until "0" is displayed.
- Press the "ENTER".
- ✓ The parameter "TRANSFER BY Hydraulic Pos mm" 10 mm is now entered and displayed.
- Exit the Configuration menu by pressing the "ENTER" five times.

## 5 Diagnostics

### 5.1 Diagnostic Options on the HACD-DPQ Controller Card

#### Diagnostics terminal



The diagnostic test jacks on the front panel of the HACD-DPQ controller card (see section 4.1 Display/Input Keys and Connectors on the Front Panel, Fig. 4 ) provide two analog outputs with the following ratings:

- X1, 10 Volts for test equipment having  $R_i < 100 \text{ k}\Omega$  )
- X2, 10 Volts for test equipment having  $R_i < 100 \text{ k}\Omega$ )
- COM, ground

#### Test jack "X1"

On test jack "X1" there are several signals available from where you can choose. The signal is selected in BODAC.

#### Test jack "X2"

Using the Testjack menu in BODAC, the signal to be measured can be selected.

#### Display indication when an error occurs

During initial startup, BODAC software can be used to select the action of the controller when an error occurs (available in the "Error" screen). If the controller card detects an error, which has been configured with BODAC software, the error will be displayed on the HACD-DPQ controller card.



If the control card detects an error configured with BODAC software, respond as follows:

**The display will flash "ERR" (Error) on the controller card!**

**Press "ENTER" to display the error message and clear the error.**

The procedure for selecting the action desired when an error occurs can be found in the document "Starting up the HACD-DPQ Control Card and Operation of the BODAC Software".

## 5.2 Diagnostics Using BODAC

The BODAC software includes additional detailed diagnostics capabilities.

The "Motion Data" screen and the "Status" screen display the current status of the controller card and of the connected sensors and devices.

**Motion Data Screen** The Motion Data screen displays the internal control signal values in the controller card. This provides a quick overview of the process status and values.

**Status Screen** The Status screen is used to display the status of the controller card. Each entry will display either "OK", "WARNING" or "ERROR" as a value.

For additional information on the Motion Data screen and the Status screen, refer to document "Starting up the HACD-DPQ Control Card and Operation of the BODAC Software".

## 6 Detecting Errors

# 6 Detecting Errors

## 6.1 Error messages

Error message	Description
+/- 10 V voltage	Reference voltage +10 V (b32) or reference voltage -10 V (b30) outside allowable tolerance.
24 V Power	Power supply $U_b$ (z30) less than $U_b$ min.
DO1–DO7 and ENABLE short circuit	Short circuit on one or more of the 8 discrete outputs.
Checksum Flash	Checksum error in program or data memory (Flash or EEPROM).
Memory error	Error in working memory (RAM).
Analog Input AI1 Pressure Command	The signal on analog input AI1 is outside the valid signal range (adjustable in Analog Config Screen in BODAC).
Analog Input AI2 Pressure FB#1	The signal on analog input AI2 is outside the valid signal range (adjustable in Analog Config Screen in BODAC).
Analog Input AI3 Cavity Pressure	The signal on analog input AI3 is outside the valid signal range (adjustable in Analog Config Screen in BODAC).
Analog Input AI4 Pressure FB#2	The signal on analog input AI4 is outside the valid signal range (adjustable in Analog Config Screen in BODAC).
Analog Input AI5 Analog Cyl Pos Fdbk	The signal on analog input AI5 is outside the valid signal range (adjustable in Analog Config Screen in BODAC).
Analog Input AI6 Velocity Command	The signal on analog input AI6 is outside the valid signal range (adjustable in Analog Config Screen in BODAC).
SSI	Cable fault or SSI encoder.
Max. Freq. Fault	Max. frequency for the incremental encoder is exceeded.
Encoder Channel A	Cable fault on the incremental encoder.
Encoder Channel B	Cable fault on the incremental encoder.
Bus fault	Profibus: The slave has left condition "DATA_EXCHANGE" CANopen: The mode has left the condition "OPERATIONAL" DeviceNet: The mode has left the condition "ONLINE".

## 6.2 Changing fuses

The controller card is protected against overload by means of a fuse. The fuse is the following type:

- F / 4A / 250V



### NOTE!

#### The fuse is defective and must be replaced!

The fuse has opened due to mechanical damage or a product defect.

In this case, replace the fuse with a new one of the type indicated above.

The fuse has opened due to external connections, IE: externally connected components or wiring connected to the controller card have faulted.

In such cases, diagnose and correct the problem that caused the fuse to open.

Only then replace the fuse with a new one.

## 6 Detecting Errors

### Replacing the fuse on the HACD-DPQ Control Card:

- Remove HACD-DPQ controller card the card holder (reverse of the procedure described in section 2.4 Card Installation)
- Gently remove the fuse from the fuse holder (see Fig. 11 Fuse on the HACD-DPQ Controller Card).

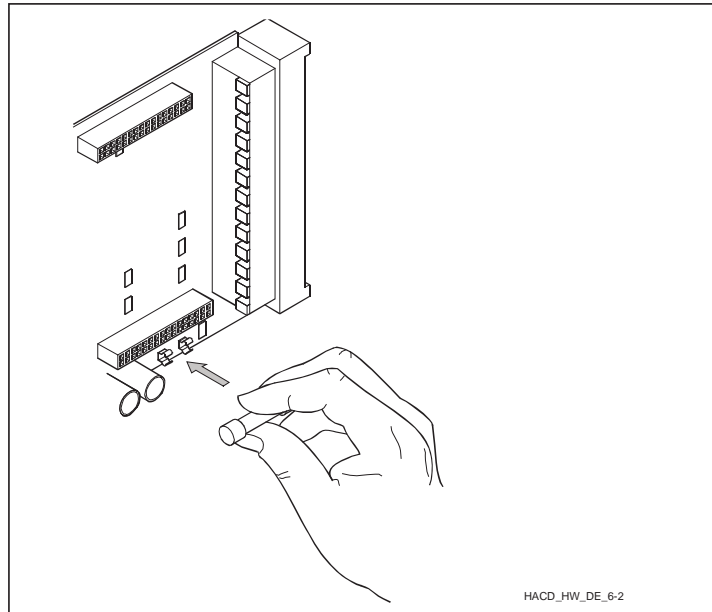

Fig. 11 Fuse on the HACD-DPQ Controller Card

- Use a suitable test device to check the fuse. (continuity test)
- If the fuse is defective, replace it with the same type.
- Reinstall the HACD-DPQ controller card and perform a functional test.

## 7 Index

Analog GND	14
Analog input	14
Change Parameter	28
Configuration mode	28
Diagnostics terminal	30
Drives	
Electromechanical and electrohydraulic	5
Menu tree	
Parameters Part 1	22
Parameters Part 2	23
Parameters Part 3	24
Parameters Part 4	25
Setup	25
Reference voltage	14
Setup	25
Sprache/Language	25
Supply GND	15
Supply voltage	15
Transport	11

**Rexroth**  
Bosch Group

© This document, as well as the data, specifications and other information set forth in it, are the exclusive property of Bosch Rexroth AG. It may not be reproduced or given to third parties without its consent.

The data specified above only serve to describe the product. No statements concerning a certain condition or suitability for a certain application can be derived from our information. The information given does not release the user from the obligation of own judgment and verification. It must be remembered that our products are subject to a natural process of wear and aging.

Printed in Germany  
RE 30146-B/09.13  
Replaces: 08.07