

4/3 proportional directional control valve, without position control, with on-board electronics (OBE)

RE 29051/01.06
Replaces: 09.05

1/18

Type 4WRBAE..E../..W..

Nominal size (NG) 6, 10
Unit series 2X
Maximum working pressure P, A, B 315 bar, T 250 bar
Nominal flow rate Q_{nom} 18...32 l/min (NG6), 35...65 l/min (NG10)

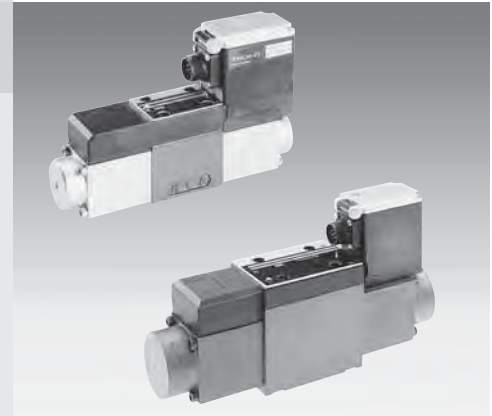

Overview of Contents

Contents	Page
Features	1
Ordering data	2
Preferred types	2
Symbols	2
Function, sectional diagram	3
Accessories	4
Technical data	5 to 7
On-board trigger electronics	8 to 11
Characteristic curves	12 to 15
Unit dimensions	16 and 17

Features

- Directly controlled NG6 and NG10 valves with positive overlap and on-board electronics
- Actuated on both sides, standard symbols E, W
- Adjustable by means of the setpoint in the on-board electronics, see Characteristic Curves
- Valves are preset at the factory, ramp is set to minimum ramp time and overlap (Q_{min} at 0.8 V) to Q_{nom} at 8 V
- For subplate attachment, mounting hole configuration NG6 to ISO 4401-03-02-0-94, NG10 to ISO 4401-05-04-0-94
- Subplates as per catalog sheet, RE 45053 for NG6, RE 45055 for NG10 (order separately)
- Plug-in connector to DIN 43563-AM6, see catalog sheet RE 08008 (order separately)
- Data for the on-board trigger electronics
 - Complies with CE, EMC directives EN 61000-6-2: 2002-08 and EN 61000-6-3: 2002-08
 - $U_B = 24 V_{nom}$ DC
 - Electrical connection 6P+PE
 - Signal actuation
 - Standard 0...±10 V (A1)
 - Version 2...12...20 mA (F1)
 - Valve curves calibrated at the factory

Function, sectional diagram

General

Directly operated type 4WRBAE 4/3 proportional directional control valves without position control, with on-board electronics, are available in nominal sizes 6 and 10. Hysteresis is < 6% for the NG6 and < 8% for the NG10. The valve electronics are integrated and are preset during valve testing. The operating limits are largely determined by the available magnetic force, see characteristic curves.

Basic principle

To adjust the oil flow rate, a setpoint is set in the valve electronics. Based on the polarity and magnitude of this setpoint, the electronics control the solenoid coil "a" or "b" with the appropriate amount of magnetic force. The proportional solenoid converts the current to a mechanical force, with which an armature plunger acts on a spool to push against the spring. If the magnetic force and the spring force are the same, this produces a spool position in conformity with the spring characteristic curve. If the drop in pressure is minimal (< 30 bar) the throttling function takes effect, if the pressure drop is greater, the operating limits (see characteristic curves) must be observed.

The pressure drop at the valve is reliably limited by the use of an external pressure compensator with shuttle valve.

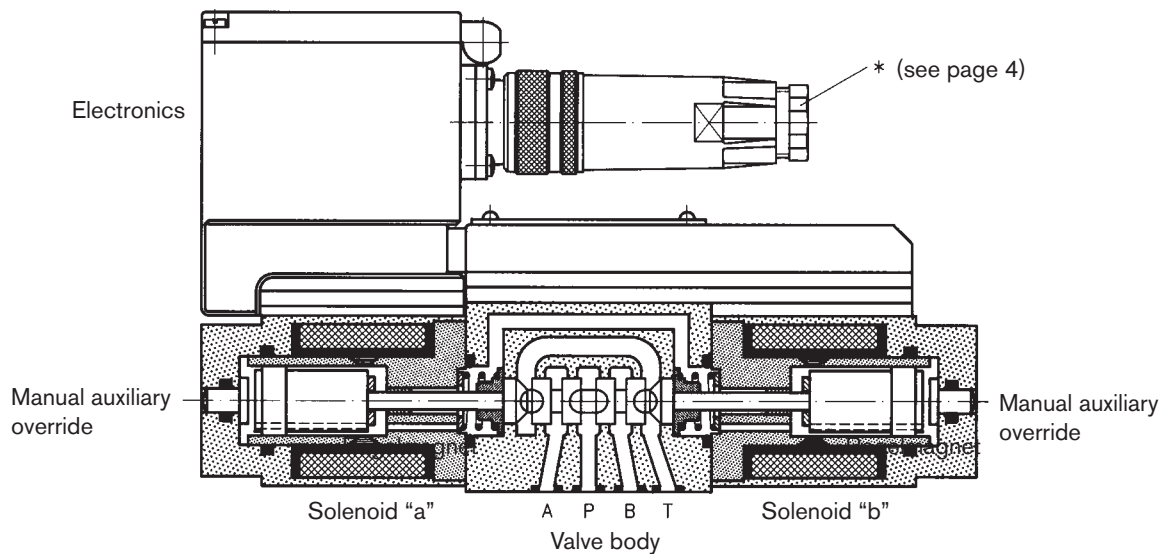

NG6

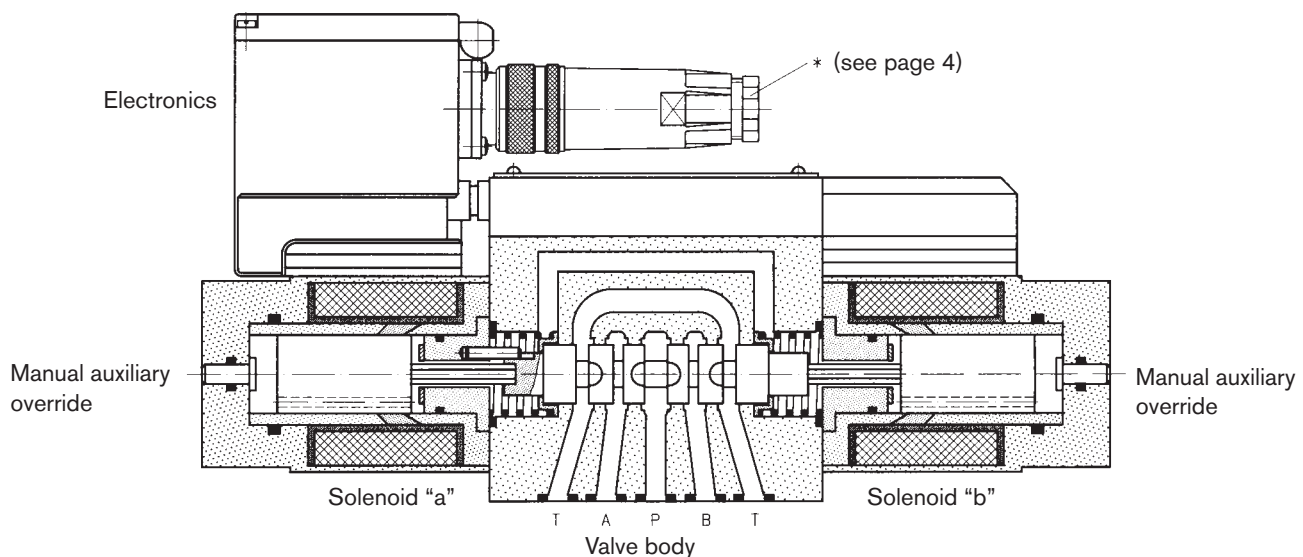

NG10



Accessories

Type		Material Number	
(4x)  ISO 4762-M5x30-10.9	Cheese-head bolts NG6	2 910 151 166	
(4x)  ISO 4762-M6x35-10.9	Cheese-head bolts NG10	2 910 151 207	
* 	Plug-in connector 6P+PE, see also RE 08008	KS	1 834 482 022
		KS	1 834 482 026
		MS	1 834 482 023
		MS	1 834 482 024
		KS 90°	1 834 484 252

Testing and service equipment

Test box type VT-PE-TB3, see RE 30065

Measuring adapter 6PE+PE type VT-PA-2, see RE 30068

Technical data



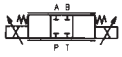
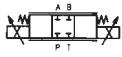
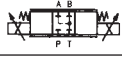
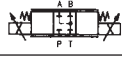

General

Construction	Spool-type valve	
Actuation	Proportional solenoid without position control, with on-board electronics OBE	
Connection type	Subplate, mounting hole configuration NG6 (ISO 4401-03-02-0-94), NG10 (ISO 4401-05-04-0-94)	
Mounting position	Optional	
Ambient temperature range	°C	-20...+50
Weight	NG6 kg	3.1
	NG10 kg	8.3
Vibration resistance, test condition	Max. 25 g, shaken in 3 dimensions (24 h)	

Hydraulic (measured with HLP 46, $\vartheta_{oil} = 40\text{ °C} \pm 5\text{ °C}$)

Pressure fluid	Hydraulic oil to DIN 51524...535, other fluids after prior consultation				
Viscosity range	recommended mm ² /s	20...100			
	max. permitted mm ² /s	10...800			
Pressure fluid temperature range	°C	-20...+70			
Maximum permitted degree of contamination of pressure fluid Purity class to ISO 4406 (c)	Class 18/16/13 ¹⁾				
Direction of flow, see symbol	NG6		NG10		
Nominal flow rate (at $\Delta p = 5\text{ bar}$)*	l/min	18	32 (per metering edge)	35	65 (per metering edge)
	Q_A at 8 V l/min	15 ± 1	26 ± 1	28 ± 2	58 ± 3
Leakage per metering edge ($\Delta p = 100\text{ bar}$)	cm ³ /min	 A → T = 80 B → T = 80	 A → T = 80 B → T = 80		
Leakage drain ($\Delta p = 5\text{ bar}$)	l/min	 A → T = 0.8...1.6 B → T = 0.8...1.6	 A → T = 0.4...0.8 B → T = 0.4...0.8		
Max. working pressure	bar	Port P, A, B: 315 Port T: 250			

Static/Dynamic

Hysteresis	%	≤ 6	≤ 8		
Response sensitivity	%	≤ 3	≤ 5		
Response time 100% signal change (ramp = T_{min})	ms	50 	100 	90 	130 

¹⁾ The purity classes stated for the components must be complied with in hydraulic systems. Effective filtration prevents problems and also extends the service life of components. For a selection of filters, see catalog sheets RE 50070, RE 50076 and RE 50081.

* Nominal flow

This is always based on a pressure differential of $\Delta p = 5\text{ bar}$ at the throttling point. Where other pressure differentials are involved, the flow is calculated according to the following formula:

$$Q_x = Q_{nom} \cdot \sqrt{\frac{\Delta p_x}{5}}$$

However, the **operating limits** must be borne in mind. If they are exceeded, the ensuing flow forces lead to uncontrollable spool movements. **Pressure compensators** are used to reliably limit Δp .

Technical data

Electrical, trigger electronics integrated in valve

		NG6	NG10
Cyclic duration factor	%	100	
Degree of protection		IP 65 to DIN 40050 and IEC 14434/5	
Connection		Plug-in connector 6P+PE, DIN 43563	
Supply voltage 24 V DC _{nom} Terminal A: B: 0 V		Battery voltage 10.2...31 V Rectified voltage 10.2...27 V Residual ripple max. 2 V _{ss}	
Power consumption		Solenoid \square 45 mm = 40 VA max.	Solenoid \square 60 mm = 60 VA max.
External fuse		2.5 A _F	
Input, "standard" version Terminal D: U _E E:	= A1	Differential amplifier, R _i = 100 kΩ 0...±10 V 0 V	
Input, "mA signal" version Terminal D: I _{D-E} E: I _{D-E}	= F1	Burden, R _{sh} = 200 Ω 4...12...20 mA Current loop I _{D-E} feedback	
Max. voltage to differential inputs over 0 V		D → B } D → B } max. 18 V DC	
Safety earth conductor		See pin assignment (installation in conformity with CE)	
Recommended cable		See pin assignment up to 20 m 5x0.75 mm ² up to 40 m 5x1 mm ²	
Special features		LED displays, solenoid A/B Adjustable electronics Preset at the factory, see valve curve Zero, Q _{max} ramp	
Ramp (T _{min})	ms	≈ 50	≈ 90
Dither frequency	Hz	≈ 180	≈ 160
Conformity		 EN 61000-6-2: 2002-08 EN 61000-6-3: 2002-08	

Note:

Power supply 40 V DC_{nom},
max. 31 V DC, max. ripple 2 V DC.

Valve in center position:
Version 0...±10 V
at U_{D-E} ≤ ±0.2 V

Version 4...20 mA
at I_{D-E} = 12 mA
≤ ±0.4 mA

Connection

For electrical data, see page 6 and
Operating Instructions 1 819 929 083

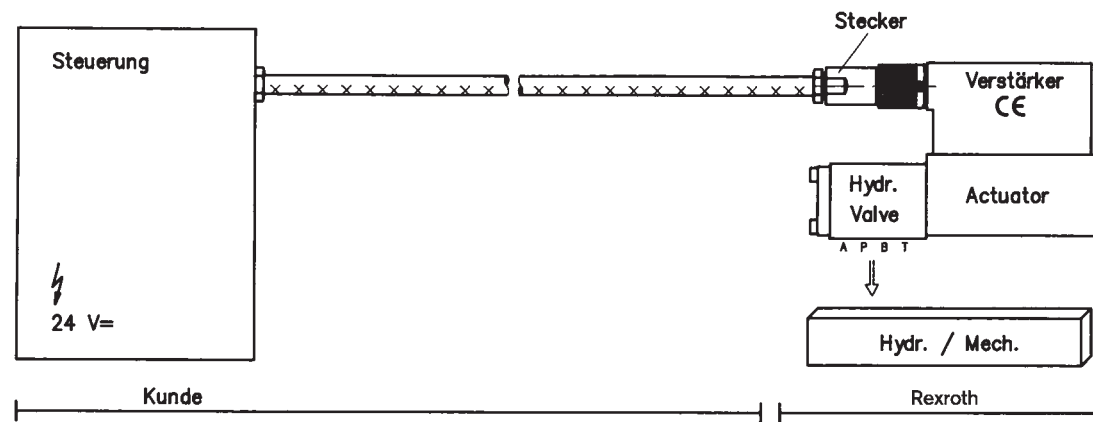

Technical notes for the cable

- Design:**
- Multi-wire cable
 - Extra-finely stranded wire to VDE 0295, Class 6
 - Safety earth conductor, green/yellow
 - Cu braided shield
- Typ:**
- e.g. Ölflex-FD 855 CP (from Lappkabel company)
- No. of wires:**
- Determined by type of valve, plug type and signal assignment
- Cable Ø:**
- 0.75 mm² up to 20 m long
 - 1.0 mm² up to 40 m long
- Outside Ø:**
- 9.4...11.8 mm – Pg11
 - 12.7...13.5 mm – Pg16

Important

Power supply 24 V DC_{nom}
if voltage drops below 18 V DC, rapid shutdown resembling "Enable OFF" takes place internally.
In addition, with the "mA signal" version:
 $I_{D-E} \geq 3 \text{ mA}$ – valve is active
 $I_{D-E} \leq 2 \text{ mA}$ – valve is deactivated.
Electrical signals (e.g. actual values) emitted via the trigger electronics must not be used to shut down safety-relevant machine functions!
(Also see European Standard, "Technical Safety Requirements for Fluid-Powered Systems and Components – Hydraulics", EN 982).

On-board trigger electronics

Circuit diagram/pin assignment

Version F1: I_{D-E} 4...12...20 mA

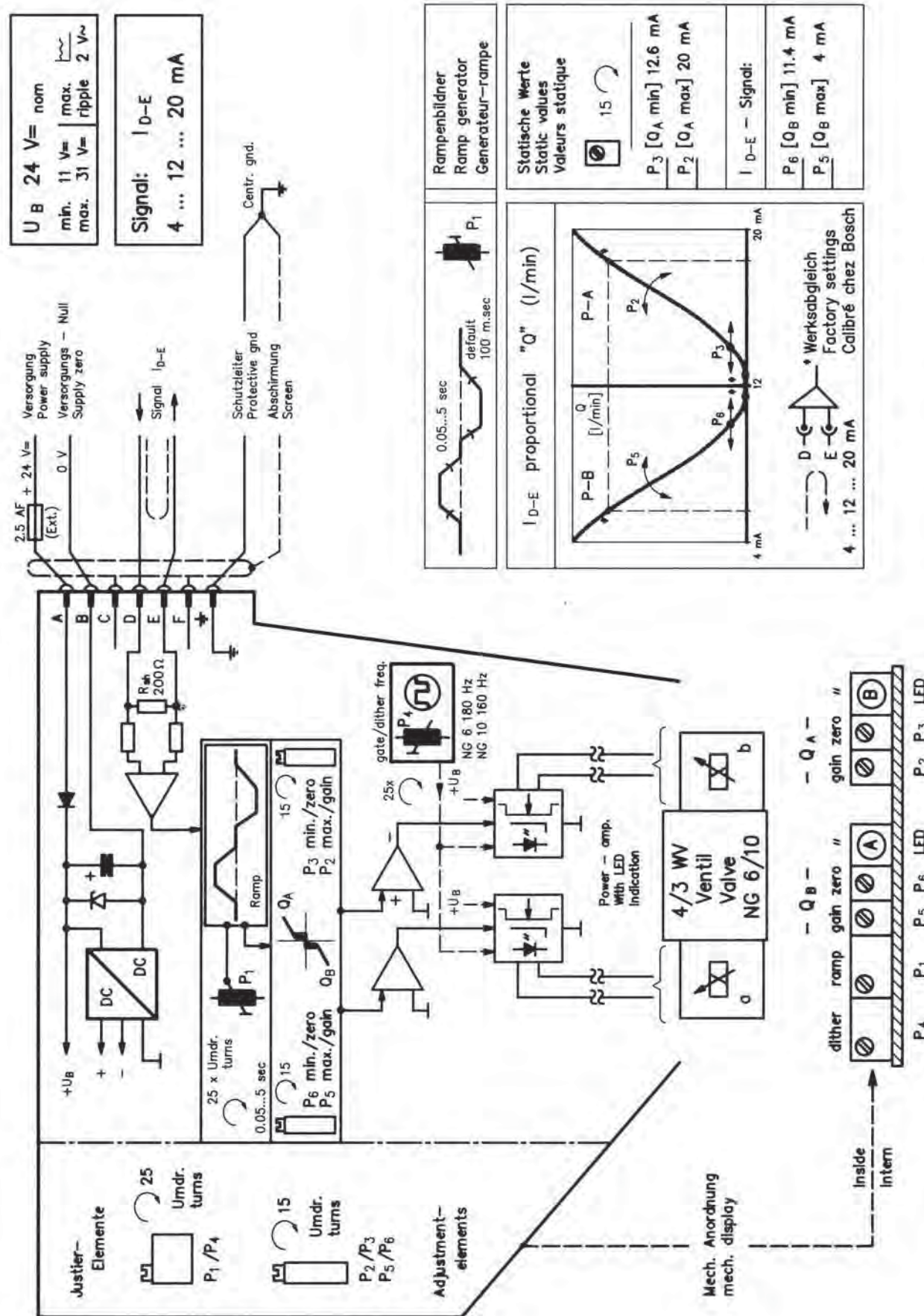

On-board trigger electronics

Pin assignment

Version A1: $U_{D-E} 0...±10 V$
 $R_i = 100 kΩ$

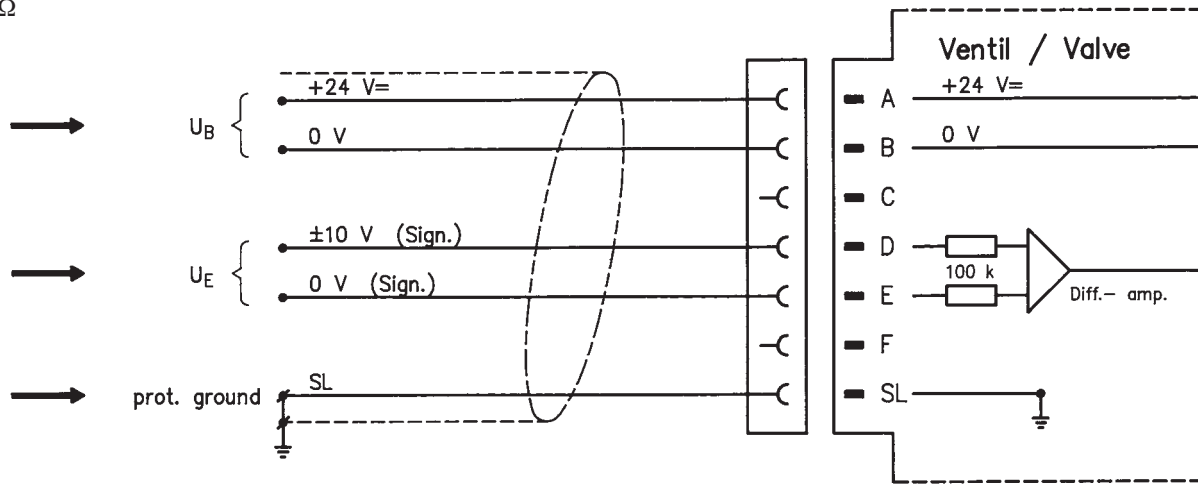

Pin assignment 6P+PE

Version F1: $I_{D-E} 4...12...20 mA$
 $R_{sh} = 200 Ω$

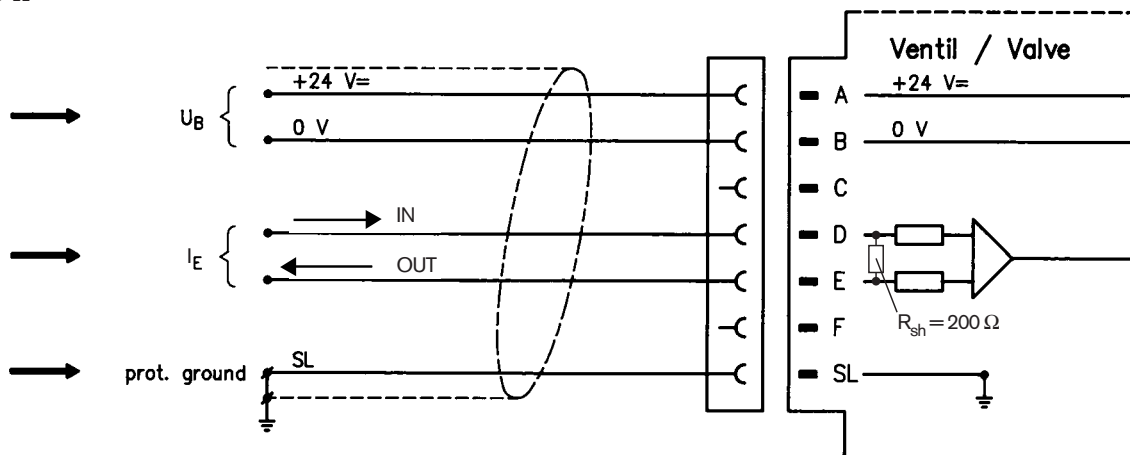

On-board trigger electronics

Valve adjustment

4/3 proportional directional control valves with on-board electronics without position control are preset at the factory. Valves without position control are subject to broader tolerances than valves with position control. Therefore, the design of the valves allows them to be adjusted when installed in the machine.

First, slacken the screws, then open the lid to set the parameters using potentiometers.

Note

The characteristic curve and dither frequency are factory-set. We recommend that you only alter P2...P6 if absolutely necessary.

The P1 ramp is adjustable:

0.05...5 s for 0.8...10 V, or 12.6...20 mA signal change.

For other possibilities, see valve curves.

Adjusting the electronics

First, slacken the screws, then open the lid to set the parameters.

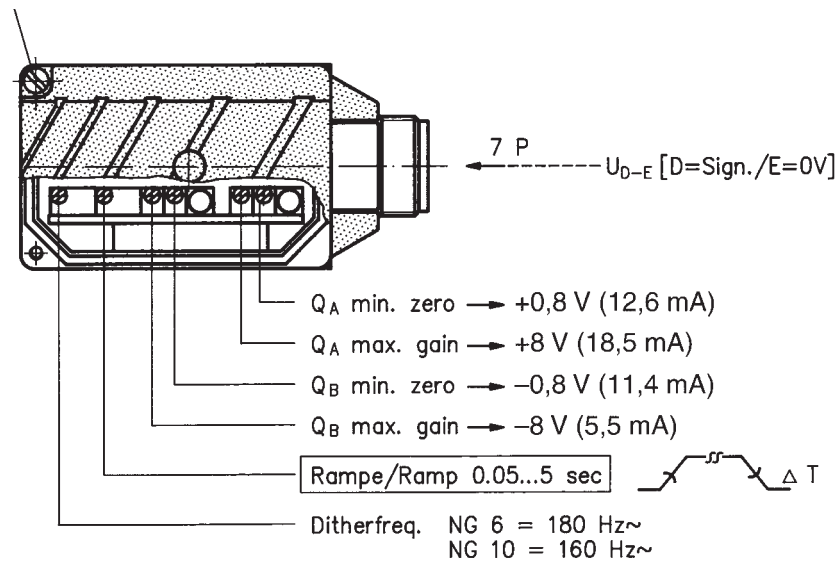

Version: $U_{D-E} = 0...±10 V$

Version: $I_{D-E} = 4...12...20 mA$

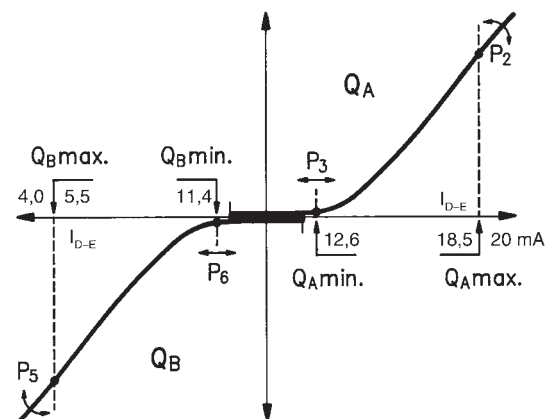
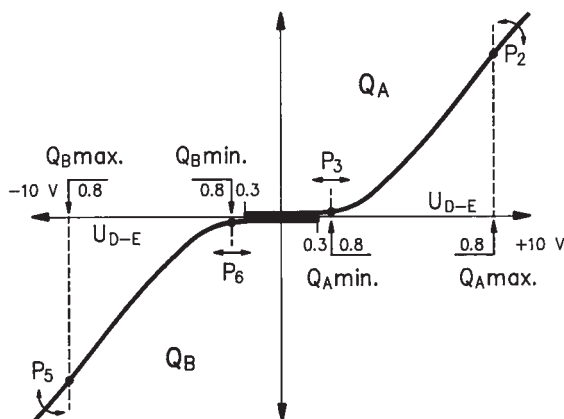

Characteristic curves NG6 (measured with HLP 46, $\vartheta_{oil} = 40^\circ\text{C} \pm 5^\circ\text{C}$)

$Q_{nom} = 18 \text{ l/min}$

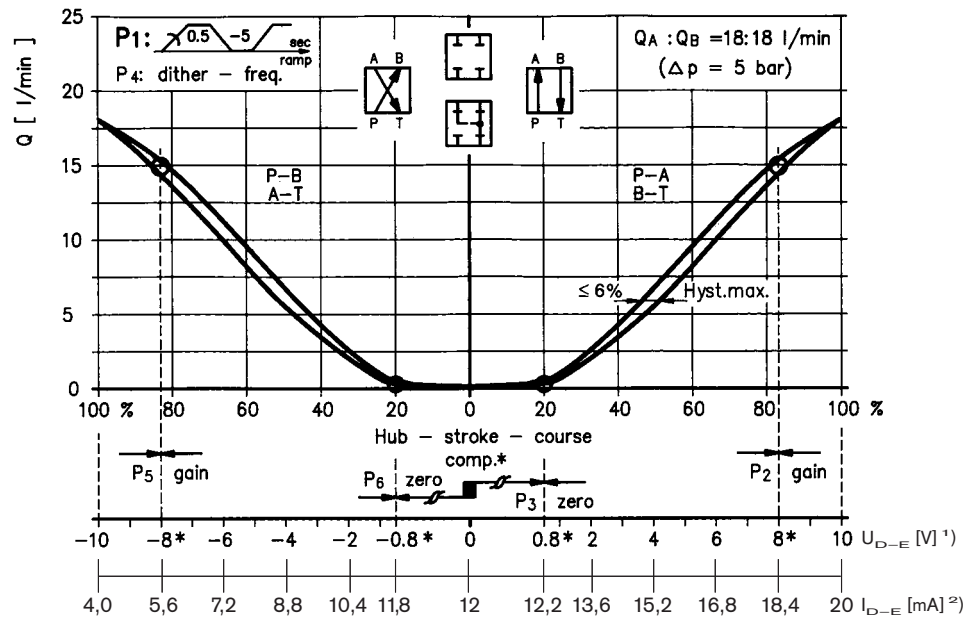

$Q_{nom} = 32 \text{ l/min}$

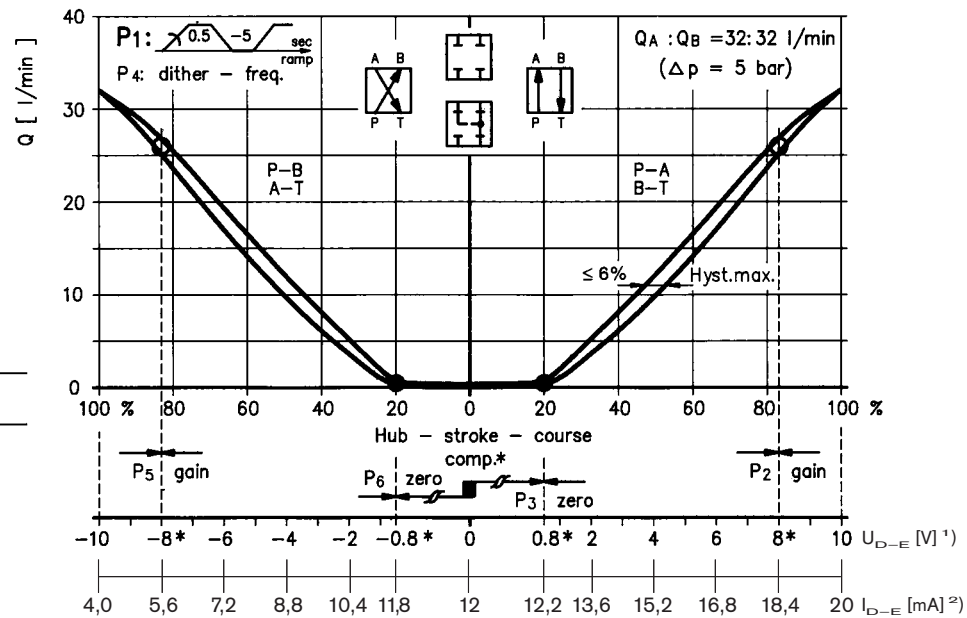

Hinweis/Remark/Note:

- P1 ramp
- P2 ... P6
- * Ab Werk eingestellt
- * Factory calibrated
- * Réglage par l'usine

See page 11
for adjusting the electronics
1) Version: $U_E = 0 \dots \pm 10 \text{ V}$
2) Version: $I_E = 4 \dots 12 \dots 20 \text{ mA}$

Characteristic curves NG6 (measured with HLP 46, $\vartheta_{oil} = 40^\circ\text{C} \pm 5^\circ\text{C}$)

Operating limits

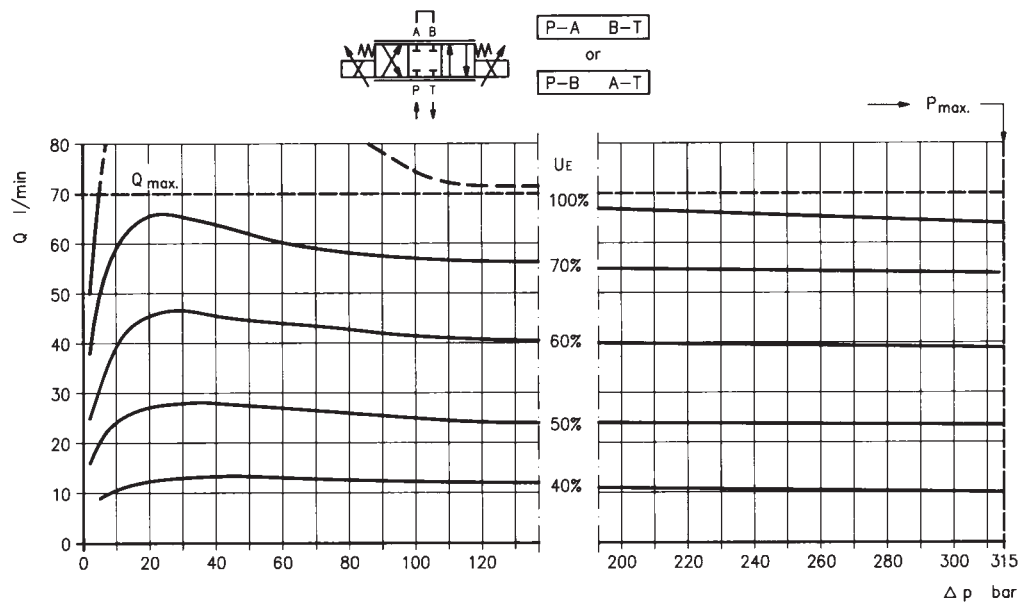
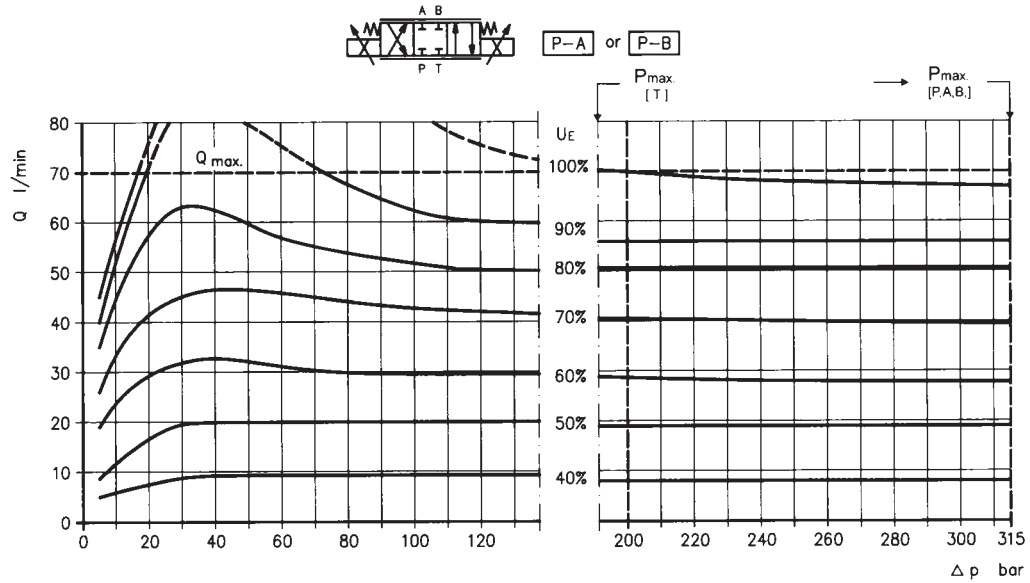

Characteristic curves NG10 (measured with HLP 46, $\vartheta_{oil} = 40^\circ\text{C} \pm 5^\circ\text{C}$)

$Q_{nom} = 35 \text{ l/min}$

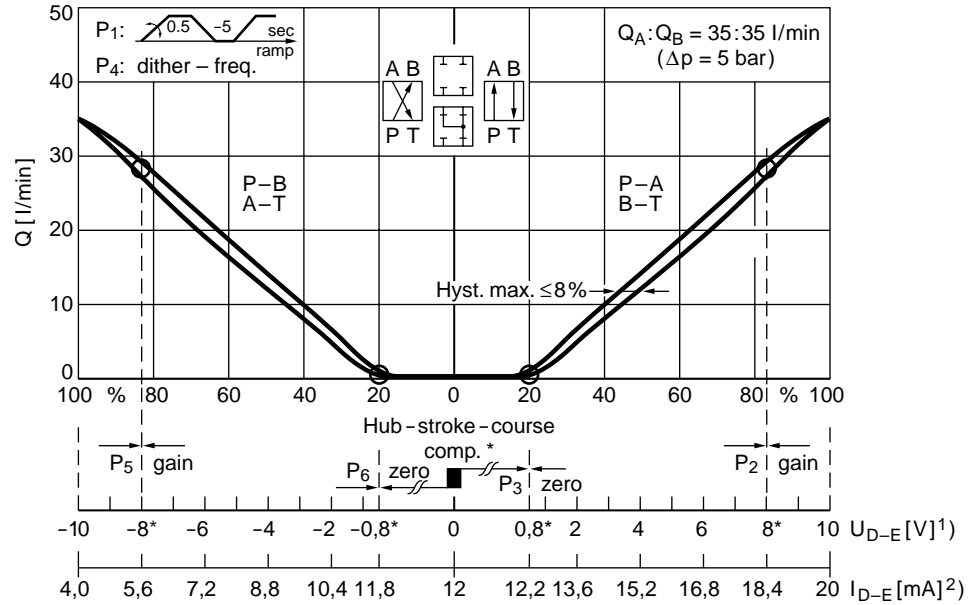

$Q_{nom} = 65 \text{ l/min}$

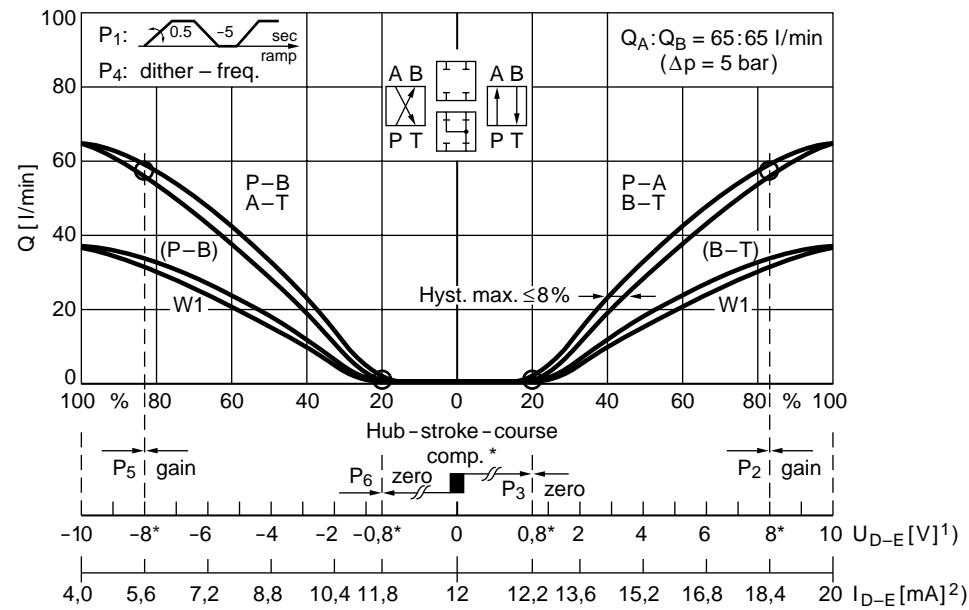

Hinweis/Remark/Note:

- P1 ramp
- P2 ... P6 ↓
- * Ab Werk eingestellt
- * Factory calibrated
- * Réglage par l'usine

See page 11
for adjusting the electronics
1) Version: $U_E = 0... \pm 10 \text{ V}$
2) Version: $I_E = 4...12...20 \text{ mA}$

Characteristic curves NG10 (measured with HLP 46, $\vartheta_{oil} = 40^\circ\text{C} \pm 5^\circ\text{C}$)

Operating limits

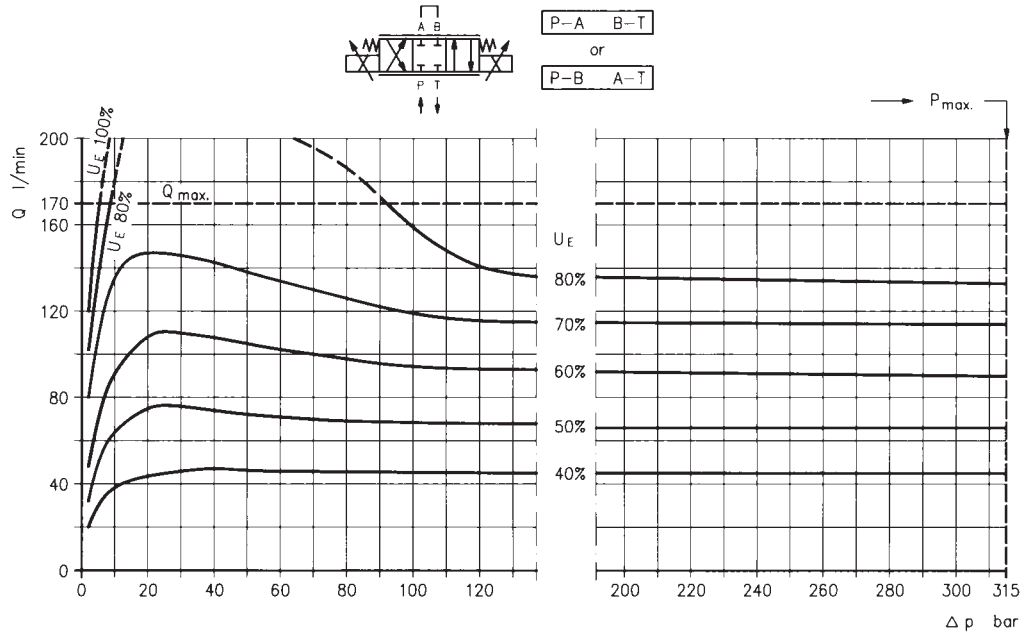
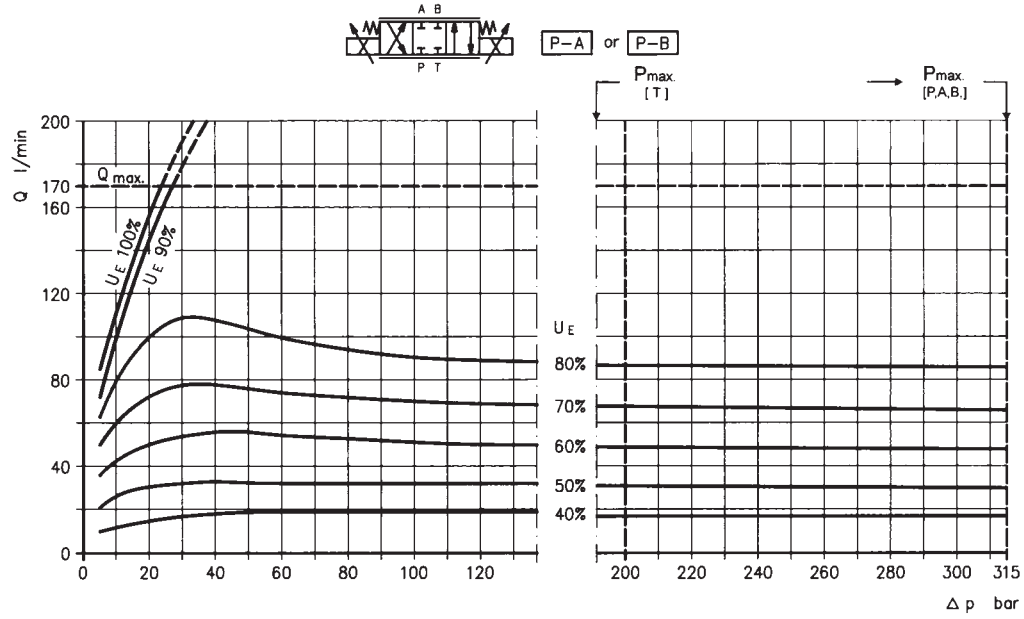

Unit dimensions NG6 (nominal dimensions in mm)

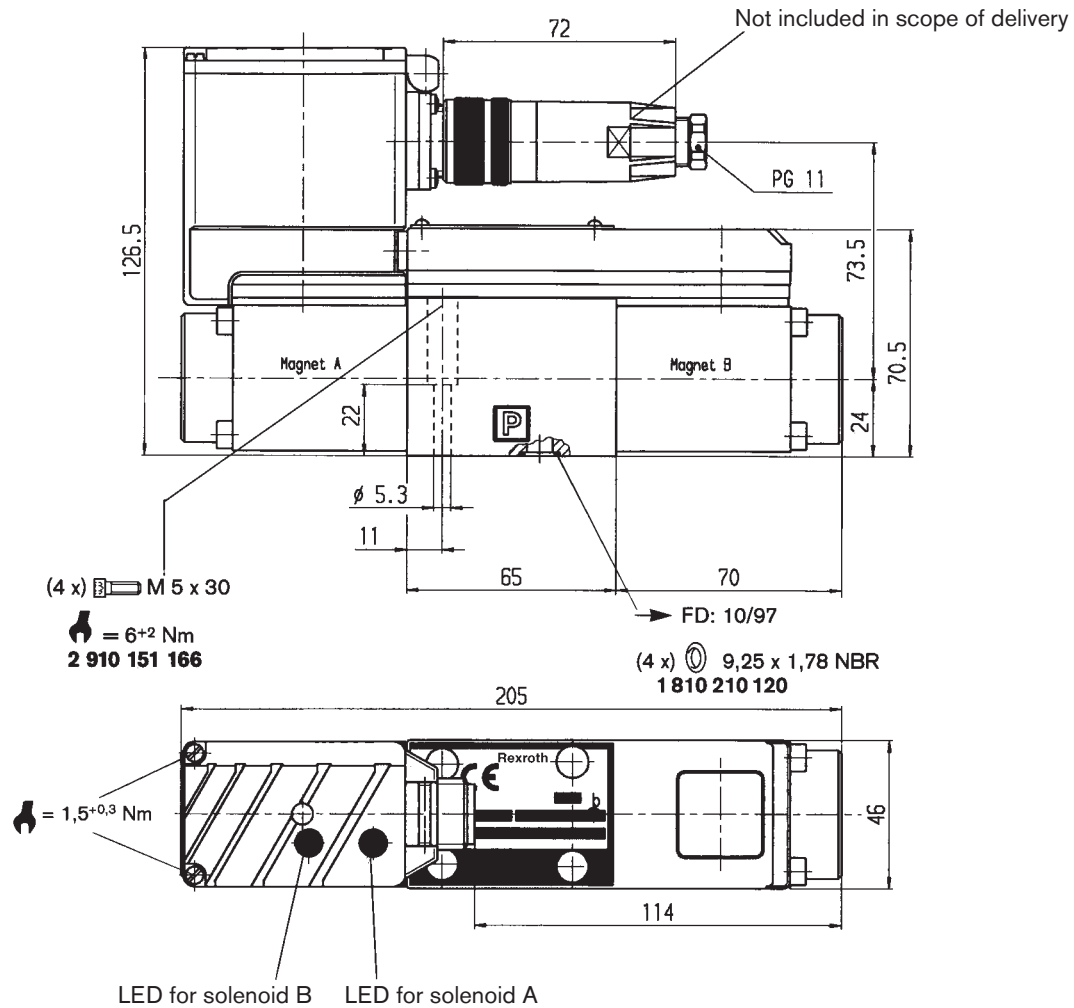

Required surface quality of mating component

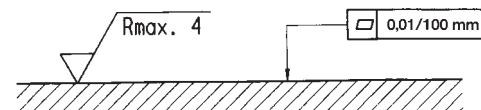

Mounting hole configuration: NG6 (ISO 4401-03-02-0-94)
For subplates, see catalog sheet RE 45053

- ¹⁾ Deviates from standard
- ²⁾ Thread depth:
Ferrous metal 1.5 x Ø
Non-ferrous 2 x Ø

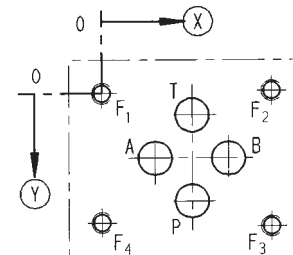

(X)	P	A	T	B	F ₁	F ₂	F ₃	F ₄
(Y)	21.5	12.5	21.5	30.2	0	40.5	40.5	0
Ø	25.9	15.5	5.1	15.5	0	-0.75	31.75	31
	8 ¹⁾	8 ¹⁾	8 ¹⁾	8 ¹⁾	M5 ²⁾	M5 ²⁾	M5 ²⁾	M5 ²⁾

Unit dimensions NG10 (nominal dimensions in mm)

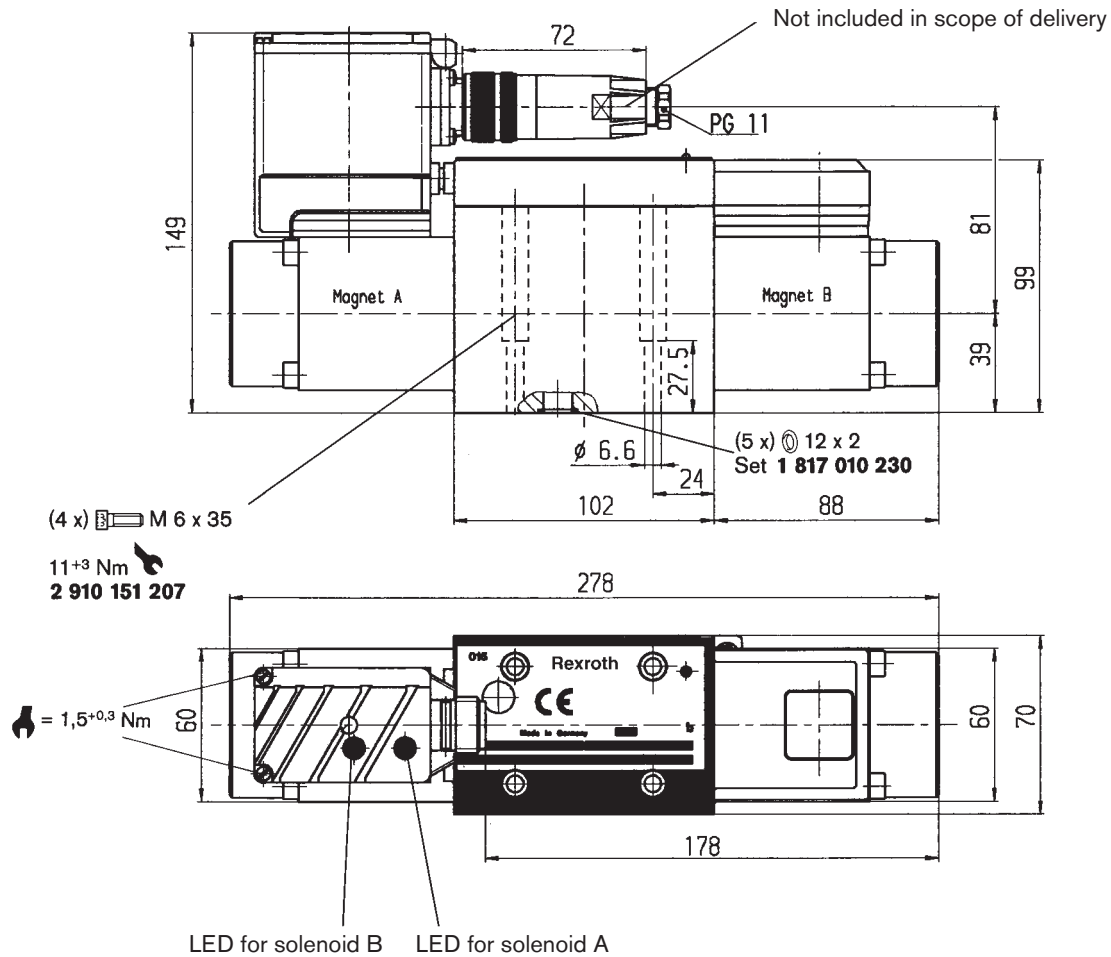

Required surface quality of mating component

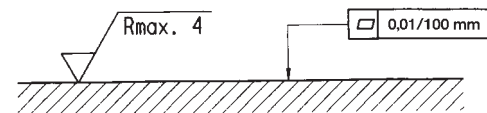

Mounting hole configuration: NG10 (ISO 4401-05-04-0-94)
For subplates, see catalog sheet RE 45055

- 1) Deviates from standard
- 2) Thread depth:
Ferrous metal 1.5 x Ø*
Non-ferrous 2 x Ø
- * NG10 min. 10.5 mm

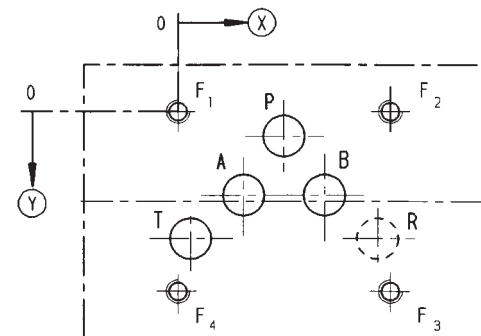

	P	A	T	B	F ₁	F ₂	F ₃	F ₄	R
⊗	27	16.7	3.2	37.3	0	54	54	0	50.8
⊙	6.3	21.4	32.5	21.4	0	0	46	46	32.5
∅	10.5 ¹⁾	10.5 ¹⁾	10.5 ¹⁾	10.5 ¹⁾	M6 ²⁾	M6 ²⁾	M6 ²⁾	M6 ²⁾	10.5 ¹⁾

Notes

Bosch Rexroth AG
Hydraulics
Zum Eisengießer 1
97816 Lohr am Main, Germany
Telefon +49 (0) 93 52 / 18-0
Telefax +49 (0) 93 52 / 18-23 58
documentation@boschrexroth.de
www.boschrexroth.de

© This document, as well as the data, specifications and other information set forth in it, are the exclusive property of Bosch Rexroth AG. It may not be reproduced or given to third parties without its consent.
The data specified above only serve to describe the product. No statements concerning a certain condition or suitability for a certain application can be derived from our information. The information given does not release the user from the obligation of own judgement and verification. It must be remembered that our products are subject to a natural process of wear and aging.

RE 29051/01.06 | 4WRBAE..E.. /..W..

Hydraulics | Bosch Rexroth AG

Notes

Bosch Rexroth AG
Hydraulics
Zum Eisengießer 1
97816 Lohr am Main, Germany
Telefon +49 (0) 93 52 / 18-0
Telefax +49 (0) 93 52 / 18-23 58
documentation@boschrexroth.de
www.boschrexroth.de

© This document, as well as the data, specifications and other information set forth in it, are the exclusive property of Bosch Rexroth AG. It may not be reproduced or given to third parties without its consent.
The data specified above only serve to describe the product. No statements concerning a certain condition or suitability for a certain application can be derived from our information. The information given does not release the user from the obligation of own judgement and verification. It must be remembered that our products are subject to a natural process of wear and aging.

Notes

Bosch Rexroth AG
Hydraulics
Zum Eisengießer 1
97816 Lohr am Main, Germany
Telefon +49 (0) 93 52 / 18-0
Telefax +49 (0) 93 52 / 18-23 58
documentation@boschrexroth.de
www.boschrexroth.de

© This document, as well as the data, specifications and other information set forth in it, are the exclusive property of Bosch Rexroth AG. It may not be reproduced or given to third parties without its consent.
The data specified above only serve to describe the product. No statements concerning a certain condition or suitability for a certain application can be derived from our information. The information given does not release the user from the obligation of own judgement and verification. It must be remembered that our products are subject to a natural process of wear and aging.