

## HYDAC INTERNATIONAL

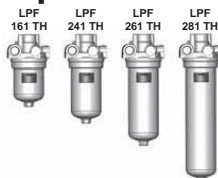

### Inline Filter LPF With Integrated Thermal Bypass Valve up to 140 l/min, up to 50 bar



#### 1. TECHNICAL SPECIFICATIONS

##### 1.1 FILTER HOUSING

###### Construction

The filter housings are designed in accordance with international regulations. They consist of a filter head and a screw-in filter bowl.

Standard equipment:

- with integrated thermal bypass valve
- with bypass valve
- connection for a clogging indicator

##### 1.2 FILTER ELEMENTS

HYDAC filter elements are validated and their quality is constantly monitored according to the following standards:

- ISO 2941, ISO 2942, ISO 2943, ISO 3724, ISO 3968, ISO 11170, ISO 16889

##### Contamination retention capacities in g

LPF/-TH	Betamicon® (BN4HC)			
	3 µm	5 µm	10 µm	20 µm
161	15.2	16.8	20.2	22.9
241	25.1	27.8	33.5	37.9
261	38.8	43.0	51.7	58.5
281	62.4	69.2	83.2	94.1

Filter elements are available with the following pressure stability values:

Betamicon® (BN4HC): 25 bar  
Mobilemicon (MM): 10 bar

##### 1.3 SEALS

Perbunan (= NBR)

##### 1.4 INSTALLATION

As inline filter

##### 1.5 SPECIAL MODELS AND ACCESSORIES

- Seals in FPM, EPDM
- No clogging indicator port

#### 1.6 FILTER SPECIFICATIONS

Nominal pressure	50 bar
Fatigue strength	At nominal pressure 10 <sup>6</sup> cycles from 0 to nominal pressure
Temperature range	-10 °C to +100 °C
Material of filter head	Aluminium
Material of filter bowl	Aluminium
Type of clogging indicator	VM (differential pressure measurement up to 210 bar operating pressure)
Pressure setting of the clogging indicator	5 bar (others on request)
Bypass cracking pressure	3.4 bar

#### 1.7 COMPATIBILITY WITH HYDRAULIC FLUIDS ISO 2943

- Hydraulic oils H to HLPD DIN 51524
- Lubrication oils DIN 51517, API, ACEA, DIN 51515, ISO 6743
- Compressor oils DIN 51506
- Biodegradable operating fluids VDMA 24568 HETG, HEES, HEPG
- Fire-resistant fluids HFC and HFD
- Operating fluids with high water content (>50% water content) on request

#### 1.8 FILTER CALCULATION / SIZING

Curves on request!

The gradient coefficients in mbar/(l/min) apply to mineral oils with a kinematic viscosity of 30 mm<sup>2</sup>/s. The pressure drop changes proportionally to the change in viscosity.

	(BN4HC)			
	3 µm	5 µm	10 µm	20 µm
161	13.4	10.4	6.5	3.5
241	8.1	6.3	3.9	2.1
261	5.2	4.1	2.5	1.4
281	3.3	2.5	1.6	0.9

#### Symbol for hydraulic systems

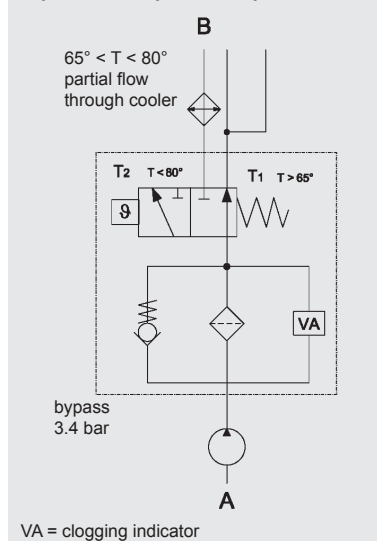

## 2. MODEL CODE

### 2.1 COMPLETE FILTER

Type	Filter material	Size	Pressure range	Type of connection	Filtration rating [µm]	Type of clogging indicator*	Type code	Modification number	Supplementary details
LPF	<b>BN/HC</b> = Betamicon® Glass fibre  <b>MM</b> = Mobilemicron (synthetic fibre)	<b>161</b> <b>241</b> <b>261</b> <b>281</b>	<b>G</b> = 50 bar	<b>I</b> = 1/16-12UN  <b>Z</b> = customer specific  (other connections on request)	<b>BN/HC:</b> <b>3,5,10,20</b>  <b>MM:</b> <b>8, 10, 15</b>	<b>A</b> = steel blanking plug in indicator port  <b>B</b> = visual <b>C</b> = electrical <b>D</b> = visual/ electrical	<b>1</b>	<b>.x</b> = The latest version is always supplied	<b>TH</b> = with integrated thermal bypass It is essential to quote this code! <b>V</b> = FPM seal  <b>L..</b> = light with appropr. voltage (24, 48 110, 220 Volt)

\* for other clogging indicators see brochure no. 7.050../..

### 2.2 REPLACEMENT ELEMENT

Size	Type	Filtration rating [µm]	Filter material	Supplementary details
<b>0161</b> <b>0241</b> <b>0261</b> <b>0281</b>	<b>RD</b> = Return line element for pressure filter	<b>BN4HC:</b> 3, 5, 10, 20 <b>MM:</b> 8, 10, 15	<b>BN4HC</b>  <b>MM</b>	<b>B3.4</b> = with bypass valve (cracking press. 3.4 bar) <b>B6</b> = with bypass valve (cracking press. 6 bar) <b>KB</b> = without bypass valve

### 2.3 REPLACEMENT CLOGGING INDICATOR

Type	Pressure setting	Type of clogging indicator*	Modification number	Supplementary details
<b>VM</b>	<b>5</b> = standard 5 bar	<b>W</b> = no port, no indicator <b>B</b> = visual <b>C</b> = electrical <b>D</b> = visual/ electrical	<b>.x</b> = The latest version is always supplied	<b>-V</b> = FPM seal

## 3. DIMENSIONS

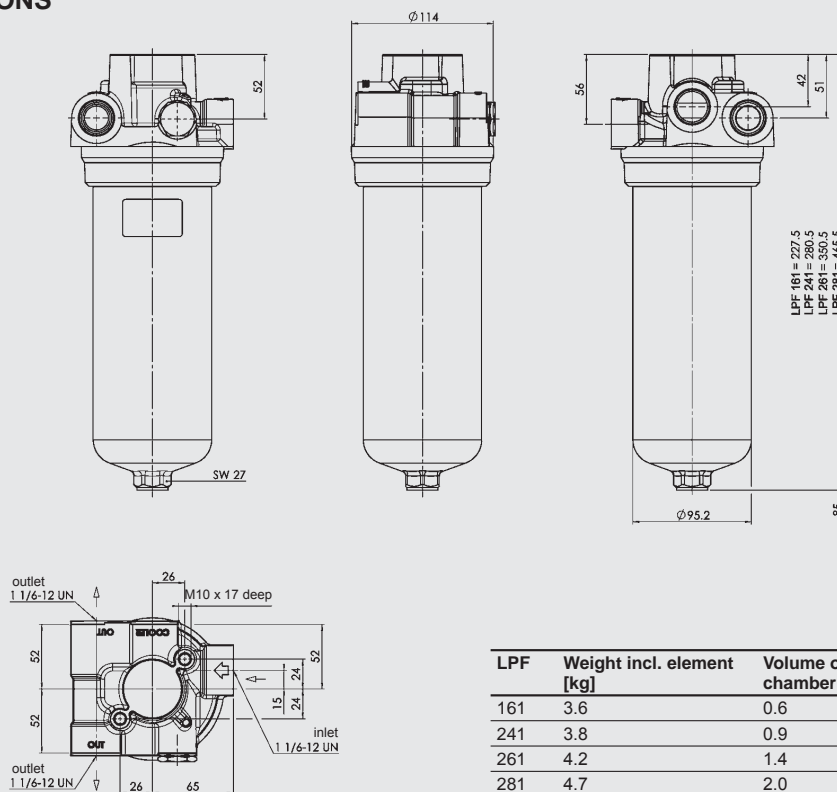

LPF	Weight incl. element [kg]	Volume of pressure chamber [l]
161	3.6	0.6
241	3.8	0.9
261	4.2	1.4
281	4.7	2.0

### NOTE

The information in this brochure relates to the operating conditions and applications described.  
For applications or operating conditions not described, please contact the relevant technical department.  
Subject to technical modifications.

E 7.126.0/03.12