

Electric Drives  
and Controls

Hydraulics

Linear Motion and  
Assembly Technologies

Pneumatics

Service

**Rexroth**  
Bosch Group

## Amplifier module for controlling the explosion-proof proportional pressure valve DBET-6X...XE <sup>1)</sup>

**RE 30223-200/03.11** 1/6  
Replaces: 02.07

Type VT-MSPA1-200

Component series 1X

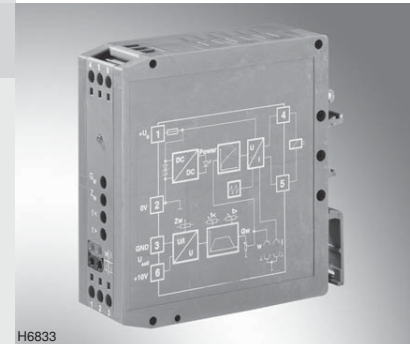

### Table of contents

<b>Contents</b>	
Features	
Ordering code	
Functional description	
Block diagram	
Technical data	
Output characteristic curve	
Terminal assignment	
Device view/unit dimensions	
Important notes	

### Features

<b>Page</b>	
1	– Amplifier module is not subject to the directive 94/9/EC (ATEX directive)
2	– In connection with the Rexroth monitoring module <sup>1)</sup> VT-MUXA2-2 suitable for controlling the proportional pressure valve of type DBET-6X...XE
3	– Inverse-polarity protection of the operating voltage
4	– Differential input for command value voltage +10 V
4	– Ramp generator up and down can be set separately
5	– Zero point potentiometer
5	– 1 command value attenuator
6	– Characteristic curve generator
	– Synchronized power output stage
	– Output short-circuit-proof
	– LED display: <ul style="list-style-type: none"> <li>• Ready for operation (green)</li> </ul>
	– Measuring sockets for: <ul style="list-style-type: none"> <li>• Pressure command value</li> <li>• Actual current value</li> </ul>
	– Dither generator with command value- and operating voltage-dependent frequency

<sup>1)</sup> For the operation of the valve in the explosive area, additional safety measures are required. Here, we recommend using the Rexroth monitoring module VT-MUXA2-2. In this connection, observe data sheet 30290.

## Ordering code

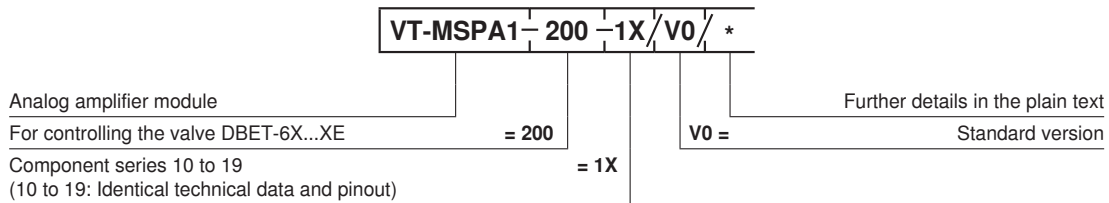

## Functional description

Analog amplifier for controlling pressure valves without electric return. The modular design allows for simple top hat rail assembly as is usual in control cabinets.

( ) = Assignment to the block diagram on page 3

### Command value input (4)

The module amplifier is controlled by means of a standard command value signal 0 to +10 V. By means of the zero point trimmer (Zw) (6), a zero point offset can be corrected.

### Ramp generator (5)

In the ramp generator (5), the actuating variable rise is limited. Using the trimmer "t <" (7), the time for the increasing command value signal is set and using trimmer "t >" (8), the time for the decreasing command value voltage is set. The adjustable time is in each case 30 ms to > 5 s.

### Characteristic curve generator (10)

Using the trimmer "Gw" (9), the rated current of 1.0 A for the solenoid is set. In the characteristic curve generator (10), the command value signal is changed so that a linear command value/pressure characteristic curve results.

### Clock generator (12)

In the clock generator (12), a frequency for the output stage adjusted to the command value is generated.

### Power output stage (11) to (14)

Using the actuating variable coming from the characteristic curve generator (10) and the clock frequency, the power output stage generates a PWM signal that is fed into the solenoid. The solenoid current is recorded and in the current controller (11) compared with the actuating variable and the difference is compensated.

### Fault detection (15)

Monitors the solenoid lines with regard to cable break and short circuit as well as overcurrent of the output stage. If there is an error, the green Ready for operation display goes out.

### Monitoring and limitation of the solenoid current (17)

The VT MUXA2-2 module provides for the monitoring and limitation of the solenoid current. The functioning is described in data sheet 30290.

## Block diagram

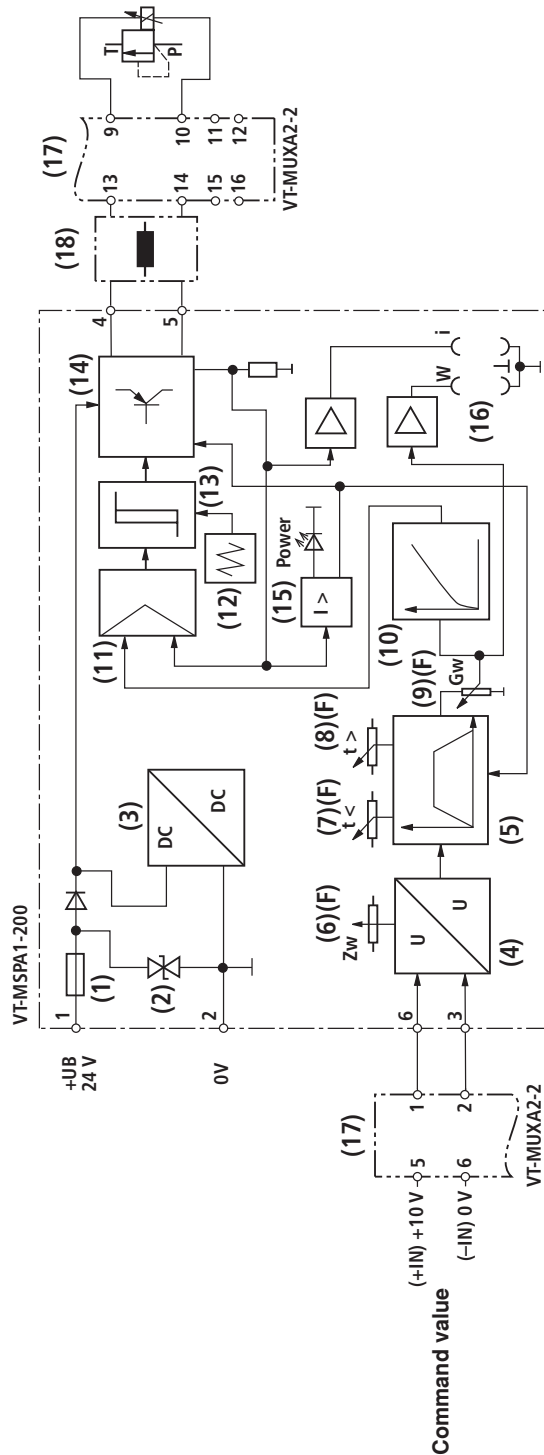

- |                              |                             |                        |  |
|------------------------------|-----------------------------|------------------------|--|
| (1) Fuse                     | (7) Potentiometer ramp up   | (13) Schmitt trigger   | (17) VT-MUXA2-2 monitoring module (order separately)                         |
| (2) Suppressor diode         | (8) Potentiometer ramp down | (14) Output stage      | (18) Ferrite sleeve (only included in the delivery of the monitoring module) |
| (3) Power supply             | (9) Potentiometer $f_{max}$ | (15) Fault recognition |  |
| (4) Command value input      | (10) Linearization          | (16) Measuring socket  |  |
| (5) Ramp generator           | (11) Current controller     | (F) On front side      |  |
| (6) Potentiometer zero point | (12) Oscillator             |                        |  |

## Technical Data (For applications outside these parameters, please consult us!)

Operating voltage	$U_B$	24 VDC +40 % -10 %
Operating range:		
– Upper limit value	$u_B(t)_{max}$	35 V
– Lower limit value	$u_B(t)_{min}$	21 V
Power consumption	$P_{max}$	< 50 VA
Current consumption	$I_{max}$	< 1.3 A
Fuse	$I_s$	Electronic overload protection and SMD fuse (soldered in)
Inputs:		
– Command value (differential input)	$U_{command}$	0 to +10 V; $R_e = 100\text{ k}\Omega$
Outputs:		
– Solenoid current / resistance	$I_{max}$	1.0 A; $R_{20} = 8.3\ \Omega$
– Frequency	$f$	180 to 450 Hz
Setting ranges:		
– GW: Solenoid current	$I$	60 mA...1000 mA
– ZW: Zero point		$\pm 25\%$
– t >: } Ramp	$t$	60 ms...5 sec
– t <: }		
Measuring sockets:		
– Command value "w"	$U$	0 to 10 V
– Actual current value "I"	$U$	1 mV $\triangleq$ 1 mA solenoid current
Type of connection		6 screw terminals
Mounting type		Top hat rail TH 3-7.5 according to EN 60715
Protection class		IP 20 according to EN 60529
Dimensions (W x H x D)		25 x 79 x 85.5 mm
Admissible operating temperature range	$\vartheta$	0 to +50 °C
Storage temperature range	$\vartheta$	-25 to +85 °C
Weight	$m$	0.15 kg

### Note!

For information on the environment simulation testing for the areas EMC (electromagnetic compatibility), climate and mechanical load, see data sheet 30223-U.

## Output characteristic curve

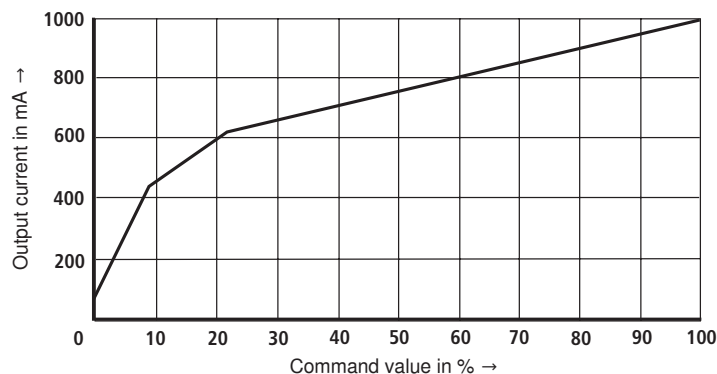

## Terminal assignment

Terminal	
1	$+U_B$
2	Ground
3	$-U_{\text{command}}$
4	Solenoid +
5	Solenoid -
6	$+U_{\text{command}}$

## Device view/unit dimensions (dimensions in mm)

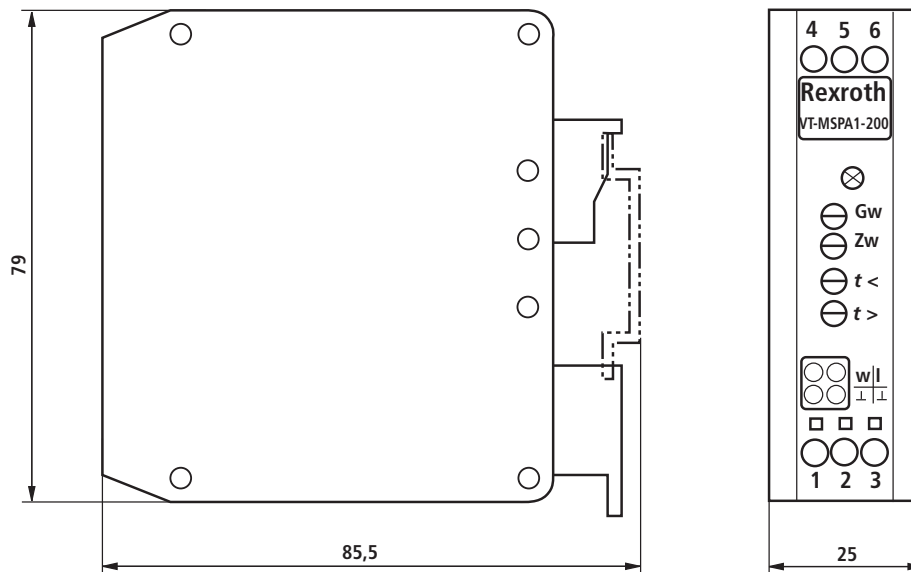

**Potentiometer:** "Gw" Pressure command value  
 "Zw" Zero point  
 "t <" Ramp time up  
 "t >" Ramp time down

**Sockets:** "w" Pressure command value  
 "|l" Actual current value  
 "|l" Measurement null

## Important notes

### Explosion hazard caused by incorrect assembly!

For achieving the prescribed safety when operating the valve in the explosive area, it has to be ensure that the solenoid current does not exceed 1 A. For monitoring and limiting the valve current, we recommend using the Rexroth monitoring module VT-MUXA2-2. In this connection, observe data sheet 30290.

The VT-MSPA1-200 amplifier module and the VT-MUXA2-2 monitoring module may only be installed outside the explosive area!

The VT-MSPA1-200 amplifier module and the VT-MUXA2-2 monitoring module are not subject to the directive 94/9/EC (ATEX directive)!

More information:

- The amplifier module may only be wired when de-energized!
  - Do not lay signal lines close to power cables and lines!
  - Do not use free-wheeling diodes in the solenoid lines!
  - The distance to aerial lines, radios, and radar systems has to be 1 m at least!
  - Always shield command value lines, connect shielding to protective earthing (PE) on the module side!
    - Also shield the solenoid lines!
    - For solenoid lines up to 50 m in length, use the line type LiYCY 1.5 mm<sup>2</sup>!
    - With greater lengths please consult us!
    - In applications in connection with the VT-MUXA2-2 monitoring module, please observe the wiring specified in the block diagram of data sheet 30290.
  - For switching command values, relays with gold-plated contacts have to be used (small voltages, low currents)!
  - Only carry out measurements at the module using instruments with  $R_i > 100 \text{ k}\Omega$ .
  - For setting the potentiometers, use a screwdriver with a blade width of 4 mm!
  - With a strongly fluctuating operating voltage, it may in the individual case be necessary to use an external smoothing capacitor with a capacity of at least 2200  $\mu\text{F}$ .
- Recommendation: Capacitor module VT 11110 (see data sheet 30750), sufficient for up to 3 amplifier modules

© This document, as well as the data, specifications and other information set forth in it, are the exclusive property of Bosch Rexroth AG. It may not be reproduced or given to third parties without its consent. The data specified above only serve to describe the product. No statements concerning a certain condition or suitability for a certain application can be derived from our information. The information given does not release the user from the obligation of own judgment and verification. It must be remembered that our products are subject to a natural process of wear and aging.