

Electric Drives  
and Controls

Hydraulics

Linear Motion and  
Assembly Technologies

Pneumatics

Service

**Rexroth**  
Bosch Group

## Pressure switch Type HEDE10.../1/

**RE 30276-B/10.10**

Replaces: 06.10

### Operating instructions



## Contents

1	Overview of menu.....	3
2	Safety note.....	4
3	Operating and indicator elements.....	4
4	Proper use .....	5
4.1	Application .....	5
5	Operating modes .....	6
5.1	Run mode .....	6
5.2	Display mode.....	6
5.3	Programming mode .....	7
6	Installation .....	7
7	Electrical connection .....	8
8	Programming .....	10
9	Commissioning / operation .....	11
10	Technical information / operating principle / parameters ...	12
10.1	Adjustable parameters.....	12
11	Hysteresis function / window function.....	15
11.1	Hysteresis function .....	15
11.2	Window function .....	15
12	Technical data .....	16
13	Unit dimensions .....	18

RE 30276-B/10.10 | HEDE10.../1/

Bosch Rexroth AG 3/20

## 1 Overview of menu

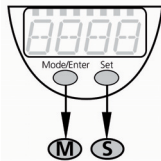
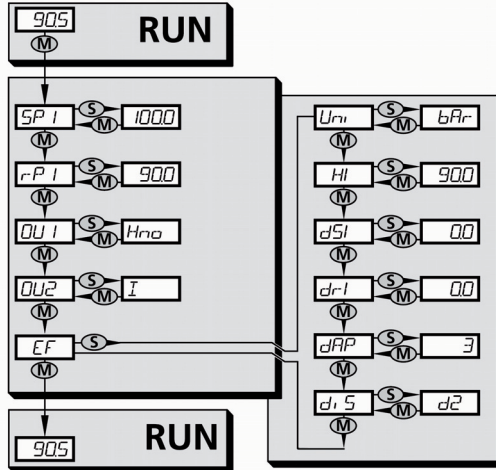

## 2 Safety note

Read this product description before commissioning the device. Make sure that the product is suitable for the relevant application (sg) without any restrictions. The non-observance of notes on the operation or technical information can result in damage to property and/or personal injury. Verify for all applications the compatibility of the product materials (see Technical data) with the pressure media to be measured.

## 3 Operating and indicator elements

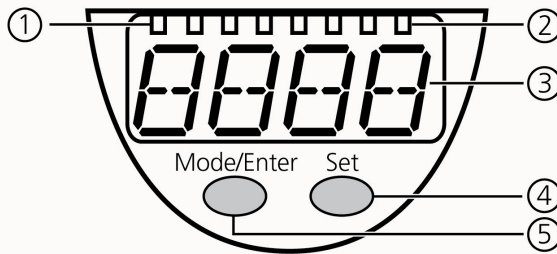

1	3 x LED green	LED ON = set display unit
2	1 x LED yellow	Indication of the switching status; is illuminated when the contact of the relevant output is closed/opened
3	4-digit display	Indication of system pressure, parameters and parameter values
4	Set key	Adjustment of parameter values (continuing by holding the key depressed; step by step by pressing the key repeatedly)
5	Mode / Enter key	Selection of parameters and acknowledgement of parameter values

RE 30276-B/10.10 | HEDE10.../1/

Bosch Rexroth AG 5/20

## 4 Proper use

- The pressure sensor senses the system pressure in hydraulic installations,
- shows it on a display
- and generates 2 output signals according to the set output configuration.

Output 1	Output 2
Hysteresis function / normally open contact ( <b>Hno</b> )	<i>I</i> : 4 ... 20 mA
Hysteresis function / normally closed contact ( <b>Hnc</b> )	
Window function / normally open contact ( <b>Fno</b> )	<i>U</i> : 0 ... 10 V
Window function / normally closed contact ( <b>Fnc</b> )	

## 4.1 Application

Ordering code	Measuring range	Permissible overpressure	Burst pressure
HEDE10-1X/100	0 ... 100 bar	300 bar	650 bar
HEDE10-1X/250	0 ... 250 bar	400 bar	850 bar
HEDE10-1X/400	0 ... 400 bar	600 bar	1000 bar
HEDE10-1X/600	0 ... 600 bar	800 bar	1200 bar



Avoid steady-state and dynamic overpressures that exceed the specified measuring range.

The device can be destroyed, when the specified overload pressure is exceeded only briefly.

Reaching the burst pressure represents a risk of personal injury.

High-pressure components (400 bar, 600 bar) are provided with an integrated throttle feature in order to prevent the risk of personal injury in case of bursting when the burst pressure is exceeded and in order to comply with the regulations for UL approval.

If the throttle feature is removed:

- the device can no longer be used in accordance with UL regulations,
- the throttle feature can be rendered inoperable.

Should you have any queries, please contact Bosch Rexroth.

## 5 Operating modes

### 5.1 Run mode

(Normal operating mode)

Following the application of the supply voltage, the device is ready for operation after 0.3 s and is then in the run mode. It performs its monitoring function and issues output signals according to the set parameters. The display shows the current system pressure and the yellow LEDs signal the switching status of the outputs.

## 5.2 Display mode

(Indication of parameters and set parameter values)

To switch the device over to the display mode, briefly press the "Mode/Enter" key. Internally, it remains in the run mode. The set parameter values can then be read independently of this:

- To scroll through the parameters, briefly press the "Mode/Enter" key.
- When you briefly press the "Set" key, the associated parameter value is displayed for 15 s. After further 15 s, the device returns to the run mode.

## 5.3 Programming mode

(Adjustment of parameter values)

The device changes over to the programming mode when a parameter is selected and then the "Set" key pressed for longer than 5 s (the parameter value flashes on the display and is then continuously increased). The device remains in the run mode also in this case. It continues to perform its monitoring functions with the set parameters until the change of parameters is completed. You can change the parameter value with the help of the "Set" key and confirm the setting by pressing the "Mode/Enter" key. The device returns to the run mode when no key is pressed for 15 s.

## 6 Installation



Before installing or removing the sensors, make sure that the system is depressurized.

Install the pressure sensor at a G $\frac{1}{4}$  process port with a screwed plug according to DIN 3852-A-G  $\frac{1}{4}$ .

The tightening torque is 25 Nm  $\pm$  20 %.

8/20 Bosch Rexroth AG

HEDE10.../1 | RE 30276-B/10.10

## 7 Electrical connection



The device may be installed exclusively by an electrical specialist.

Please observe the national and international regulations for the installation of electrotechnical systems.

Voltage supply according to EN50178, SELV, PELV

For applications, for which an UL approval is required, the device shall be supplied from an isolating transformer having a secondary Listed fuse rated as noted in the following table.

Overcurrent protection		
Control-circuit wire size		Maximum protective device rating in Ampere
AWG	(mm <sup>2</sup> )	
26	(0.13)	1
24	(0.20)	2
22	(0.32)	3
20	(0.52)	5
18	(0.82)	7
16	(1.3)	10

The Sensor shall be connected only by using any R/C (CYJV2) cord, having suitable ratings.

Disconnect the system from the power supply and connect the device as follows:

RE 30276-B/10.10 | HEDE10.../1/

Bosch Rexroth AG 9/20

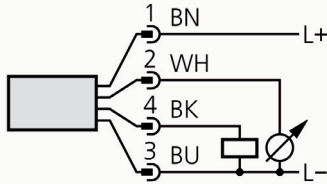

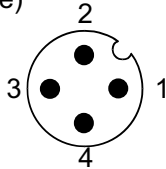

Plug-in connector (on device)

Colors of conductors for Bosch Rexroth plug-in connectors:

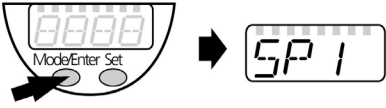
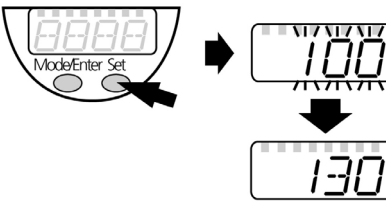

- 1 = BN (brown)
- 2 = WH (white)
- 3 = BU (blue),
- 4 = BK (black)

## 8 Programming

1		<p>Press the <b>Mode/Enter</b> key until the <b>desired parameter</b> is shown on the display.</p>
2		<p>Press and hold the <b>Set</b> key. The <b>current parameter value flashes</b> on the display for 5 s, then it is <b>increased*</b> (stepwise when pressing the key repeatedly or continuously by holding the key depressed).</p>
3		<p><b>Briefly</b> press the <b>Mode/Enter</b> key (= acknowledgement). The parameter is displayed again, the new <b>parameter value becomes effective</b>.</p>
4	<p><b>To change further parameters:</b> Start again with step 1.</p>	<p><b>Complete programming:</b> Wait for 15 s or press the Mode/Enter key until the current measured value is displayed again</p>

RE 30276-B/10.10 | HEDE10.../1/

Bosch Rexroth AG 11/20

\*Reducing the value: Let the display run up to the maximum setting. Then, the cycle restarts with the minimum setting.

Set the displayed unit (Uni) before you determine the switching limits (SP1, rP1). In this way you can prevent rounding errors in the internal recalculation to other units and obtain exactly the required values. Factory setting: **Uni = bar**.

If no key is pressed for 15 s during the adjustment procedure, the device changes back to the run mode with unchanged values.

The device can be electronically interlocked so that unintended, incorrect entries can be avoided: Press both adjustment keys in the run mode until "Loc" is displayed. For unlocking, press the keys until "uLoc" is shown.

Factory setting: Not locked.

When the device is locked, "Loc" is briefly shown on the display when you attempt to change the parameter values.

## 9 Commissioning / operation

After installation, electrical connection and programming are completed, check that the devices operates safely.

Fault messages during operation:

OL	Overload pressure (= measuring range exceeded)
UL	Underload pressure (= below measuring range)
SC 1	Flashing: Short-circuit in switching output 1 *

\* The relevant output is switched off as long as the short-circuit is present. These signals are also given when the display is switched off.

12/20 Bosch Rexroth AG

HEDE10.../1 | RE 30276-B/10.10

## 10 Technical information / operating principle / parameters

### 10.1 Adjustable parameters

<i>SP 1</i>	<p><b>Switching point 1</b></p> <p>Upper limit value, at which the output changes its switching status.</p> <p>Adjustment range: See Technical data</p>
<i>rP 1</i>	<p><b>Switch-back position 1</b></p> <p>Lower limit value, at which the output changes its switching status.</p> <p>rP1 is always smaller than SP1. Only values can be entered that are lower than the value of SP1.</p> <p>When the switching point is changed, the switch-back point is adjusted as well (the difference between SP1 and rP1 remains constant). If the difference is greater than the new switching point, it is automatically reduced (rP1 is set to the minimum setting).</p> <p>Adjustment range: See Technical data</p>
<i>OU 1</i>	<p><b>Configuration of the switching output</b></p> <p>4 switching functions can be adjusted:</p> <ul style="list-style-type: none"> <li>- <b>Hno</b> = Hysteresis function / normally open (NO)</li> <li>- <b>Hnc</b> = Hysteresis function / normally closed (NC)</li> <li>- <b>Fno</b> = Window function / normally open (NO)</li> <li>- <b>Fnc</b> = Window function / normally closed (NC)</li> </ul>
<i>OU 2</i>	<p><b>Configuration of the analog output</b></p> <p>2 analog signals can be adjusted:</p> <ul style="list-style-type: none"> <li>- <b>I</b> = Analog output 4 ... 20 mA</li> <li>- <b>U</b> = Analog output 0 ... 10 V</li> </ul>

RE 30276-B/10.10 | HEDE10.../1/

Bosch Rexroth AG 13/20

<p><i>EF</i></p>	<p><b>Extended functions</b></p> <p>This menu item includes a sub-menu with further parameters. To access these parameters, briefly press the "Set" key.</p> <p>If access is protected by means of an access code, "Cod1" flashes on the display.</p> <ul style="list-style-type: none"> <li>• Press the "Set" key and hold it down until the valid code no. is shown.</li> <li>• Then, briefly press the "Mode/Enter" key.</li> </ul> <p>Factory setting without access restriction</p>
<p><i>Uni</i></p>	<p><b>Displayed unit</b></p> <p>Measured values and values for SPx, rPx can be displayed in the following units:</p> <p><b>bAr</b> (= bar), <b>PSI</b>, <b>PA</b> (= MPa).</p> <p>Set the displayed unit <b>before</b> you determine the switching limits (SPx, rPx). In this way you can prevent rounding errors in the internal recalculation to other units and obtain exactly the required values.</p> <p>Factory setting: <b>Uni = bAr</b>.</p>
<p><i>HI</i></p>	<p><b>Max system pressure log</b></p> <ul style="list-style-type: none"> <li>• HI: Indication of the highest pressure measured.</li> </ul> <p>Clearing the log:</p> <ul style="list-style-type: none"> <li>- Press the "Mode/Enter" key until "HI" is displayed.</li> <li>- Press the "Set" key and hold it down until "- - -" is shown on the display.</li> <li>- Then, briefly press the "Mode/Enter" key.</li> </ul>

14/20 Bosch Rexroth AG

HEDE10.../1 | RE 30276-B/10.10

<p><i>dS 1</i></p> <p><i>dr 1</i></p>	<p><b>Delay time for switching outputs</b></p> <p><b>dS1</b> = switch-on delay; <b>dr1</b> = switch-off delay.</p> <p>The output does not change its switching status immediately after the switching event occurred, but only after the delay time elapsed. If the switching event is no longer present after the delay time has elapsed, the switching status of the output will not be changed.</p> <ul style="list-style-type: none"> <li>Adjustment range: 0 / 0,20 ... 50 s in increments of 0.2 s (0 = delay time not active)</li> </ul>																				
<p><i>dAP</i></p>	<p><b>Attenuation for outputs</b></p> <p>This function can be used to filter out brief pressure peaks or high-frequency pressure peaks.</p> <p>dAP value = response time between the change in pressure and change in the switching status in milliseconds (ms).</p> <p>The following, fixed values can be set; they determine the switching frequency (f) of the output:</p> <table border="1"> <tr> <td>dAP</td> <td>3</td> <td>6</td> <td>10</td> <td>17</td> <td>30</td> <td>60</td> <td>125</td> <td>250</td> <td>500</td> </tr> <tr> <td>f [Hz]</td> <td>170</td> <td>80</td> <td>50</td> <td>30</td> <td>16</td> <td>8</td> <td>4</td> <td>2</td> <td>1</td> </tr> </table>	dAP	3	6	10	17	30	60	125	250	500	f [Hz]	170	80	50	30	16	8	4	2	1
dAP	3	6	10	17	30	60	125	250	500												
f [Hz]	170	80	50	30	16	8	4	2	1												
<p><i>d1 5</i></p>	<p><b>Setting of the display</b></p> <p>7 settings can be selected.</p> <p><b>d1</b> = measured values are updated every 50 ms.</p> <p><b>d2</b> = measured values are updated every 200 ms.</p> <p><b>d3</b> = measured values are updated every 600 ms.</p> <p>The update of measured values only refers to the display. It has no effect on the outputs.</p> <p><b>rd1, rd2, rd3</b> = indication as with d1, d2, d3; but rotated by 180°.</p> <p><b>OFF</b> = the indication of measured values is switched off in the run mode.</p>																				

RE 30276-B/10.10 | HEDE10.../1/

Bosch Rexroth AG 15/20

When you press one of the keys, the current measured values is displayed for 15 s. Repeated pressing of the Mode/Enter key opens the display mode. The LEDs remain active even when the display is switched off.

## 11 Hysteresis function / window function

### 11.1 Hysteresis function

The hysteresis function maintains the switching status of the output stable when the system pressure fluctuates around the command value.

When the system pressure increases, the output switches when the switching point (SP1) is reached; when the system pressure falls again, the output only switches back when the switch-back point (rP1) is reached. The hysteresis can be adjusted: First determine the switching point, then the switch-back point with the required difference.

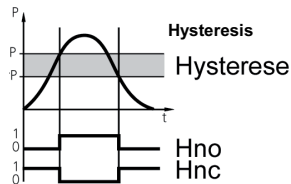

### 11.2 Window function

The window function allows monitoring of a defined "good" range. When the system pressure lies between switching point (SP1) and switch-back point (rP1), the output is closed (window function / normally open contact) or opened (window function / normally closed contact). The width of the window can be adjusted by determining the difference of SP1 to rP1. SP1 = upper value, rP1 = lower value.

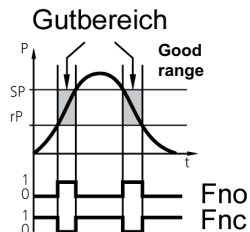

16/20 Bosch Rexroth AG

HEDE10.../1 | RE 30276-B/10.10

## 12 Technical data

Auxiliary power [V]	18 ... 36 DC
Current consumption [mA]	< 50
Current carrying capacity per switching output [mA]	250
Short-circuit protection	
Protected against polarity reversal / overload-proof	up to 40 V
Integrated watchdog	
Voltage drop [V]	< 2
Readiness delay time [s]	0.3
Switching frequency [Hz]	170 ... 1
Analog output	4 ... 20 mA / 0 ... 10 V
Max. load of current output [ $\Omega$ ]	$(UB - 10) \times 50$ ; 700 at $UB = 24$ V
Min. load at voltage output [ $\Omega$ ]	2000
Adjustment time of analog output [ms]	< 3
Accuracy / deviations / in % of the final measuring range value <sup>1)</sup>	
Matching error <sup>2)</sup>	< $\pm 0.5$
Hysteresis	< $\pm 0.25$ (< $\pm 0.5$ (HEDE10A1-2X/600))
Repeatability	< $\pm 0.1$
Long-term drift (in % of the final measuring range value per 6 months)	< $\pm 0.05$
- Temperature coefficients (TC) in the compensated temperature range of 0 ... 80 °C (in % of the final measuring range value)	
- Greatest TC of the zero point	0.2
- Greatest TC of the span	0.2
Materials in contact with the medium	V2A (1.4305); ceramic; FKM
Housing materials	V2A (1.4301); V4A (1.4404); PBTP (Pocan); PC (Macrolon); PEI; FKM
Type of protection, type of housing	IP 67 (IEC60529)
Protection class	III (EN50178)
Insulation resistance [ $M\Omega$ ]	> 100 (500 V DC)
Shock resistance [g]	50 (DIN / IEC 68-2-27, 11 ms)
Resistance to vibration [g]	20 (DIN / IEC 68-2-6, 10 – 2000 Hz)

RE 30276-B/10.10 | HEDE10.../1/

Bosch Rexroth AG 17/20

Switching cycles min.100 million (50 million at pressure range 600 bar)	
Ambient temperature [°C]	-20 ... +80
Medium temperature [°C]	-25 ... +80
Storage temperature [°C]	-40 ... +100
EMC EN 61000-4-2 ESD:	4 / 8 KV
EN 61000-4-3 HF irradiated:	10 V/m
EN 61000-4-4 Burst:	2 KV
EN 61000-4-5 Surge:	0.5 / 1 KV
EN 61000-4-6 HF conducted:	10 V

Adjustment ranges:

HEDE10A1-2X/100	1 to 100 bar
HEDE10A1-2X/250	2 to 250 bar
HEDE10A1-2X/400	4 to 400 bar
HEDE10A1-2X/600	6 to 600 bar

<sup>1)</sup> related to the display  $\pm 1$  digit

<sup>2)</sup> Initial point setting according to DIN 16086

18/20 Bosch Rexroth AG

HEDE10.../1/ | RE 30276-B/10.10

## 13 Unit dimensions

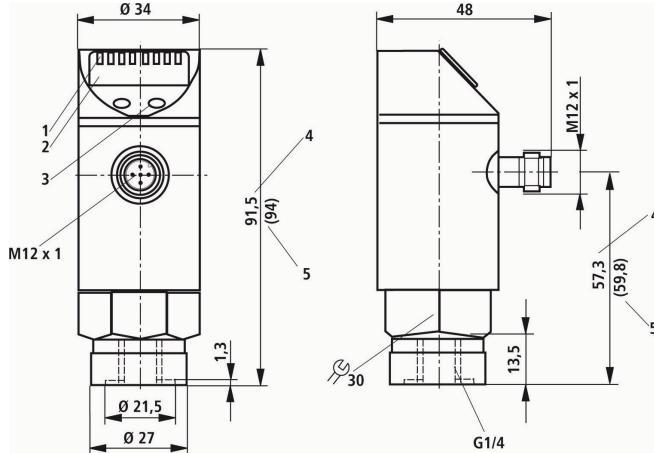

- 1 LEDs
- 2 Display
- 3 Programming key
- 4 Dimensions given for pressure ranges 100 and 250 bar
- 5 Dimensions given for pressure ranges 400 and 600 bar

RE 30276-B/10.10 | HEDE10.../1/

Bosch Rexroth AG 19/20

**Rexroth**  
Bosch Group

© This document, as well as the data, specifications and other information set forth in it, are the exclusive property of Bosch Rexroth AG. It may not be reproduced or given to third parties without its consent.

The data specified above only serve to describe the product. No statements concerning a certain condition or suitability for a certain application can be derived from our information. The information given does not release the user from the obligation of own judgment and verification. It must be remembered that our products are subject to a natural process of wear and aging.