

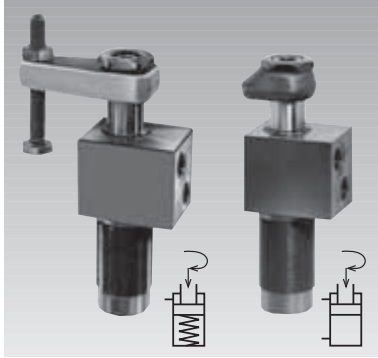

ROEMHELD

B 1.883

Swing Clamp with overload protection device, single and double acting max. operating pressure 500 bar



Application possibilities

These swing clamps are used when it is required to keep the fixture workpiece area free of straps and clamping components for unrestricted workpiece loading and unloading.

Function

This hydraulic clamping element is a pull-type cylinder, where a part of the total stroke is used to swing the piston (stroke to swing). The larger part of the stroke is available as clamping stroke.

General characteristics

Oil supply of this swing clamp is effected in the upper part of the housing. This allows to screw in or insert the swing clamps into fixture base plates if oil supply from below is not possible. By means of the required flange nut (see accessory) a certain height adjustment is possible.

Overload protection device

An integrated mechanical overload protection device prevents damage to the swing mechanism when striking an object within the 90° rotation; or in the case of inexpert mounting of the clamping arm.

Materials

By nitrating piston and housing, wear is reduced and protection against corrosion increased.

Piston material: High alloy steel
Cylinder body: Free-cutting steel

Note

If the possibility exists to draw liquid through this vent, a vent hose has to be installed. In principle, the double-acting version should be used in the case of such application conditions or cycle-dependant fixtures. Operating conditions, tolerances and other data see data sheet A 0.100.

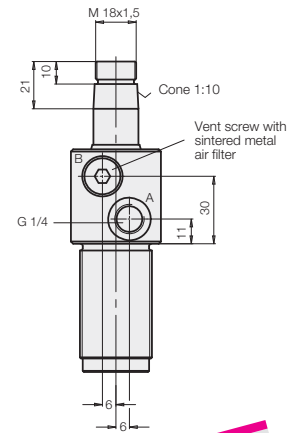
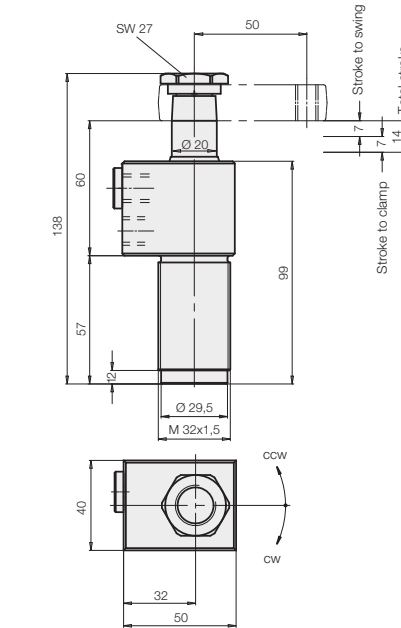

VITON® wiper standard

Angle of rotation	Direction	Single acting Part-no.	Double acting Part-no.
90°	cw	1882-101	1892-101
90°	ccw	1882-201	1892-201
60°	cw	1882-121	1892-121
60°	ccw	1882-221	1892-221
45°	cw	1882-131	1892-131
45°	ccw	1882-231	1892-231
0°	-	1882-241	1892-241

Standard angles of rotation are 45°, 60°, and 90° ±2°.

Special angles on request.

Other variants, as e.g. versions with metallic wiper on request.

Effective piston area	[cm ²]	1.01
Ratio of piston areas \diamond		4.1
Angle of rotation		90°
Stroke to swing	[mm]	7.0
Stroke to clamp	[mm]	7.0
Total stroke	[mm]	14.0
Oil volume/clamping stroke	[cm ³]	1.5
Oil volume/return stroke \diamond	[cm ³]	6.0
Max. oil flow rate*	[cm ³ /s]	1.5
Min. operating pressure for swing motion	[bar]	100
Min. operating pressure for swing motion \diamond	[bar]	50

\diamond only for double-acting version

* The maximum oil flow rate is valid for vertical mounting position in connection with standard clamping areas. If other mounting positions and/or other clamping areas are used, the oil flow rate is to be reduced, if necessary.

A possibly required flow control **has to be** made by flow control valves in the clamping line as well as in the unclamping line (stroke/return stroke).

Installation examples

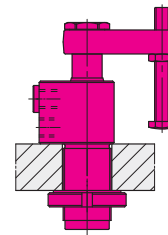
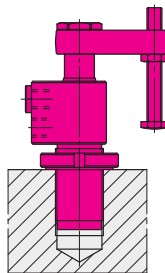

Accessories and clamping force diagram see page 2



ROEMHELD

Accessories

Clamping arm

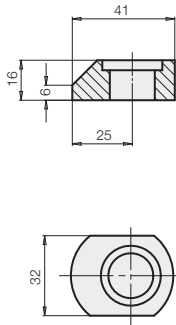

Part-no. **3548-159**

Clamping arm, complete

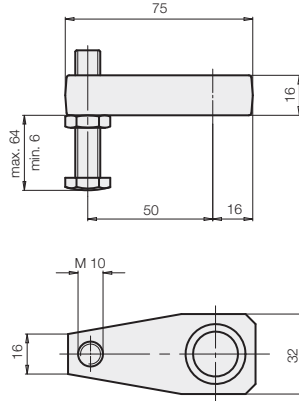

Part-no. **0354-001**
Part-no. **3921-016**
(without thread M 10)

Connecting dimensions for special clamping arm

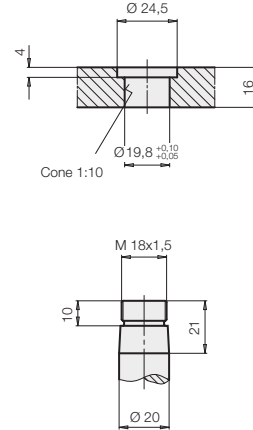

Effective clamping force in dependence of operating pressure p

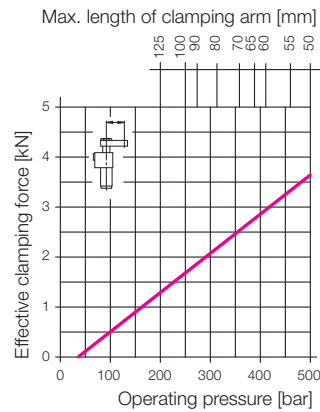
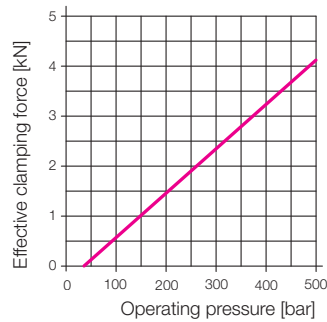

Flange nut DIN 1804

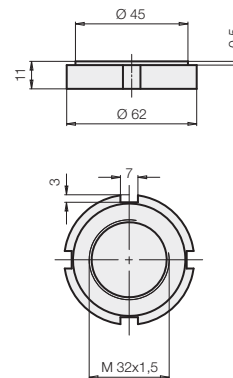

Part-no. **3301-019**