

Electric Drives
and Controls

Hydraulics

Linear Motion and
Assembly Technologies

Pneumatics

Service

Rexroth
Bosch Group

Directional servo-valve in 4-way version

RE 29621/03.12
Replaces: 05.09

1/14

Type 4WSE3E 25

Size 25
Component series 3X
Maximum operating pressure 350 bar
Maximum flow 1020 l/min

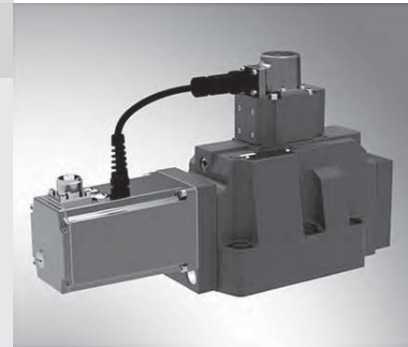

Table of contents

Contents	Page
Features	1
Ordering code	2
Symbol	2
Function, section	3
Technical data	4 to 6
Block diagram of the integrated electronics (OBE)	7
Characteristic curves	8 to 11
Unit dimensions	12
Flushing plate with porting pattern according to ISO 4401	13
Accessories	14

Features

- Valve for position, force, pressure or velocity control
- 3-stage servo-valve with electrical position control of the control spool of the 3rd stage, position sensing of the control spool by means of an inductive position transducer
- High dynamics 2-stage pilot control valve of size 6
- 1st stage as nozzle flapper plate amplifier
- Filter for 1st stage externally accessible and replaceable
- Subplate mounting:
Porting pattern according to ISO 4401
- Can also be used as 3-way version
- Valve and integrated control electronics are adjusted and tested in the factory
- Optimized valve control loop
- High response sensitivity, very low hysteresis and zero point drift
- Internal or external pilot oil supply and return
- Gap seals at pressure chambers of the control sleeve, no wear of O-ring

Ordering code

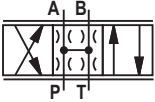
3-stage servo-valve		4WSE3E 25		3X		K31		*	
Size Size 25 = 25		Control spool symbol ¹⁾		Control spool position in de-energized state Not defined = no code 100 % P → A / B → T = P		Rated flow ²⁾		Control spool overlap ³⁾	
		= V = V1		= no code = P		210 l/min = 200 300 l/min = 300 380 l/min = 400 450 l/min = 500		0 to 0.5 % positive = D 0 to 0.5 % negative = E	
Component series 30 to 39 (30 to 39: Unchanged installation and connection dimensions)		= 3X		Seal material ⁴⁾		FKM seals = V NBR seals = M		Further details in the plain text	
Electronics interface command/actual value		A1 = 0 to 10 V C1 = 0 to 10 mA F1* = 4 to 20 mA		Electrical connection		K31 = 6+PE Without mating connector		Supply voltage	
15 = ±15 V 24 = +24 V		See page 6		Pressure rating ⁶⁾		7 = 210 bar 9 = 315 bar		Pilot flow ⁵⁾	
XY = Pilot oil supply external, return external XT = Pilot oil supply external, return internal PY = Pilot oil supply internal, return external PT = Pilot oil supply internal, return internal		* Only with +24 V supply voltage							

1) Control spool symbols

with control spool symbol V
P → A; $q_{V \max}$ B → T; $q_{V \max}$
P → B; $q_{V \max}$ A → T; $q_{V \max}$
with control spool symbol V1
P → A; $q_{V \max}$ B → T; $q_V / 2$
P → B; $q_V / 2$ A → T; $q_{V \max}$

2) Rated flow

The rated flow refers to a 100 % command value signal at 70 bar valve pressure differential (35 bar per control edge). The valve pressure differential must be regarded as reference. Other values result in the flow being changed. A possible rated flow tolerance of ±10 % and a saturation influence must be taken into account (see flow/signal function page 8).

3) Control spool overlap

The control spool overlap in % is referred to the nominal stroke of the control spool.
(Other control spool overlaps upon request.)

4) Seal material

See notice on page 5

5) Pilot oil

Care should be taken that the pilot pressure is as constant as possible. An external pilot control via port X is thus often advantageous.

6) Inlet pressure range

Care should be taken that the inlet pressure is as constant as possible. Minimum pilot pressure ≥ 10 bar.
Up to a pilot pressure of 210 bar, pressure rating 7 is to be selected. From a pilot pressure greater than 210 bar, pressure rating 9 is to be selected.
With regard to the dynamics, the frequency response dependency must be observed within the admissible pressure range. At an inlet pressure > 40 bar, the pilot pressure must not be less than 60 % of the inlet pressure as otherwise the current forces at the control spool of the 3rd stage will impair the controllability.
At an inlet pressure ≤ 40 bar, working with a pilot pressure above port X (external supply) is in any case advantageous.

Symbol

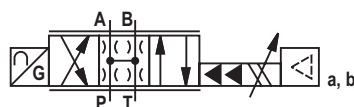

Function, section

Valves of type 4WSE3E 25 are electrically operated, 3-stage directional servo-valves. They are mainly used for position, force or pressure and velocity controls.

These valves consist of a 2-stage pilot control valve of type 4WS2EM 6 (1), a main stage with a main control spool in a sleeve (2), an inductive position transducer (3), and integrated control electronics (4).

The pilot control valve (1) consists of an electro-mechanical transformer (torque motor), a hydraulic amplifier (nozzle flapper plate principle) and a pilot control spool in a sleeve, which is connected to the torque motor via a mechanical feedback.

Electric currents in the coils of the torque motor generate a force by means of a permanent magnet which acts on the armature, and in connection with a torque tube results in a torque. This causes the flapper plate which is connected to the torque tube via a pin to move from the central position between the two control nozzles, and a pressure differential is created across the front sides of the pilot control spool. The pressure differential results in the control spool changing its position, which results in the pressure port being connected to one actuator port and, at the same time, the other actuator port being connected to the return flow port.

The pilot control spool is connected to the flapper plate or the torque motor by means of a bending spring (mechanical feedback).

The position of the control spool is changed until the flapper plate position and hence the pressure differential across the nozzle flapper plate system becomes zero due to the feedback torque, which acts via the bending spring against the electro-magnetic torque of the torque motor.

In doing so, the stroke of the pilot control spool and hence the flow of the pilot control valve is controlled proportionally to the electrical input signal (see data sheet 29564).

In the main stage, the main control spool (2) is operated by the pilot control valve and its position is sensed by an inductive position transducer (3). The position transducer signal is compared to the command value by integrated control electronics (4). Any possible control deviation is amplified electrically and fed to the pilot control valve as control signal. The pilot control valve starts to move and the main control spool is re-positioned.

The stroke of the main control spool and consequently the flow of the servo-valve are controlled in proportion to the command value. It must be noted that the flow depends on the valve pressure differential.

The valve zero point can be adjusted by means of an externally accessible potentiometer.

The valves are factory-set with a dither default setting with the constant frequency of 400 Hz.

Notice!

Changes in the zero point and/or the dither amplitude may result in damage to the system and may only be implemented by instructed specialists.

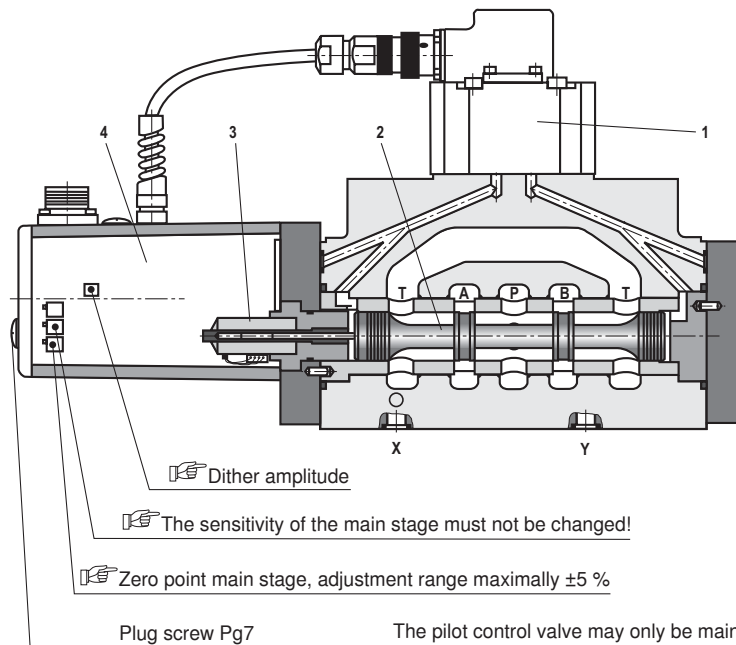

The pilot control valve may only be maintained by Bosch Rexroth employees. An exception to this is the replacement of the filter element – see data sheet 29564.

Technical data (For applications outside these parameters, please consult us!)

general

Weight	kg	16
Installation position		Any, if it is ensured that the pilot control is supplied with sufficient pressure (> 10 bar) during start-up of the system. In case of insufficient pressure supply, the control spool of the servo-valve can take any position. This may result in channel P being connected to the actuator and the build-up of pressure being delayed. This may be prevented by providing an external pressure supply at port X.
Storage temperature range	°C	-20 to +80
Ambient temperature range	°C	-20 to +60

hydraulic (measured with HLP 32, $\vartheta_{oil} = 40 \text{ °C} \pm 5 \text{ °C}$)

Maximum operating pressure	Pilot control stage, pilot oil supply X	bar	10 to 210 and/or 10 to 315 (see page 2, pressure rating)
	Main valve, port P, A, B Pilot oil supply internal	bar	315
	Main valve, port P, A, B Pilot oil supply external	bar	350
Maximum return flow pressure	Pilot control stage, port Y	bar	Pressure peaks < 100 admissible, static < 10
	Main valve, port T Pilot oil return internal	bar	Pressure peaks < 100 admissible, static < 10
	Main valve, port T Pilot oil return external	bar	250
Leakage flow			See page 9 (characteristic curves)
Rated flow $q_{Vnom} \pm 10 \%$ with $\Delta p = 70 \text{ bar}$		l/min	210, 300, 380, 450
Hydraulic fluid			See table page 5
Hydraulic fluid temperature range		°C	-20 to +80; preferably +40 to +50
Viscosity range		mm ² /s	15 to 380; preferably 30 to 45
Maximum admissible degree of contamination of the hydraulic fluid cleanliness class according to ISO 4406 (c)	Pilot control valve		Class 18/16/13 ¹⁾
	Main stage		Class 20/18/15 ¹⁾
Hysteresis		%	≤ 0.10
Range of inversion		%	≤ 0.05
Response sensitivity		%	≤ 0.05
Pressure gain			≥ 90 % of p_p ²⁾ with 1 % change in the control spool stroke (from hydraulic zero point)
Zero shift upon change of:	Hydraulic fluid temperature	% / 10 K	≤ 0.3
	Ambient temperature	% / 10 K	≤ 0.3
	Operating pressure	% / 100 bar	≤ 0.3
	Return flow pressure 0 to 10 % of p_p	% / 100 bar	≤ 0.3

¹⁾ The cleanliness classes specified for the components must be adhered to in hydraulic systems. Effective filtration prevents faults and at the same time increases the service life of the components.
For the selection of the filters see www.boschrexroth.com/filter

²⁾ p_p = Inlet pressure/operating pressure

🔧 Notice!

For information on the **environment simulation testing** for the areas EMC (electromagnetic compatibility), climate and mechanical load, see data sheet 29620-U.

Technical data (For applications outside these parameters, please consult us!)

Hydraulic fluid	Classification	Suitable sealing materials	Standards
Mineral oils and related hydrocarbons	HL, HLP	NBR, FKM	DIN 51524
Flame-resistant – containing water	HFC Fuchs Hydrotherm 46M Petrofer Ultra Safe 620	NBR	ISO 12922

Important information on hydraulic fluids!

- For more information and data on the use of other hydraulic fluids refer to data sheet 90220 or contact us!
- There may be limitations regarding the technical valve data (temperature, pressure range, service life, maintenance intervals, etc.)!

– Flame-resistant – containing water:

Maximum pressure differential per control edge 210 bar, otherwise, increased cavitation erosion!
Tank pre-loading < 1 bar or > 20 % of the pressure differential of the tank edge. The pressure peaks should not exceed the maximum operating pressures!
Maximum fluid temperature 60 °C

Technical data (For applications outside these parameters, please consult us!)

electric

Protection class according to EN 60529	IP 65 with mating connector mounted and locked
Type of signal	Analog

Electronics interface	A1	C1	F1	
Pin				
Current consumption at the mating connector	A	< ±150 mA with ±15 V < 200 mA with 24 V		
	B			
	D	0 to ±0.05 mA	0 to ±10 mA	4 to 20 mA
	E			

Device connector allocation	Pin	Supply voltage 15		Supply voltage 24		
		A1	C1	A1	C1	F1
Interface						
Supply voltage	A	+15 VDC		+24 VDC		
	B	-15 VDC		0 VDC		
M0	C	0 VDC / reference to pins A, B		Not used		
Differential command value input	D	0 to ±10 V	0 to ±10 mA	0 to ±10 V	0 to ±10 mA	4 to 20 mA
	E	$R_e > 100 \text{ k}\Omega$	$R_e = 100 \Omega$	$R_e > 100 \text{ k}\Omega$	$R_e = 100 \Omega$	$R_e = 100 \Omega$
Actual value						
Reference with +24 V is pin B	F	0 to ±10 V	0 to ±10 mA	0 to ±10 V	0 to ±10 mA	4 to 20 mA
Reference with ±15 V is pin C		$R_i \approx 1 \text{ k}\Omega$	Load max. 1 kΩ	$R_i \approx 1 \text{ k}\Omega$	Load max. 1 kΩ	Load max. 500 Ω
Protective earth	PE	Connected to valve housing				

 **One end of the shield must be connected to the control!**

Supply voltage: ±15 V ±3 %, residual ripple < 1 %
+24 VDC / 18 V to 35 V; full bridge rectification with smoothing capacitor
2200 µF = $I_{\max} = 230 \text{ mA}$

Command value: **A1, C1:**
Reference potential at E and positive command value at D result in flow from P → A and B → T.
Reference potential at E and negative command value at D result in flow from P → B and A → T.

F1:
Reference potential at E and signal 12 to 20 mA at D result in flow from P → A and B → T.
Reference potential at E and signal 12 to 4 mA at D result in flow from P → B and A → T.

Actual value / measuring output: The voltage / current signal is proportional to the control spool stroke and has the same sign as the command value.

Connection cable: Recommendation: – up to 25 m line length: Type LiYCY 7 x 0.75 mm²
– up to 50 m line length: Type LiYCY 7 x 1.0 mm²
Only connect the shield to ⊥ on the supply side.

Notice: **Electric signals taken out via valve electronics (e.g. actual value) must not be used for switching off safety-relevant machine functions!**

Block diagram of the integrated electronics (OBE)

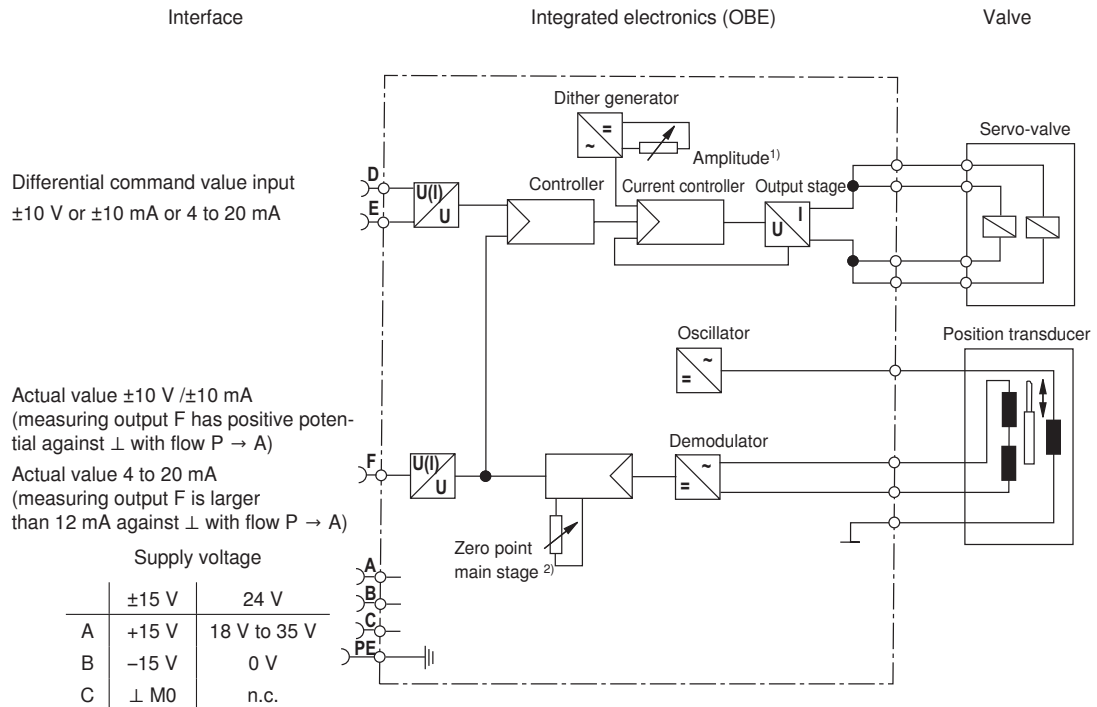

1) 2)

Changes in the zero point and/or the dither amplitude may result in damage to the system and may only be implemented by instructed specialists.

Characteristic curves (measured with HLP46, $\vartheta_{oil} = 40 \text{ }^\circ\text{C} \pm 5 \text{ }^\circ\text{C}$)

Flow/load function (tolerance $\pm 10 \%$) with 100 % command value signal

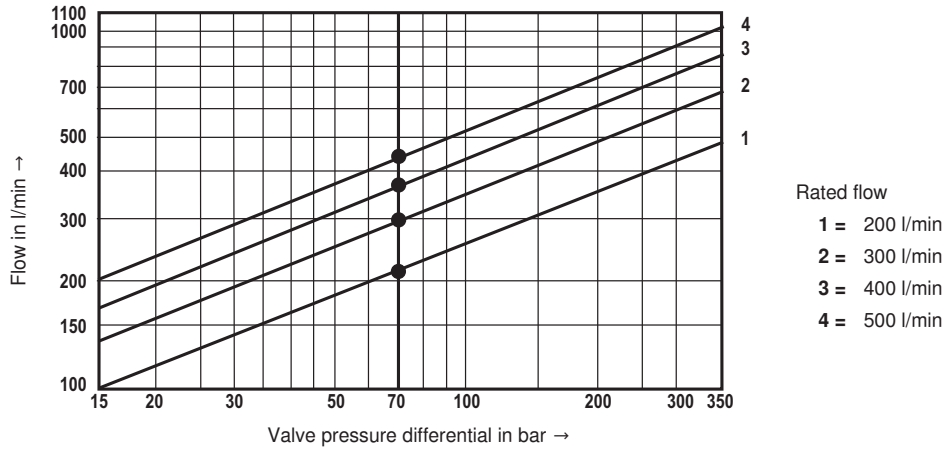

Δp = Valve pressure differential (inlet pressure p_p minus load pressure p_L minus return flow pressure p_T)

Tolerance field of the flow/signal function at constant valve pressure differential

Summated edge $\Delta p_V = 70$ bar

Single edge $\Delta p_V = 35$ bar (tolerance $\pm 5 \%$)

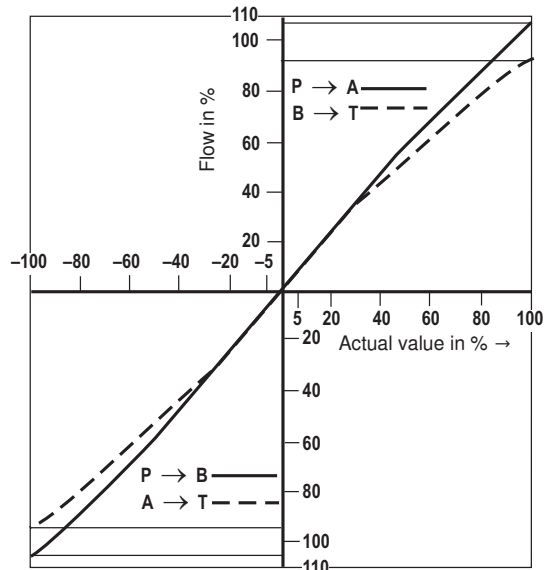
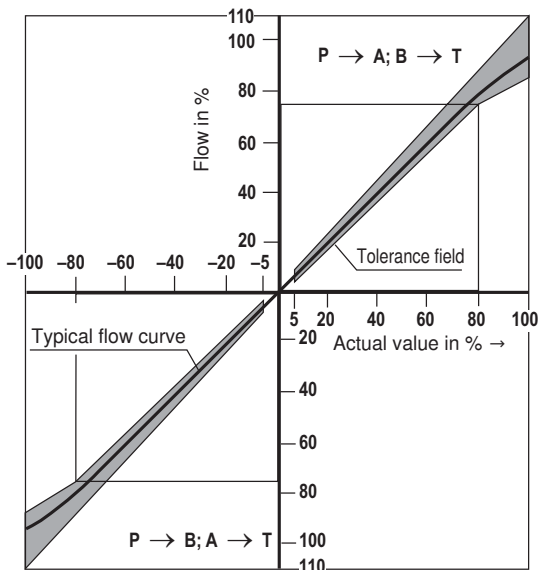

* With interface F1, the negative command value axis corresponds to 4 to 12 mA, the positive command value axis to 12 to 20 mA

Characteristic curves (measured with HLP32, $\vartheta_{oil} = 40 \text{ }^\circ\text{C} \pm 5 \text{ }^\circ\text{C}$)

Pressure signal characteristic curve

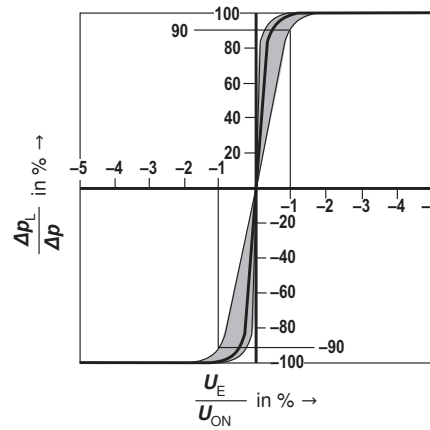

Measured at
280 bar operating pressure

Zero flow total with "D" overlap (pilot control valve and main stage)

Tolerance $\pm 20 \%$

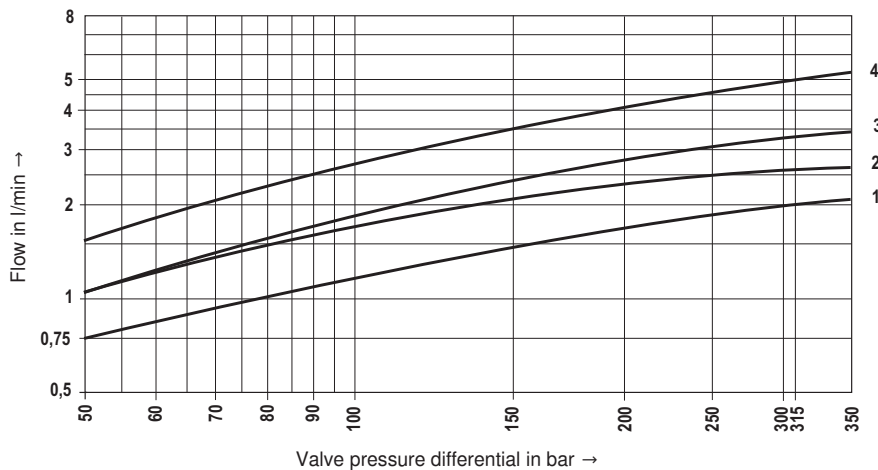

1 = 200 l/min
2 = 300 l/min
3 = 400 l/min
4 = 500 l/min

Zero flow Data valid for overlap "E"	Pilot control valve L1	l/min	$\leq \sqrt{\frac{p_p}{70 \text{ bar}}} \cdot 0.55$
	Overall valve q_v	l/min	$\leq \sqrt{\frac{p_p}{70 \text{ bar}}} \cdot 0.015 \cdot q_{Vnom}$

q_{Vnom} Rated flow (overall valve) in l/min
210, 300, 380, 450

p_p Operating pressure in bar

Δp Valve pressure differential in bar

q_v 200, 300, 400, 500 l/min

Characteristic curves (measured with HLP32, $\vartheta_{oil} = 40 \text{ }^\circ\text{C} \pm 5 \text{ }^\circ\text{C}$)

Transition function – measured with 210 bar pressure rating

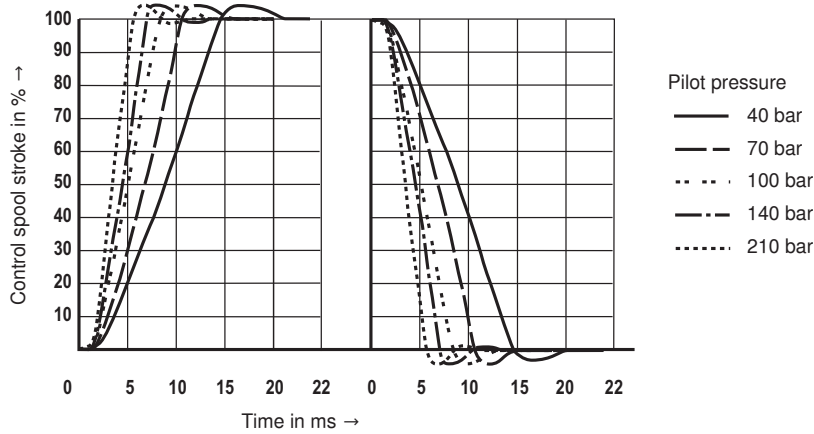

Frequency response at $p_p = 210 \text{ bar}$ – measured with 210 bar pressure rating

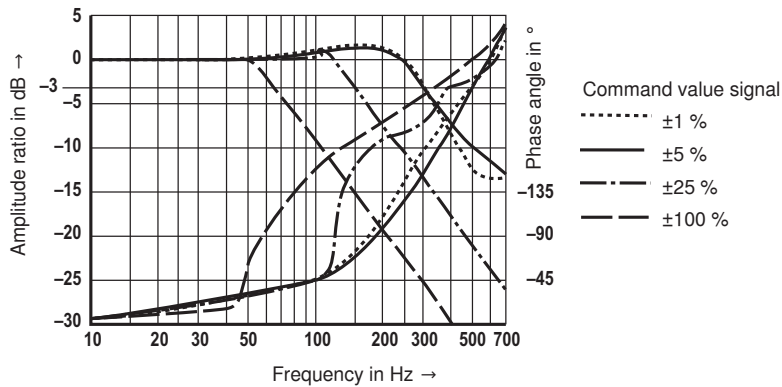

Dependence of the -90° frequency on the pilot pressure – measured with 210 bar pressure rating

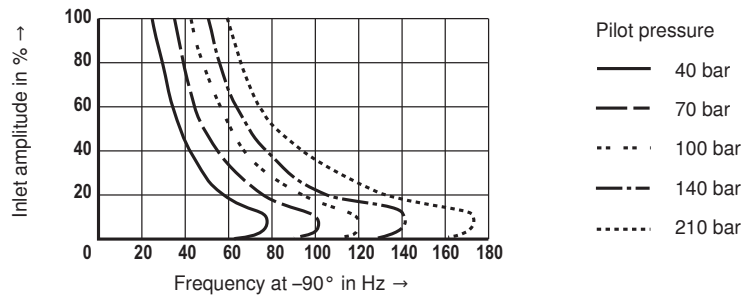

Characteristic curves (measured with HLP32, $\bar{\nu}_{oil} = 40 \text{ }^\circ\text{C} \pm 5 \text{ }^\circ\text{C}$)

Transition function – measured with 315 bar pressure rating

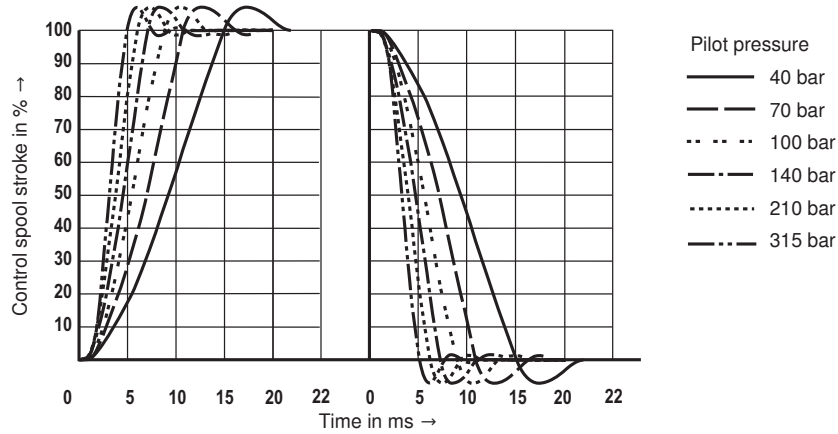

Frequency response at $p_p = 315 \text{ bar}$ – measured with 315 bar pressure rating

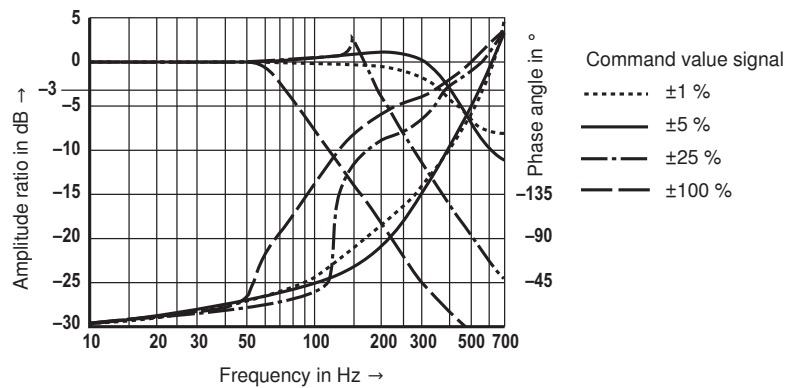

Dependence of the -90° frequency on the pilot pressure – measured with 315 bar pressure rating

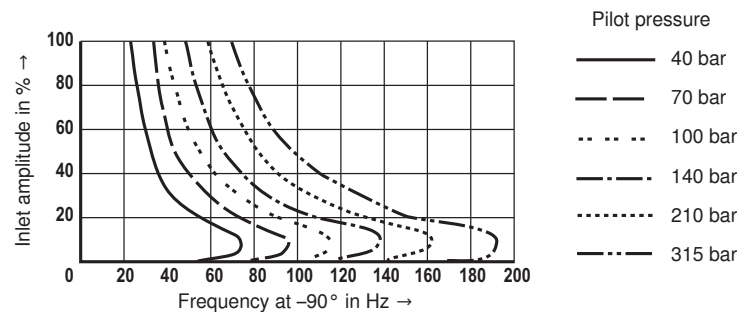

Unit dimensions: Type 4WSE3E 25 (dimensions in mm)

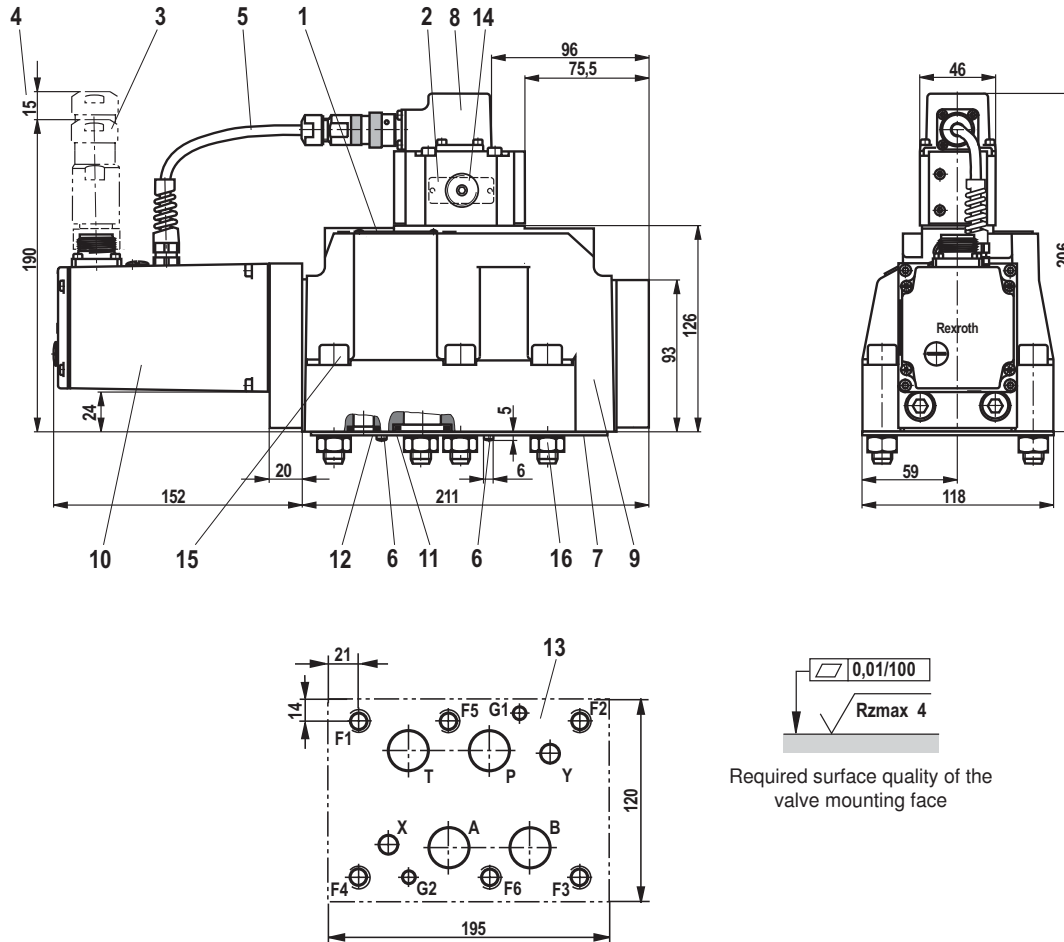

- | | |
|--|--|
| 1 Name plate – overall valve | 10 Integrated control electronics |
| 2 Name plate – pilot control valve | 11 Identical seal rings for ports A, B, P, and T |
| 3 Mating connector according to EN 175201-804, separate order, see page 13 | 12 Identical seal rings for ports X and Y
The ports X and Y are also pressurized in the case of "internal" pilot oil supply |
| 4 Space required to remove the mating connector, take connection cable into account! | 13 Machined valve mounting face, porting pattern according to ISO 4401-08-08-0-05 |
| 5 PVC cable not resistant when in contact with HFD-R fluid | 14 Exchangeable filter element with seal, material no. R961000194 |
| 6 Locating pin (2 units) G1 and G2 | 15 Valve mounting screws |
| 7 Cover plate (for transport only) | 16 Hexagon nuts (for transport only) |
| 8 Pilot control valve (2-stage) | |
| 9 Main stage (3rd stage) | |

Hexagon socket head cap screws
(included in the scope of delivery)

		Material number
Size 25	6x ISO 4762 - M12 x 60 - 10.9-flZn-240h-L Tightening torque $M_A = 100 \text{ Nm} \pm 10 \%$	R913000121

Notice: The tightening torque of the hexagon socket head cap screws refers to the maximum operating pressure!

Flushing plate with porting pattern according to ISO 4401-08-08-0-05 (dimensions in mm)

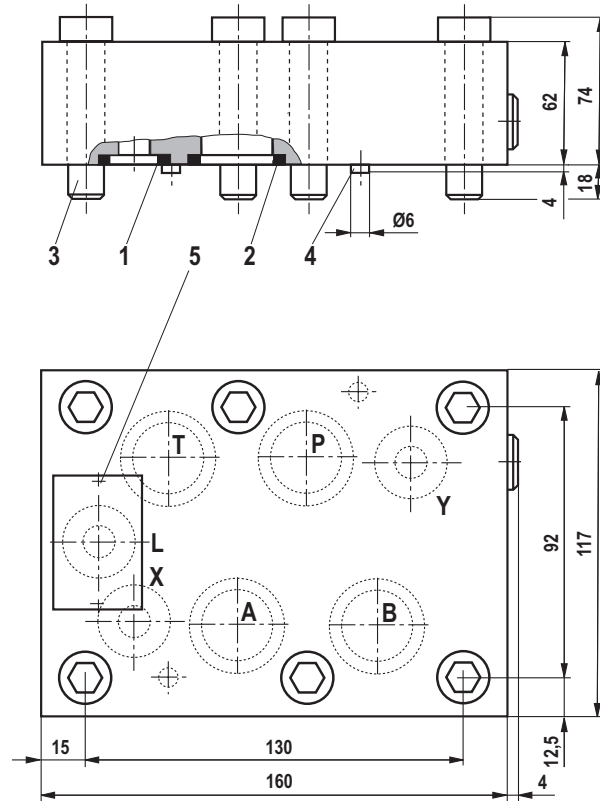

- 1 R-ring 19x3x3 (X, Y) included in scope of delivery
- 2 R-ring 27.8x2.6x3 (P, T, A, B) included in scope of delivery
- 3 6 hexagon socket head cap screws (included in scope of delivery)
ISO4762-M12x80-10.9
(friction coefficient 0.09 to 0.14 according to VDA 235-101)
 $M_A = 100 \text{ Nm}$
Material no. **R913000413**
- 4 2 locating pins ISO8741 - 6X12-ST
- 5 Name plate

To ensure proper functioning of the servo-valves, it is necessary to flush the system before commissioning. The following values are guidelines for the flushing time per system:

$$t \geq \frac{V}{q_v} \cdot 5$$

t = Flushing time in hours
 V = Tank capacity in liters
 q_v = Pump flow in liters per minute

When topping up more than 10 % of the tank capacity, the flushing procedure must be repeated.

The use of a directional valve with port in accordance with ISO 4401-08-08-0-05 is better suited than a flushing plate. With this valve, you can also flush the actuator ports.

Symbols

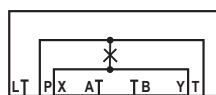

with FKM seals,
Material no. **R900959384**
Weight: 8.4 kg



with FKM seals,
Material no. **R900959377**
(without fig.)
Weight: 8.4 kg

Accessories (not included in the scope of delivery)

Mating connectors		Material number
Mating connector for servo-valve	DIN EN 175201-804, see data sheet 08006	R900223890 (metal)
Subplates		Data sheet
Size 25		45058

Notes

© This document, as well as the data, specifications and other information set forth in it, are the exclusive property of Bosch Rexroth AG. It may not be reproduced or given to third parties without its consent. The data specified above only serve to describe the product. No statements concerning a certain condition or suitability for a certain application can be derived from our information. The information given does not release the user from the obligation of own judgment and verification. It must be remembered that our products are subject to a natural process of wear and aging.