

Industrial
Hydraulics

Electric Drives
and Controls

Linear Motion and
Assembly Technologies

Pneumatics

Service
Automation

Mobile
Hydraulics

Rexroth
Bosch Group

RE 26 864/05.02

Replaces: 12.95

Pressure reducing valve, pilot operated, Type ZDRK 10 V

Nominal size 10

Series 1X

Maximum operating pressure 210 bar

Maximum flow 80 L/min

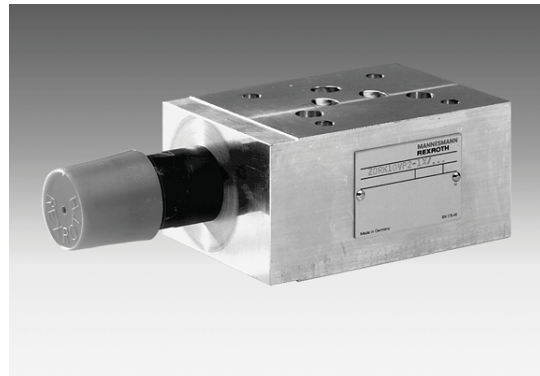

H/A 4085/94

Type ZDRK 10 VP5-1X/...

Overview of contents

Contents	Page
Features	1
Ordering details, symbols	2
Preferred types	2
Function, section	3
Technical data	3
Characteristic curves	4
Unit dimensions	5, 6

Features

- Sandwich plate valve
- Porting pattern to DIN 24 340 form A, ISO 4401 and CETOP-RP 121 H
- 3 pressure stages
- Pressure reduction in ports A2, B2 or P1
- Check valve with versions „VA“ and „VB“
- Pressure gauge connection port
- Adjustment element: Sleeve with hexagon and protective cap



© 2002

by Bosch Rexroth AG, Industrial Hydraulics, D-97813 Lohr am Main

All rights reserved. No part of this document may be reproduced or stored, processed, duplicated or circulated using electronic systems, in any form or by any means, without the prior written authorisation of Bosch Rexroth AG. In the event of contravention of the above provisions, the contravening party is obliged to pay compensation.

This document was prepared with the greatest of care, and all statements have been examined for correctness.

This document is subject to alterations for reason of the continuing further developments of products.

No liability can be accepted for any incorrect or incomplete statements.

Ordering details, symbols (① = component side, ② = subplate side)

Symbol	Pressure reduction	Secondary pressure in bar	Setting elements	Material No.	Type description
	In port A2	50		00564546	ZDRK 10 VA5-1X/50YV
		100		00595461	ZDRK 10 VA5-1X/100YV
		210		00564547	ZDRK 10 VA5-1X/210YV
	In port B2	50		00564548	ZDRK 10 VB5-1X/50YV
		100		00564549	ZDRK 10 VB5-1X/100YV
		210		00564550	ZDRK 10 VB5-1X/210YV
	In port P1	50		00564551	ZDRK 10 VP5-1X/50YMV
		100		00564552	ZDRK 10 VP5-1X/100YMV
		210		00564553	ZDRK 10 VP5-1X/210YMV

Preferred types (readily available)

Type	Material No.
ZDRK 10 VP5-1X/100YMV	00564552
ZDRK 10 VP5-1X/210YMK	00564553

Preferred types and standard components are highlighted in the RPS (Standard Price list).

Function, section

ZDRK 10V pressure valves are pilot operated 3-way pressure reducing valves of sandwich plate design with a pressure relief function for the secondary circuit. They are used to reduce the pressure in a hydraulic system.

The pressure reducing valves mainly consist of cartridge (1) and housing (2). The setting of the secondary pressure is via the adjustment element (4).

Version „VP“

At rest the valves are open; pressure fluid can flow unrestricted from port P2 to port P1. The pressure in port P1 is applied simultaneously to the main spool (6) and via the bore (5) to the spring loaded internal area of the main spool (6). It is also applied to the pilot poppet (8) via the orifice (9). If the pressure in port P1 rises above the value set at the compression spring (7) the pilot poppet (8) opens. Pressure fluid flows from the spring loaded internal area of the main spool (6) via the orifice (9) and the pilot poppet (8) into the spring chamber (10). The main spool (6) moves into the control position and keeps the value in channel P1 set at the compression spring (7) constant.

If the pressure in port P1 continues to rise due to external forces at the actuator, the main spool (6) moves still further against the compression spring (7).

Thus port P1 is connected to the tank (port TA) via the control edge at the main spool and housing. Enough pressure fluid flows into the tank to ensure that the pressure does not continue to rise. The pilot oil return from the spring chamber (10) is via port TA.

A pressure gauge connection port (3) enables the control of the secondary pressure at the valve.

Versions „VA“ and „VB“

In versions VA and VB the pressure reduction is in port A2 / B2.

For free return flow from port A2 to A1 / B2 to B1 a check valve is installed. (Not possible for version VP).

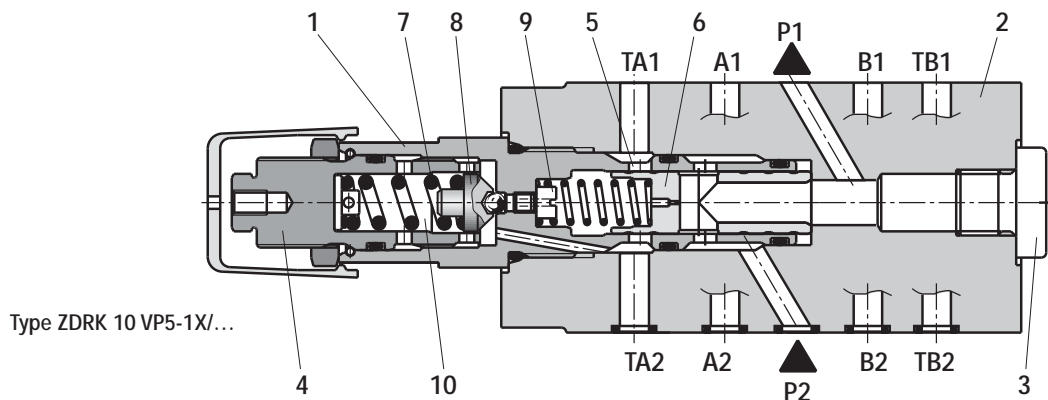

Type ZDRK 10 VP5-1X/...

Technical data (for applications outside these parameters, please consult us!)

General

Installation		Optional
Ambient temperature range	°C	-20 to +80
Weight	Versions VA and VB	kg
	Version VP	kg
		Approx. 1.5
		Approx. 1.1

Hydraulic

Maximum inlet pressure (inlet)	bar	210
Maximum secondary pressure (ports A2, B2 or P1)	bar	50; 100; 210
Maximum back pressure (ports TA, TB)	bar	160
Maximum flow	L/min	80
Pressure fluid		Mineral oil (HL, HLP) to DIN 51 524; Fast bio-degradable pressure fluids to VDMA 24 568 (also see RE 90 221); HETG (rape seed oil); HEPG (polyglycols); HEES (synthetic ester); other pressure fluids on request
Pressure fluid temperature range	°C	-20 to +80
Viscosity range	mm ² /s	10 to 800
Degree of contamination		Maximum permissible degree of contamination of the pressure fluid is to NAS 1638 class 9. We therefore recommend a filter with a minimum retention rate of $\beta_{10} \geq 75$

Characteristic curves (measured with HLP46, $\vartheta_{oil} = 40\text{ °C} \pm 5\text{ °C}$)

Versions VA and VB

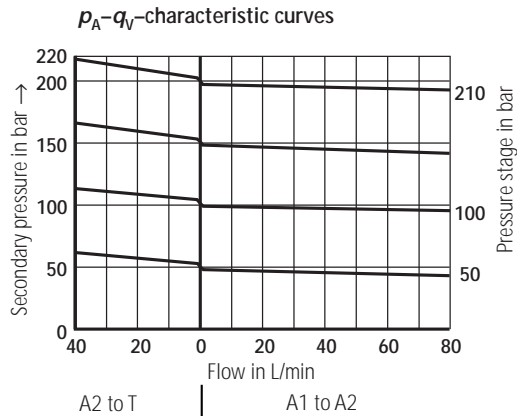

Version VP

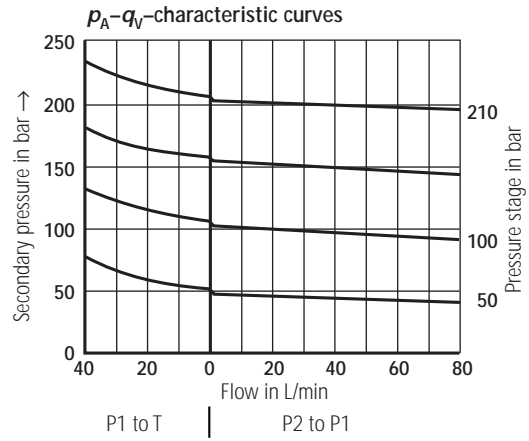

⚠ Attention! The curve characteristics are maintained at lower set pressure in relation to the pressure stage.

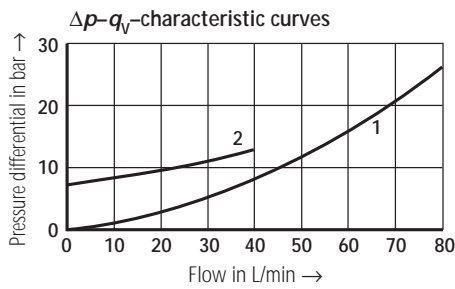

- 1 A1 to A2
- 2 A2 to T (3. way)

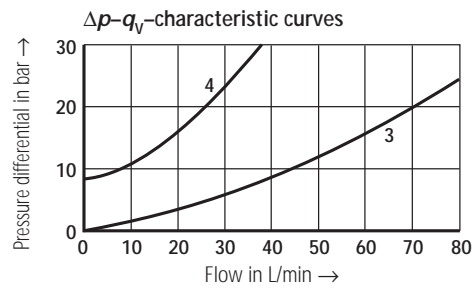

- 3 P2 to P1
- 4 P1 to T (3. way)

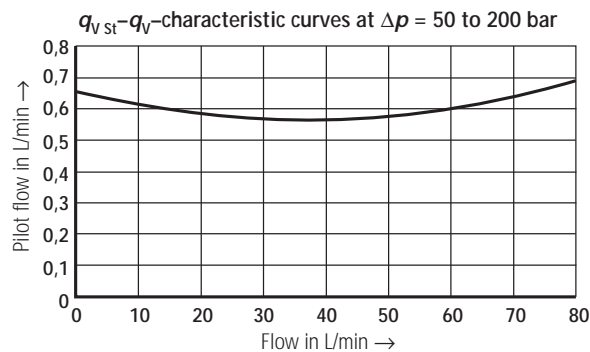

The characteristic curves for the pressure reducing function are valid for an output pressure = zero in the entire flow range!

Unit dimensions: versions VA and VB (dimensions in mm)

Type ZDRK 10 VA

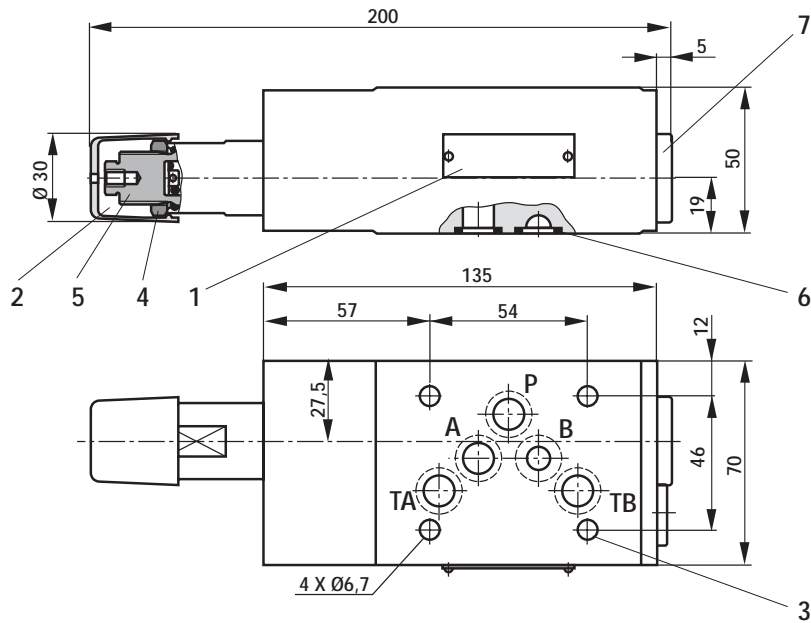

Type ZDRK 10 VB

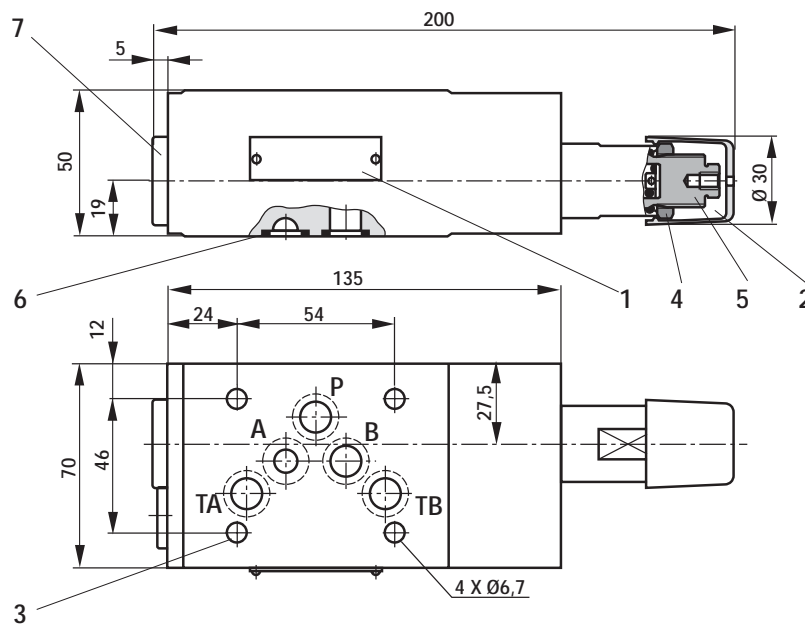

- 1 Name plate
- 2 Adjustment element (sleeve with hexagon and protective cap)
- 3 Valve fixing holes
- 4 Locknut 24A/F
- 5 Hexagon 10A/F
- 6 Same seal rings for ports A2, B2, P2, TA2, TB2

- 7 Pressure gauge connection G 1/4; 12 deep; internal hexagon 6A/F

Valve fixing screws

M6 DIN 912-10.9,
Tightening torque $M_A = 15.5 \text{ Nm}$,
must be ordered separately

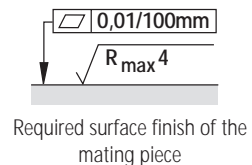

Unit dimensions: version VP (dimensions in mm)

Type ZDRK 10 VP

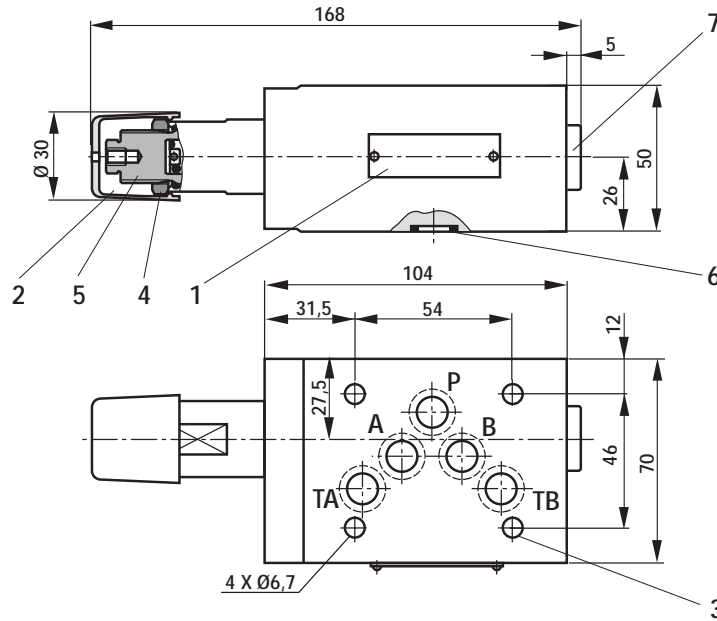

- 1 Name plate
- 2 Adjustment element (sleeve with hexagon and protective cap)
- 3 Valve fixing holes
- 4 Locknut 24A/F
- 5 Hexagon 10A/F
- 6 Same seal rings for ports A2, B2, P2, TA2, TB2

- 7 Pressure gauge connection G 1/4; 12 deep; internal hexagon 6A/F

Valve fixing screws
M6 DIN 912-10.9,
Tightening torque $M_A = 15.5 \text{ Nm}$,
must be ordered separately

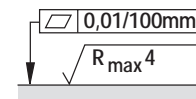

Required surface finish of the mating piece

The data specified above only serve to describe the product. No statements concerning a certain condition or suitability for a certain application can be derived from our information. It must be remembered that our products are subject to a natural process of wear and ageing.