

## Posi Lock® 100 Ton Hydraulic Grip Pullers

▼ EPH-1003E



- Roller cart with power lift
- Hydraulically actuated lift cylinder on cart extends puller from ground to a height of 1,7 m
- Adjustable jaw tips
- Includes electric one stage pump with remote pendant for fingertip control of the removal process
- Puller height range 673 to 1690 mm
- Multiple pushing adaptors included.



◀ The EPH-1002E quickly and easily removes this drive coupler from its shaft.

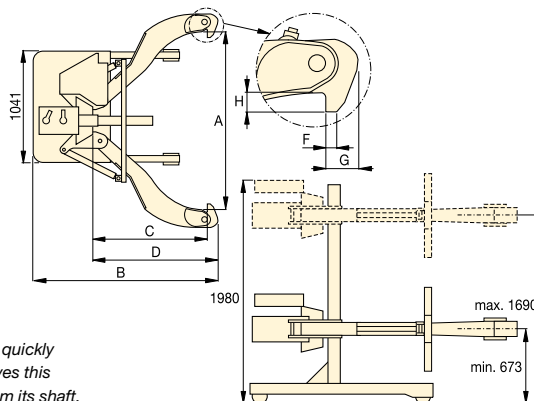

### EPH Series



Capacity:  
**100 ton**

Maximum Reach:  
**1219 mm**

Spread Range:  
**190 - 1778 mm**

Maximum Operating Pressure:  
**700 bar**



#### Pushing Adaptors

All Posi Lock® 100 Ton Hydraulic Pullers include following pushing adaptors.

Diameter (mm)	Length (mm)	Model Number
89	737	EPHT-1162
89	483	EPHT-1163
89	229	EPHT-1164

Number of Jaws	Spread Range A (mm)	Capacity ton (kN)	Model Number	Cylinder Stroke (mm)	Overall Length B (mm)	Reach C (mm)	Jaw Length D (mm)	Jaw Width F (mm)	Tip Clearance G (mm)	Tip Depth H (mm)	Weight (kg)
2	190 - 1778	100 (980)	EPH-1002E	250	1955	1219	1346	32	89	89	771
3	190 - 1778	100 (980)	EPH-1003E	250	1955	1219	1346	32	89	89	907