

Electric Drives
and Controls

Hydraulics

Linear Motion and
Assembly Technologies

Pneumatics

Service

Rexroth
Bosch Group

3-way flow control valve

RE 28862/08.08
Replaces: 04.81

1/8

Type 3FRM

Sizes 10 and 16
Component series 2X
Maximum operating pressure 315 bar
Maximum flow 160 l/min



Table of contents

Content

Features
Ordering code
Symbols
Function, section
Technical data
Characteristic curves
Unit dimensions

Page

– For subplate mounting
1 – Mechanical actuation
2 – Pressure relief valve (overload protection), optional
2 – Reduction of the start-up jump
3 – Unloading port for free circulation, optional
4
5
6

Features

Ordering code

3FRM		M	-2X/				*
3-way flow control valve							
Mechanical actuation		= M					
Size 10		= 10					
Size 16		= 16					
Component series 20 to 29 (20 to 29: unchanged installation and connection dimensions)		= 2X					
Further details in clear text							
Flow range from A to B							
NG10, linear							
Up to 10 l/min		= 10L					
Up to 16 l/min		= 16L					
Up to 25 l/min		= 25L					
Up to 50 l/min		= 50L					
NG16, linear							
Up to 60 l/min		= 60L					
Up to 100 l/min		= 100L					
Up to 160 l/min		= 160L					
Seal material							
No code =							NBR seals
V =							FKM seals (other seals on request)
							⚠ Attention! Observe compatibility of seals with hydraulic fluid used!
Without unloading port							
X =							With unloading port
Without pressure relief valve							
D =							With pressure relief valve

Standard types and components are shown in the EPS (standard price list).

Symbols

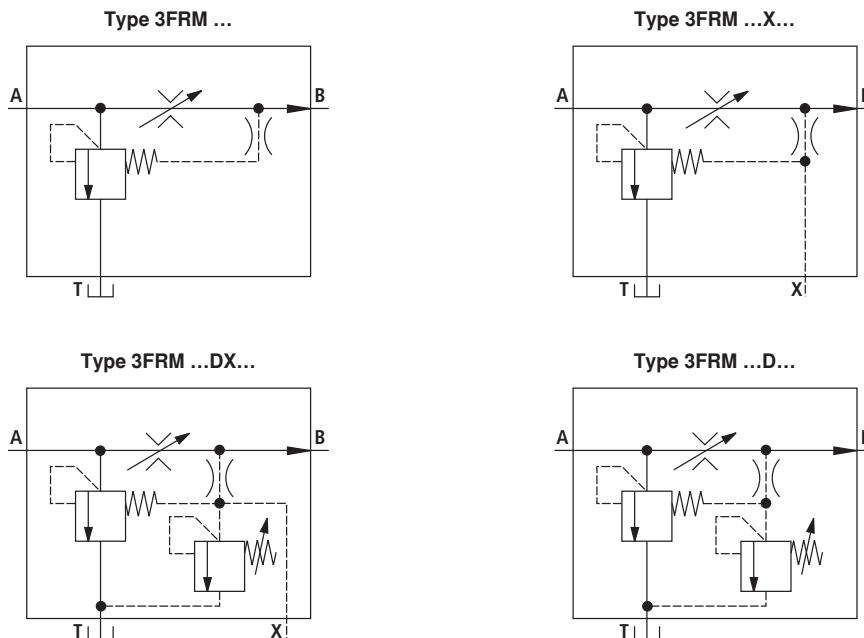

Function, section

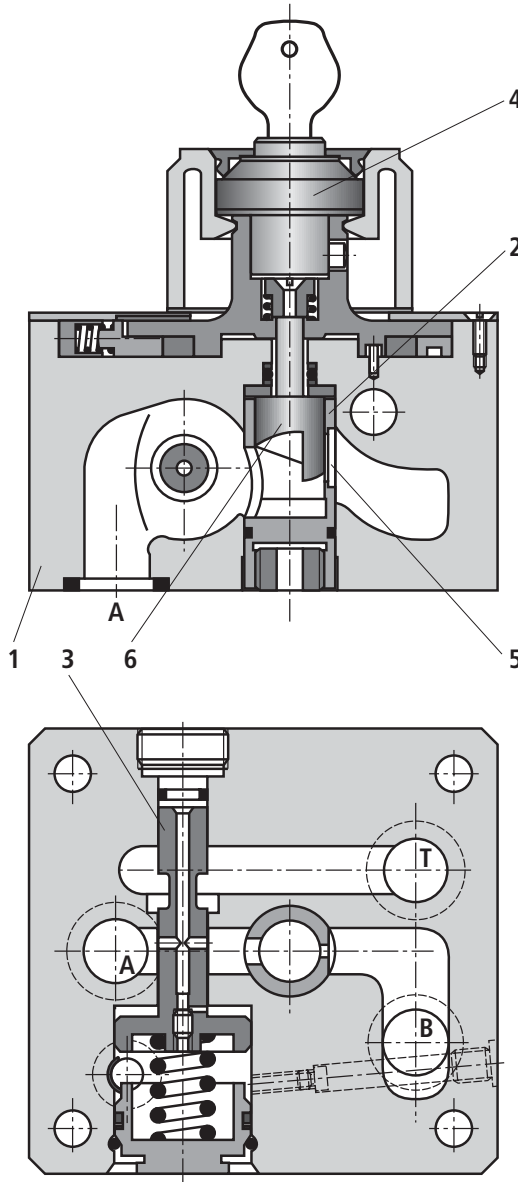

Flow control valves of type 3FRM are 3-way flow control valves. They keep a set flow constant independently of pressure and temperature fluctuations.

The valves basically consist of housing (1), orifice bushing (2), pressure compensator (3) and adjustment element (4).

The flow from channel A to B is throttled at throttling point (5). The throttle cross-section is adjusted by turning curved pin (6) mechanically by means of adjustment element (4). To keep the flow constant at throttling point (5) a pressure compensator (3) is connected upstream.

The pressure compensator discharges the excessive flow via an additional line to the tank. For this reason, these valves may only be used in the supply line!

On 3-way flow control valves (contrary to 2-way flow control valves) the metering and control orifices are not connected in series, but in parallel.

The independence on temperature results from the design of the throttling point of the orifice.

The working pressure of the hydraulic pump is only by the amount of the pressure differential across the metering orifice greater than the actuator pressure, whereas with a 2-way flow control valve, the hydraulic pump must always generate the pressure set on the pressure relief valve. The 3-way flow control valve therefore features lower line losses and thus offers a more favorable system efficiency while generating less heat.

Flow control valves are optionally available with or without unloading port (for free circulation) and with or without pressure relief valve (overload protection).

Technical data (for applications outside these parameters, please consult us!)

General

Size		NG10	NG16
Weight	kg	3.3	7.0
Installation position		Optional	
Ambient temperature range	°C	-30 to +80 (NBR seals) -20 to +80 (FKM seals)	

Hydraulic

Maximum operating pressure	bar	315						
Minimum pressure differential range	bar	3 to 7				5 to 12		
Maximum flow	l/min	10	16	25	50	60	100	160
Flow control	- Temperature-stable (-20 to +80°C)	±2 % ($q_{V \max}$)				±2 % ($q_{V \max}$)		
	- Pressure-stable (to $\Delta p = 315$ bar)	±2 % ($q_{V \max}$)				< ±2 % ($q_{V \max}$)		
Hydraulic fluid		Mineral oil (HL, HLP) to DIN 51524 ¹⁾ ; fast bio-degradable hydraulic fluids to VDMA 24568 (see also RE 90221); HETG (rape seed oil) ¹⁾ ; HEPG (polyglycols) ²⁾ ; HEES (synthetic esters) ²⁾ ; other hydraulic fluids on request						
Hydraulic fluid temperature range	°C	-30 to +80 (NBR seals) -20 to +80 (FKM seals)						
Viscosity range	mm ² /s	2.8 to 380 (recommended: 30 to 46)						
Permissible max. degree of contamination of the hydraulic fluid - cleanliness class to ISO 4406 (c)		Class 20/18/15 ³⁾						

¹⁾ Suitable for NBR and FKM seals

²⁾ Suitable only for FKM seals

³⁾ The cleanliness classes specified for components must be adhered to in hydraulic systems. Effective filtration prevents malfunction and, at the same time, prolongs the service life of components.

For the selection of filters, see data sheets RE 50070, RE 50076, RE 50081, RE 50086, RE 50087 and RE 50088.

Characteristic curves (measured with HLP46, $\vartheta_{oil} = 40 \text{ }^\circ\text{C} \pm 5 \text{ }^\circ\text{C}$)

Flow control (A → B)

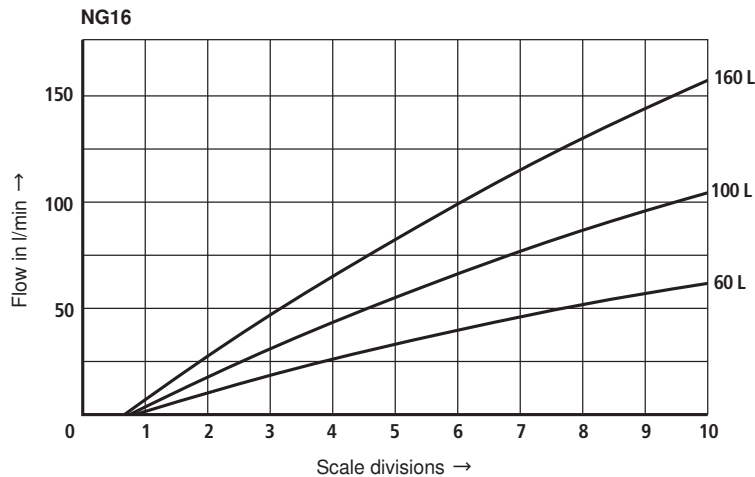
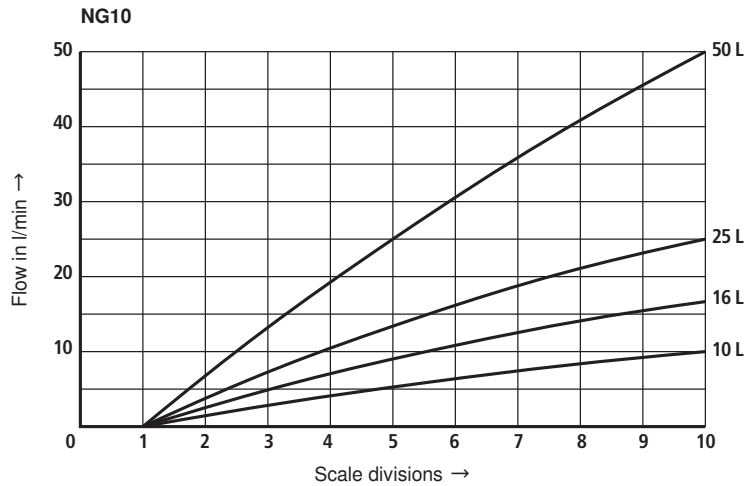

Unit dimensions (dimensions in mm)

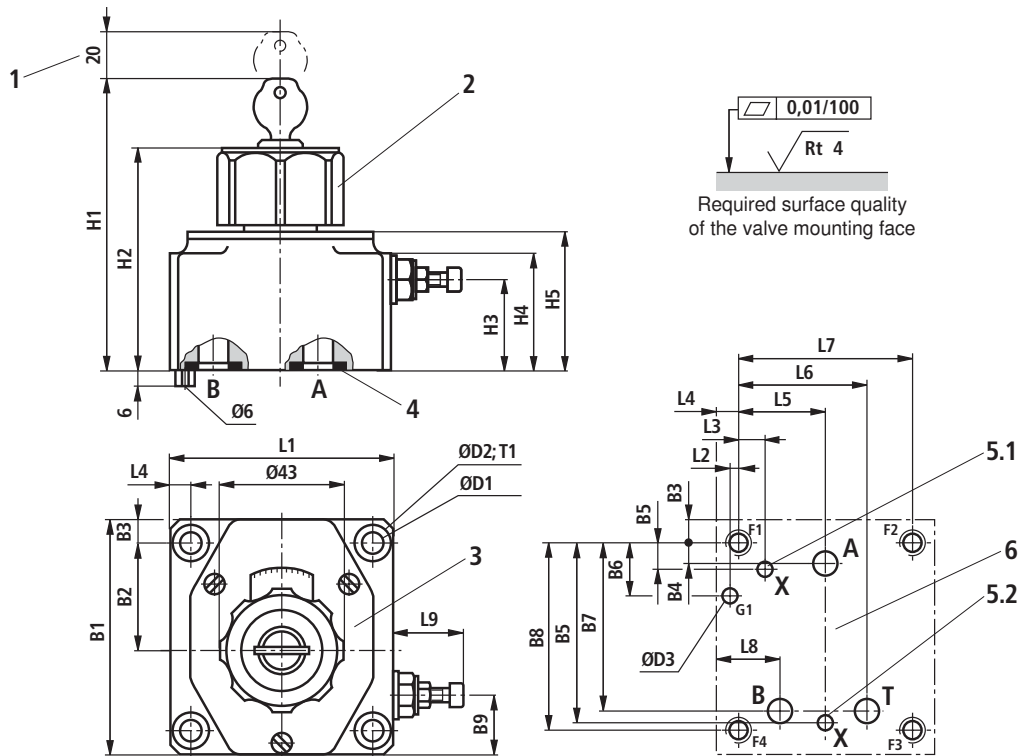

- 1 Space required to remove key
- 2 Adjustment element, rotary knob lock (each position can be locked)
Turning range $300^\circ = 10$ scale divisions; $M_d \approx 0.7$ Nm
- 3 Nameplate
- 4 Identical seal rings for ports A and B
- 5.1 Unloading port X on NG10
- 5.2 Unloading port X on NG16
- 6 Position of ports (similar to ISO 6263)

Valve mounting screws (separate order)

- Size 10
4 pcs ISO 4762 - M8 x 50 - 10.9-fIZn-240h-L
with friction coefficient $\mu_{total} = 0.09$ to 0.14 ,
tightening torque $M_T = 30$ Nm $\pm 10\%$,
Material no. **R913000543**
- Size 16
4 pcs ISO 4762 - M10 x 80 - 10.9-fIZn-240h-L
with friction coefficient $\mu_{total} = 0.09$ to 0.14 ,
tightening torque $M_T = 60$ Nm $\pm 10\%$,
Material no. **R913000496**

Subplates on request

- Size 10: G 337/01 (G1/2)
G 343/01 (G1/2)
- Size 16: G 340/01 (G1)
G 346/01 (G1)

NG	B1	B2	B3	B4	B5	B6	B7	B8	B9	ØD1	ØD2	ØD3	Port			
													X	A. B. T	T1	
10	101.5	47	9.5	9.5	11.9	23.8	74.6	82.5	27	9	15	6	6.3 ¹⁾	14.7 ¹⁾		
16	123.5	60	11	12.5	95.1	28.6	88.8	101.5	76	11	18	6	7.9 ¹⁾	17.5 ¹⁾		
NG	H1	H2	H3	H4	H5	L1	L2	L3	L4	L5	L6	L7	L8	L9 min	L9 max	T1
10	123	93	39.5	51	58	95	3.2	29.5	9.5	11.9	58.2	76	19.1	21.3	29.5	13
16	145	115	58	72	80	123.5	0.8	29.5	11	50.8	77.8	101.5	23.8			12

¹⁾ Maximum dimension

Notes

© This document, as well as the data, specifications and other information set forth in it, are the exclusive property of Bosch Rexroth AG. It may not be reproduced or given to third parties without its consent. The data specified above only serve to describe the product. No statements concerning a certain condition or suitability for a certain application can be derived from our information. The information given does not release the user from the obligation of own judgment and verification. It must be remembered that our products are subject to a natural process of wear and aging.