



ROEMHELD
HILMA ■ STARK

Issue 6-06 E

B 1.7301

Clamping and Supporting Element cartridge-type version, self-locking, double acting, max. operating pressure 300 bar

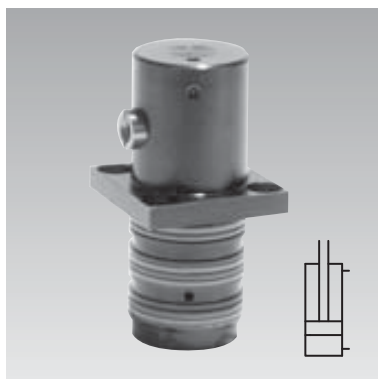

Advantages

- Clamping and support function in one element
- Self-locking wedge clamping
- Re-clamping with hydraulic pressure
- High clamping safety also in case of sudden pressure drop
- Cushioning of vibration
- Space-saving cartridge-type version
- Mounting position: any
- Interchangeable contact bolts
- Oil supply optionally by fittings or through drilled channels
- Standard FKM seals
- Maintenance free

Function

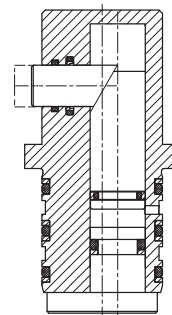

Application

Clamping and supporting elements are used for the following applications:

- Workpieces must be firmly clamped even in case of a pressure drop in the hydraulic system
- Ribbings or webs of workpieces must be clamped by opposite clamping elements in a neutral position and then immovably locked.
- The machining forces are relatively high and directed against the clamping force
- Vibrations in the workpiece have to be cushioned

The round body design of the cartridge-type version allows direct and space-saving installation in the fixture body. Particularly suitable for clamping and supporting in bore holes or recesses of the workpiece.

Description

The clamping and supporting element is a double-acting hydraulic cylinder with a mechanical locking according to the wedge principle. Due to the self-locking design of the wedge principle the element has besides the clamping function also a supporting function. If the workpiece yields or the contact bolt digs deeper into the material due to machining forces or vibrations, the clamping and supporting element re-clamps provided that sufficient clamping pressure is available.

The clamping bolt is protected against torsion and provided with interior thread to allow screwing in of individual contact bolts or shaped parts.

Hydraulic oil is supplied through drilled channels in the fixture body, either horizontally directly in the cartridge-type hole or vertically in the built-in housing, available as accessory, that offers alternatively also the possibility of tube connections.

The version with extended piston rod is provided for mounting of inductive or pneumatic position monitorings.

Installation and connecting possibilities

Cartridge-type version
for horizontally-drilled channels

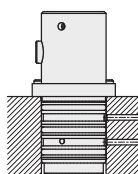

Option

Extended piston rod
for position monitoring

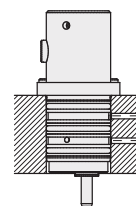

Accessories

Built-in housing
Pipe thread

for vertically-drilled channels

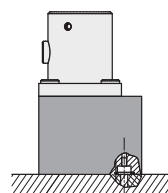
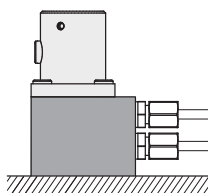

Accessories

Pneumatic or inductive position monitoring

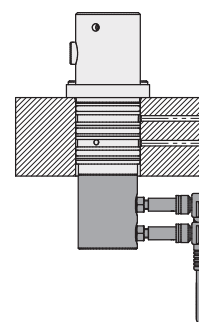

Important notes

- The clamping bolt is protected against torsion, but cannot compensate a permanent torque during operation.
- The clamping and supporting element is not suitable for the use as pull-type cylinder.
- If the clamping and supporting element is uncoupled from oil supply after clamping, e.g. on pallets, we recommend to install an accumulator in order to guarantee a re-clamping effect.
- Further operating conditions, tolerances and other data see data sheet A 0.100.

Application example

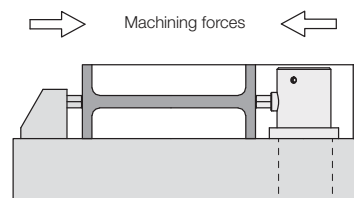

Dimensions Accessories

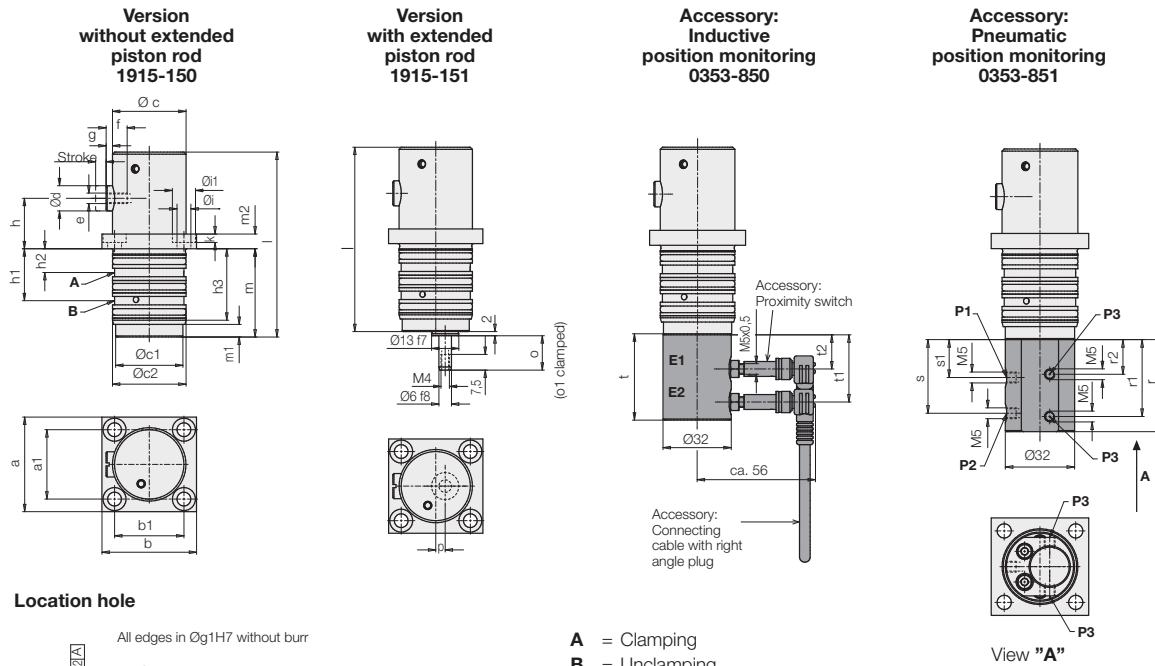

Location hole

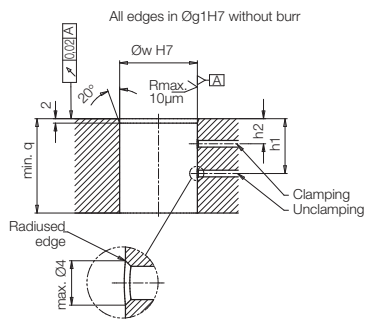

Accessories:

Built-in housing

for tube connection G1/8 or
for manifold mounting with O-ring sealing

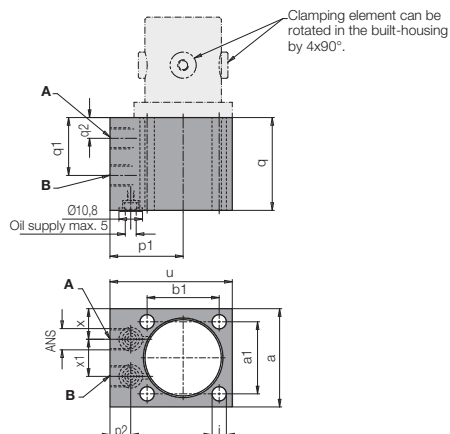

Part no. 0191-500

Accessories:

Intermediate plate for built-in housing

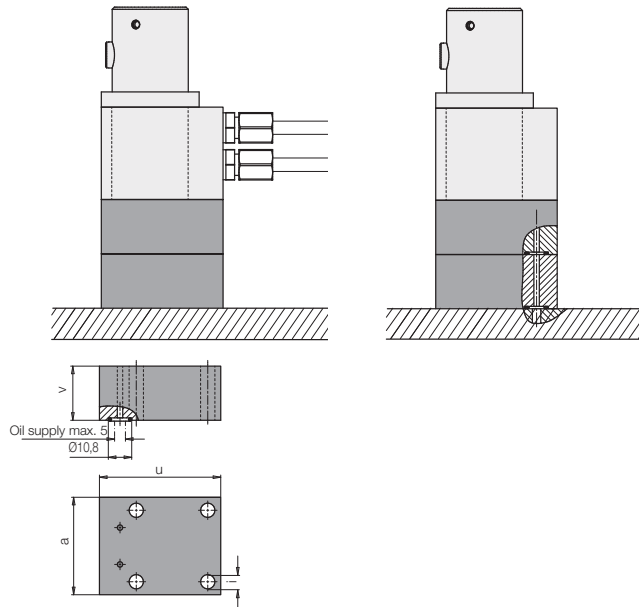

Part no. 0191-501

Dimensions Technical data

Size

Clamping force at 300 bar*	without extended piston rod	[kN]	5.0
Clamping force at 300 bar*	with extended piston rod	[kN]	4.2
Oil volume clamping	without extended piston rod	[cm ³]	2.8
Oil volume clamping	with extended piston rod	[cm ³]	2.4
Oil volume unclamping		[cm ³]	2.2
Stroke		[mm]	5
a		[mm]	45
a1		[mm]	33
b		[mm]	45
b1		[mm]	33
c		[mm]	Ø35
c1		[mm]	Ø32
c2		[mm]	Ø35f7
d		[mm]	Ø12
e			M5
f		[mm]	10
g		[mm]	3
h		[mm]	24
h1		[mm]	24.7
h2		[mm]	11.3
h3		[mm]	34
i		[mm]	Ø6.6
i1		[mm]	Ø11
k		[mm]	4
l		[mm]	88
m		[mm]	42
m1		[mm]	6
m2		[mm]	7
o		[mm]	16.4
o1		[mm]	2.4
p		[mm]	4.5
p1		[mm]	33.5
p2		[mm]	9.5
q		[mm]	42.5
q1		[mm]	26.5
q2		[mm]	9.5
r		[mm]	42.5
r1		[mm]	35.5
r2		[mm]	16
s		[mm]	34
s1		[mm]	17.5
t		[mm]	40
t1		[mm]	31.5
t2		[mm]	16
u		[mm]	56
v		[mm]	25
w		[mm]	Ø35H7
x		[mm]	14
x1		[mm]	17
ANS			G 1/8
Part no.	without extended piston rod		1915-150
Part no.	with extended piston rod		1915-151

clamping force and unclamping pressure

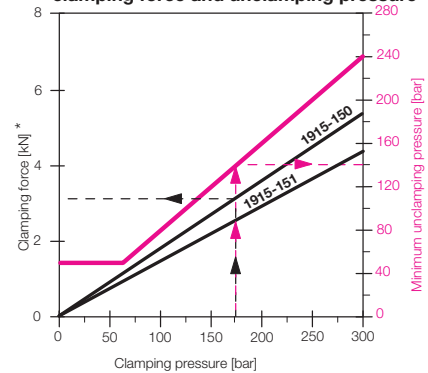

Example:

Clamping and supporting element	1915-150
Clamping pressure	175 bar
Clamping force	3 kN
Min. unclamping pressure	140 bar

* Important note

With the wedge principle the effective clamping force depends on the friction of the sliding surfaces. After several thousand operations with load a smoothing of these sliding surfaces can be noticed, that reduces considerably the adhesion factor and can increase the clamping force up to 75%.

Therefore the indicated clamping forces are minimum values. For unclamping the self-locking of the wedge clamping must be overcome.

That is the reason why the minimum unclamping pressure must be at least 80% of the applied clamping pressure.

Material

Cylinder body:	high alloy steel, black oxide
Piston:	case-hardening steel, hardened
Sealings:	FKM
Wiper:	FKM

Maximum operating temperature

The maximum admissible operating and environmental temperature (without position monitoring) is 150°C.

Accessories

Position monitoring

Since the clamping elements have a clamping range, that can theoretically be used over the complete clamping stroke, the position monitoring is designed so that a signal can be scanned in retracted mode (element in rear stroke position unclamped).

After a clamping stroke of 0.5 mm the „Signal stroke end“ switches off and a „Clamping signal“ will be sent. This signal will be maintained for the complete clamping range (clamping position).

Also in case of pneumatic position monitoring.

Proximity switches are not included in the delivery of inductive position monitorings. These can be ordered separately as accessory.

Inductive proximity switch

for inductive position monitoring 0353-850

Technical data:

Operating voltage UB	10 ... 30 V DC	10 ... 30 V DC
Switching function	Interlock	
Output	PNP	
Filter body material	Stainless steel	
Code class		
as per DIN 40050	IP 67	IP 67
Environmental temperature	-25 ... +70 °C	-25 ... +90 °C
Connection	for plug M8x1	Plug M8x1
LED Function display	yes	Voltage (green) Function display (yellow)
Constant current max.	150 mA	
Rated operating distance	0.8 mm	
Protected against short circuits	yes	
Cable, length of cable		PUR, 5m
Part no.		3829-198 3829-099

Connecting cable with right angle plug for inductive proximity switch

Accessories

	Part no.
Inductive position monitoring (without inductive proximity switch)	0353-850
Inductive proximity switch	3829-198
Connecting cable with right angle plug	3829-099
Pneumatic position monitoring	0353-851
Built-in housing, complete (all required O-rings and plugs are included in our delivery)	0191-500
Intermediate plate (all required O-rings are included in our delivery)	0191-501
Contact bolt M5 (description see data sheet G 3.800)	3614-027
O-Ring for manifold mounting 8x1.5, FKM (spare part)	3000-275
Plug G1/8, flush mounting (spare part)	0361-986
Screw-in plug G 1/8 (alternative)	3610-047

Connecting scheme

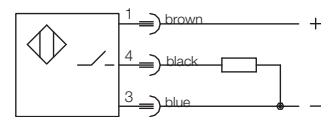

pnp (+) switching