

Industrial
Hydraulics

Electric Drives
and Controls

Linear Motion and
Assembly Technologies

Pneumatics

Service
Automation

Mobile
Hydraulics

Rexroth
Bosch Group

RE 29 070/02.03

Replaces: 12.98

4/3-way fast response valve Type 4WRGE

Nom. size 10 – max. operating pressure 315 bar
Nom. sizes 16, 25 – max. operating pressure 350 bar
Series 1X
Maximum flow 870 L/min

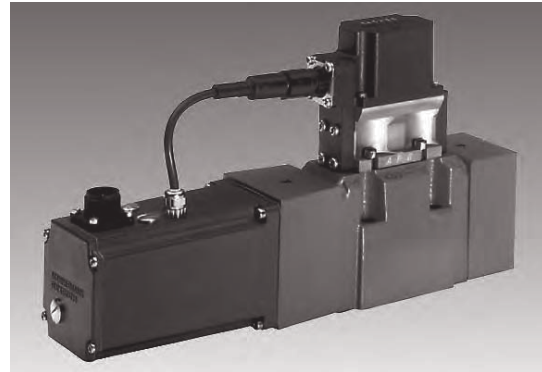

Type 4WRGE 10...L-1X/315G24..K31...

Overview of contents

Contents

Features	Page	1
Ordering details	2	2
Preferred types	3	3
Symbols	3	3
Function, section	4	4
Technical data	5	5
Electrical connections	6	6
Integrated control electronics	7	7
Characteristic curves	8 to 12	8 to 12
Unit dimensions	13 to 15	13 to 15
Pilot oil supply	16	16

Features

- Pilot operated 2-stage fast response valve with electrical closed loop position control of main spool and integrated open and closed loop control electronics
- Suitable for closed loop position, speed, pressure and force closed loop control, with simultaneous high demands on the dynamics in the small signal range and on the response sensitivity
- Pilot control valve:
Single-stage servo valve to the orifice/flapper principle
- Position acquisition of main spool via an inductive position transducer
- High response sensitivity and low hysteresis
- Easily exchangeable filter element
- Integrated control electronics using SMD technology, output stage in thick layer hybrid technology, external zero point correction possible
- For subplate mounting:
Porting pattern to DIN 24 340 form A
Subplates to catalogue sheets RE 45 054 to 45 058 (separate order), see pages 13 to 15



© 2003
by Bosch Rexroth AG, Industrial Hydraulics, D-97813 Lohr am Main

All rights reserved. No part of this document may be reproduced or stored, processed, duplicated or circulated using electronic systems, in any form or by means, without the prior written authorisation of Bosch Rexroth AG. In the event of contravention of the above provisions, the contravening party is obliged to pay compensation.

Ordering details

4WRGE L - 1X / 315 G24 K31/ *

Electrically operated 2-stage fast response directional control valve of 4-way design with servo valve pilot control and integrated control electronics

Nominal size 10 = 10
Nominal size 16 = 16
Nominal size 25 = 25

Symbols

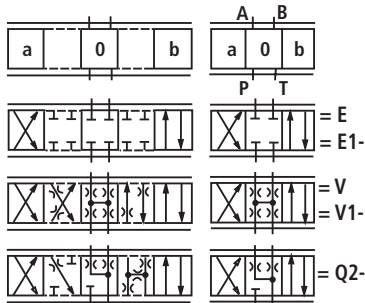

With symbol E1-, V1-:

P → A: q_v B → T: $q_v/2$

P → B: $q_v/2$ A → T: q_v

Note:

With the spools E and E1 there is an overlap of 15 % in the zero position, with the spools V and V1 an overlap from 0 to 0.5 %.

Further details in clear text

M = ¹⁾ NBR seals
V = FKM seals

No code = Without sandwich plate directional valve

WG152 = With sandwich plate directional valve
24 V with component plug
DIN 43 650-AM2,

Without plug-in connector
Plug-in connector – separate order, see page 6

A1 = Command value input ± 10 VDC

C1 = Command value input ± 10 mA

Electrical connections

K31 = With component plug to
E DIN 43 563-AM6-3,

Without plug-in connector,
Plug-in connector – separate order, see page 6

No code =

E =

ET =

T =

Pilot oil supply and drain

Pilot oil supply, external,
Pilot oil drain, external
Pilot oil supply, internal,
Pilot oil drain, external
Pilot oil supply, internal,
Pilot oil drain, internal
Pilot oil supply, external,
Pilot oil drain, internal

G24 = Supply voltage 24VDC

Pilot pressure

10 to 315 bar

315 =

1X = Series 10 to 19

(10 to 19: unchanged installation and connection dimensions)

Characteristic curve form

Linear

L =

Nominal flow in L/min at 10 bar valve pressure differential

50 = or 100 = with nominal size 10

125 = or 200 = with nominal size 16

250 = or 350 = with nominal size 25

¹⁾ Suitable for mineral oil to DIN 51 524

Preferred types

NS 10

Material no.	Type
00954120	4WRGE 10 V50L-1X/315G24ETK31/A1M
00954151	4WRGE 10 V50L-1X/315G24K31/A1M
00954152	4WRGE 10 V1-50L-1X/315G24K31/A1M
00916455	4WRGE 10 V1-50L-1X/315G24ETK31/A1M
00954153	4WRGE 10 V1-100L-1X/315G24K31/A1M

NS 16

Material no.	Type
00954154	4WRGE 16 V125L-1X/315G24ETK31/A1M
00954155	4WRGE 16 V200L-1X/315G24ETK31/A1M
00954156	4WRGE 16 V200L-1X/315G24K31/A1M
00954157	4WRGE 16 V1-200L-1X/315G24ETK31/A1M
00954158	4WRGE 16 V1-200L-1X/315G24K31/A1M

NS 25

Material no.	Type
00954159	4WRGE 25 V250L-1X/315G24ETK31/A1M
00954160	4WRGE 25 V350L-1X/315G24ETK31/A1M
00954161	4WRGE 25 V350L-1X/315G24K31/A1M
00954162	4WRGE 25 V1-350L-1X/315G24ETK31/A1M
00954163	4WRGE 25 V1-350L-1X/315G24K31/A1M

Symbols

General

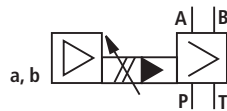

Type 4WRGE...-1X/...

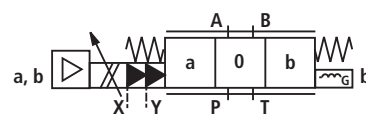

Type 4WRGE...-1X/...E...

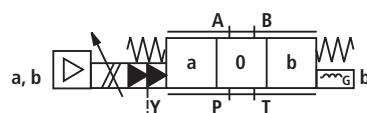

Type 4WRGE...-1X/...ET...

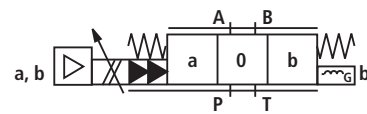

Type 4WRGE...-1X/...T...

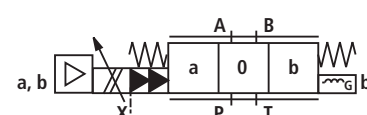

Function, section

The 4/3-way fast response valve is designed for subplate mounting with closed loop position control and integrated control electronics. It infinitely controls the flow proportional to the input signal from P to B and A to T or from P to A and B to T.

Design:

The valve consists of 4 main component groups:

- Low-friction pilot control valve (1) with a 2-gap torque motor; valve housing (2) with orifices (3) and filter (4)
- Housing of main stage (5) with spring centered spool (6)
- Control electronics (7) with amplifier for the control of the pilot control valve (1) and for closed loop position control of the main spool (6)
- Inductive position transducer (8) for position acquisition of the main spool

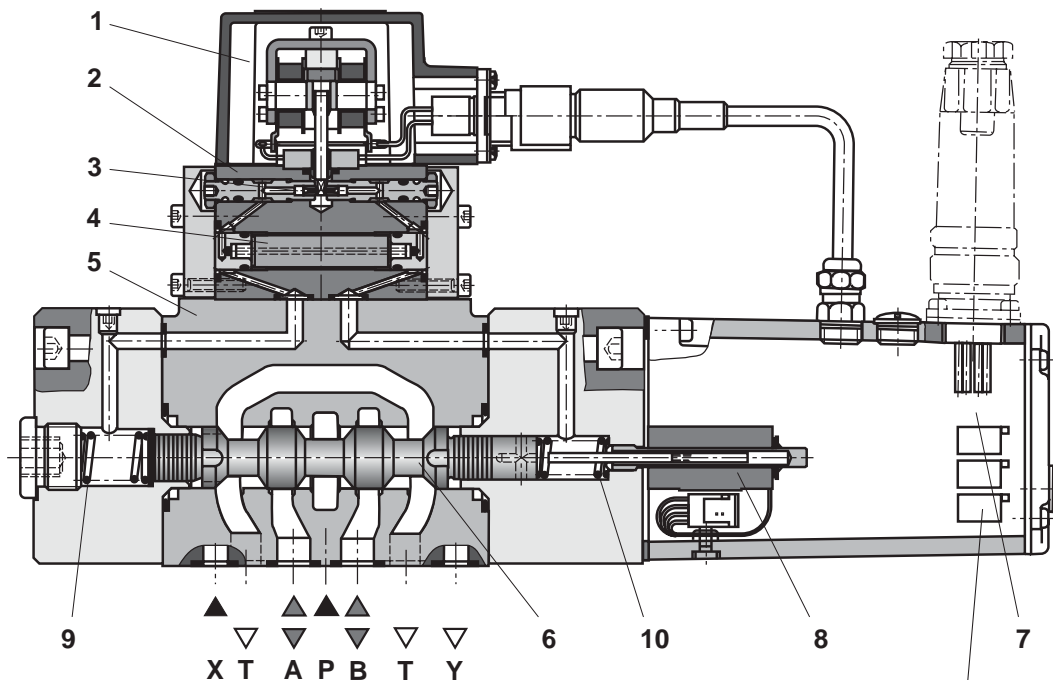

Type 4WRGE 10...-1X/...K31...

R316 Position transducer zero point

Functional description:

- Actuation of pilot control valve via a command value of 0 to ± 10 V or from 0 to ± 10 mA
- Comparison of the command/actual value in the control electronics \rightarrow with control deviation the torque motor is operated and the flapper plate is deflected according to the control amplitude.
- Unbalancing of the pilot pressures via the variable and fixed orifices \rightarrow movement of main spool (6)
- Reaching the position of the main spool according to the command value signal \rightarrow control deviation is reduced to virtually 0 V \rightarrow control process is completed
- Pilot oil supply to pilot control valve internally via port P or externally via port X. Pilot oil drain internally via port T or externally via Y to tank

Attention!

When the supply voltage fails but operating pressure remains available, the main spool (6) moves into an undefined position. The occurring accelerations may cause damage to the machinery.

By using a sandwich plate directional valve (see pages 12 to 14) both pilot lines in the main stage are short circuited when a power failure occurs.

With spool types E, E1 and Q2 the centering springs (9, 10) centre the main spool (6), V and V1 spools are moved into the preferred direction of P to B and A to T within a tolerance range of 1 % to 11 % of the spool stroke. When the operating pressure fails and sandwich plate directional valves are not used the same characteristics apply.

Technical data (for applications outside these parameters, please consult us!)

General		NS 10	NS 16	NS 25	
Installation		optional, preferably horizontal (commissioning guidelines see RE 07 700)			
Ambient temperature range	°C	- 20 to + 50			
Storage temperature range	°C	- 20 to + 80			
Weight	kg	8.0	9.8	18.0	
Hydraulic (measured at $p = 100$ bar, $v = 32$ mm ² /s, $\vartheta = 40$ °C)					
Oper. pressure: Pilot control valve, pilot oil supply	bar	10 to 315			
	Main valve, ports P, A, B	bar	up to 315	up to 350	up to 350
Return pressure: Port T	Pilot oil drain, internal	bar	pressure peaks < 100 permissible		
	Pilot oil drain, external	bar	up to 315	up to 250	up to 250
	Port Y	bar	pressure peaks < 100 permissible		
Nominal flow $q_{V\text{ nom}} \pm 10\%$ at $\Delta p = 10$ bar ¹⁾	L/min	50	125	250	
¹⁾ Δp = valve pressure differential		100	200	350	
Flow of main spool (max. permissible)	L/min	170	460	870	
Stroke of main spool (2-stage)	mm	± 3.5	± 3.5	± 3.5	
Pilot flow at ports X or Y with a jump form of input signal from 0 to 100 %	L/min	2.0	2.0	2.0	
Pressure fluid		mineral oil (HL, HLP) to DIN 51 524 further pressure fluids on request!			
Filter rating of the pilot control valve		100 µm absolute			
Degree of contamination		max. permissible degree of contamination of the pressure fluid is to NAS 1638	A filter with a minimum retention rate of $\beta_x = 75$ is recommended		
	Pilot control valve	class 7	x = 5		
	Main valve	class 9	x = 15		
Pressure fluid temperature range	°C	- 20 to 80; preferably 40 to 50			
Viscosity range	mm ² /s	20 to 380; preferably 30 to 45			
Hysteresis	%	≤ 0.05			
Response sensitivity	%	≤ 0.02			
Reversal span	%	≤ 0.04			
Electrical					
Voltage type		DC			
Signal type		analogue			
Zero balance	%	≤ 2			
Zero deflection with alteration of:					
Pressure fluid temperature	%/10 K	< 0.2	< 0.2	< 0.3	
Operating pressure	%/100 bar	< 0.02	< 0.04	< 0.04	
Return pressure 0 to 10 % from p	%	< 0.01	< 0.02	< 0.02	
Valve protection to DIN 40 050		IP 65			
Control electronics		VT 13037 (integrated in valve, see page 7)			

Note: For details regarding the **environmental simulation test** covering EMC (electro-magnetic compatibility), climate and mechanical loading see RE 29 070-U (declaration regarding environmental compatibility).

Electrical connections

Sandwich plate directional valve WG 152

Plug-in connector to DIN 43 650 -AF2/Pg11

Separate order under material no. **00074684**

(plastic version)

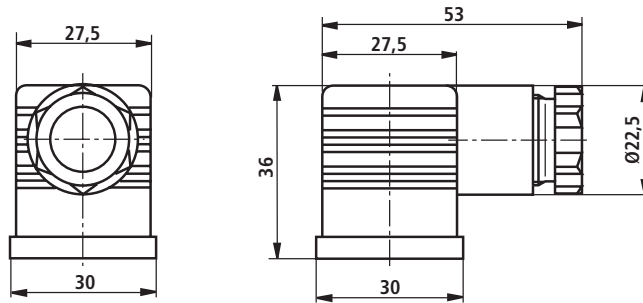

Plug-in connector to E DIN 43 563-BF6-3/Pg11

Separate order under material no. **00021267**

(plastic version)

For pin allocation see block circuit diagram on page 7

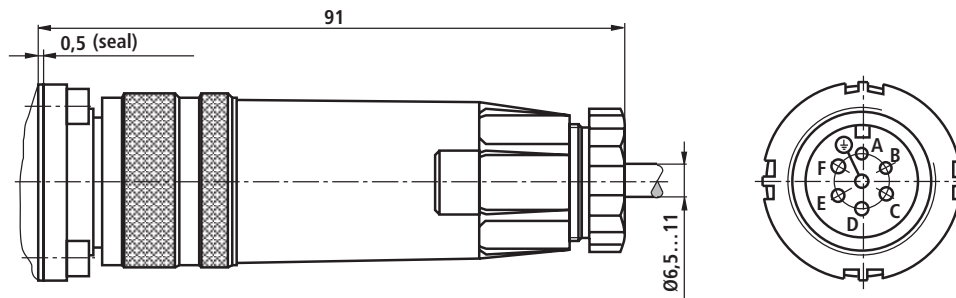

Integrated control electronics

Pin allocation, component plug

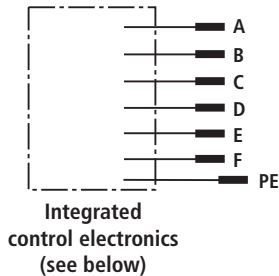

	Pin	Signal ¹⁾
Supply voltage	A	24 VDC (19 to 35 VDC)
	B	GND
	C	n.c.
Differential amplifier input	D	com. value (± 10 V or ± 10 mA)
	E	ref. potential ²⁾
Measurement output	F	act. value (± 10 V or ± 10 mA) against 0 V ³⁾
Earth	PE	connected to valve housing

¹⁾ Supply voltage + 24 VDC ± 25 %; full bridge rectification with smoothing capacitor 2200 μ F; $I_{max} = 230$ mA

²⁾ Current input ± 10 mA \rightarrow input resistance 100 Ω

³⁾ ± 10 mA \rightarrow max. load resistance 1 k Ω

Command value: Reference potential at E and positive command value at D causes flow from P to A and B to T.
Reference potential at E and negative command value at D causes flow from P to B and A to T.

Connection cable: Recommended: – up to 25 m cable length type LiYCY 5 x 0.75 mm²
– up to 50 m cable length type LiYCY 5 x 1.0 mm²
External diameter 6.5 to 11 mm
Connect screen to PE on supply side only.

Note: Electrical signals (e.g. actual value) which are transmitted by the valve electronics must not be used to switch off safety related machinery functions! (Please note the „Safety requirements for fluid power operated machinery and parts – hydraulics“ according to European standard EN 982!)

Block circuit diagram / Terminal allocation of the integrated control electronics type VT13037

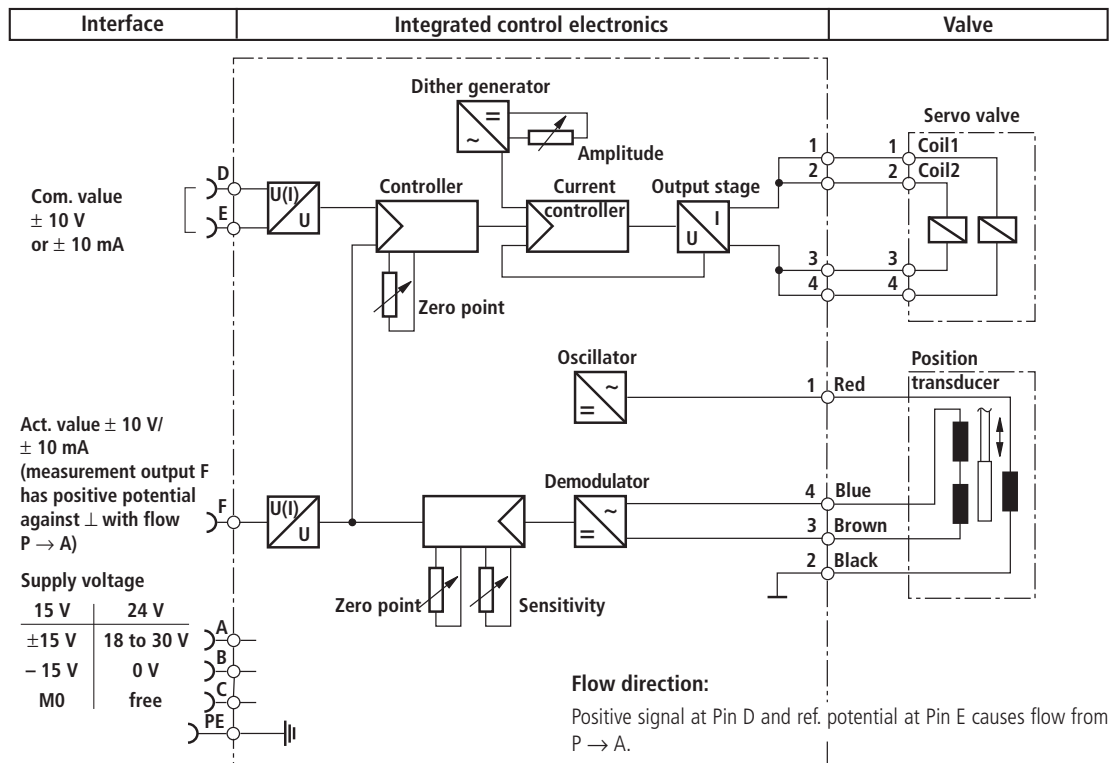

Characteristic curves (measured at $v = 32 \text{ mm}^2/\text{s}$ and $\vartheta = 40 \text{ }^\circ\text{C}$)

All nominal sizes

Pressure-signal-characteristic curve (V spool)

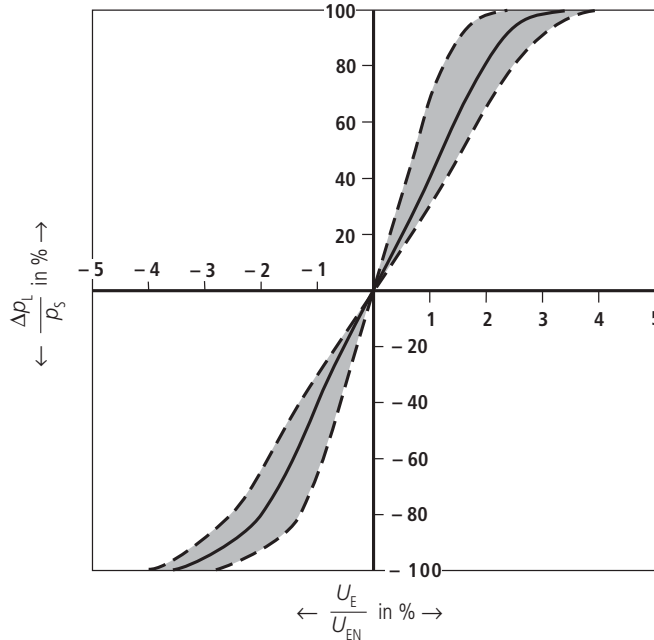

Characteristic curve measured with a pilot control pressure $p_s = 210 \text{ bar}$

Leakage flow 4WRGE...V with pilot control valve in centre position of main spool

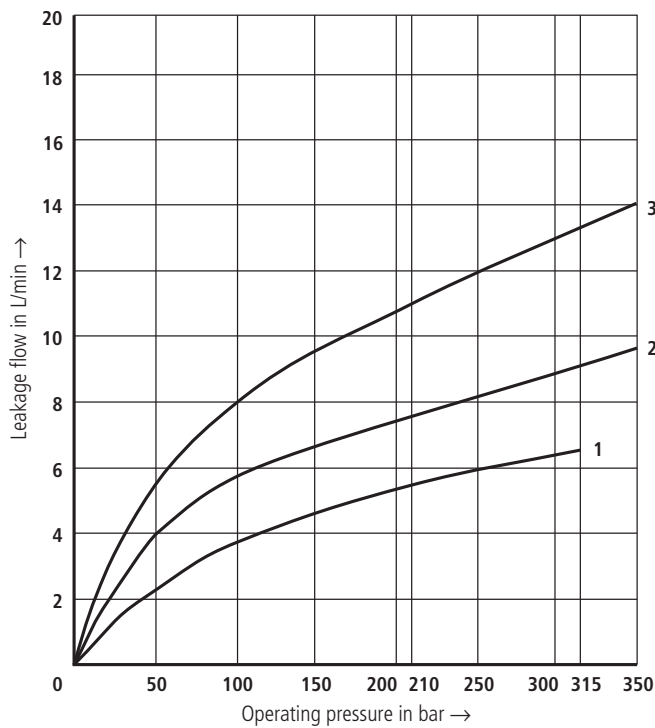

1 = Nominal size 10 (100 L/min)
2 = Nominal size 16 (200 L/min)
3 = Nominal size 25 (350 L/min)

Characteristic curves (measured at $\Delta p = 10$ bar or 5 bar per control land)

Spool symbols E. and V.

Spool with characteristic curve L

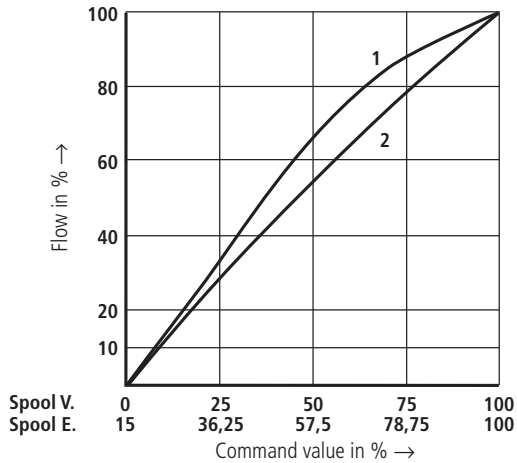

Spool with characteristic curve P

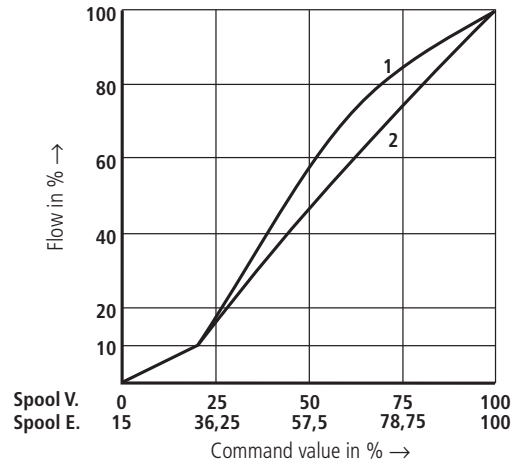

1 = Larger nominal flow
2 = Smaller nominal flow

Spool symbol Q2-

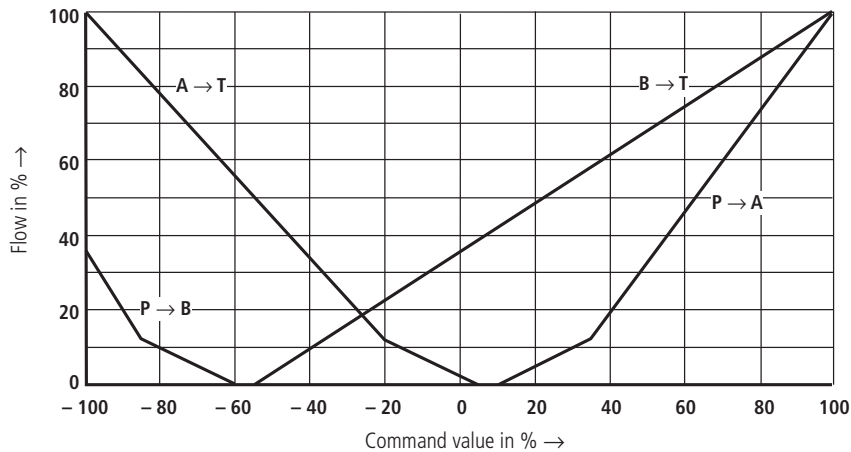

Characteristic curves (measured at $v = 32 \text{ mm}^2/\text{s}$ and $\vartheta = 40 \text{ }^\circ\text{C}$)

NS 10

Transient function with a jump form of electrical input signal

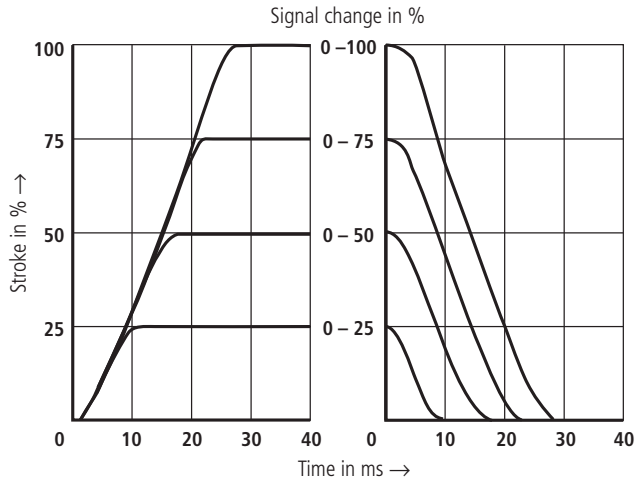

Characteristic curve measured with a pilot control pressure $p_s = 210 \text{ bar}$

Frequency response characteristic curves

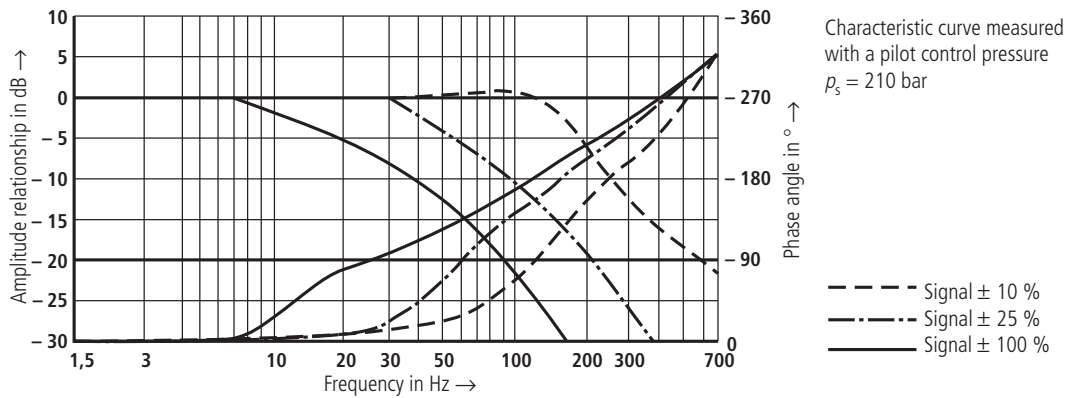

Characteristic curve measured with a pilot control pressure $p_s = 210 \text{ bar}$

Flow/load function at max. valve opening (tolerance $\pm 10 \%$)

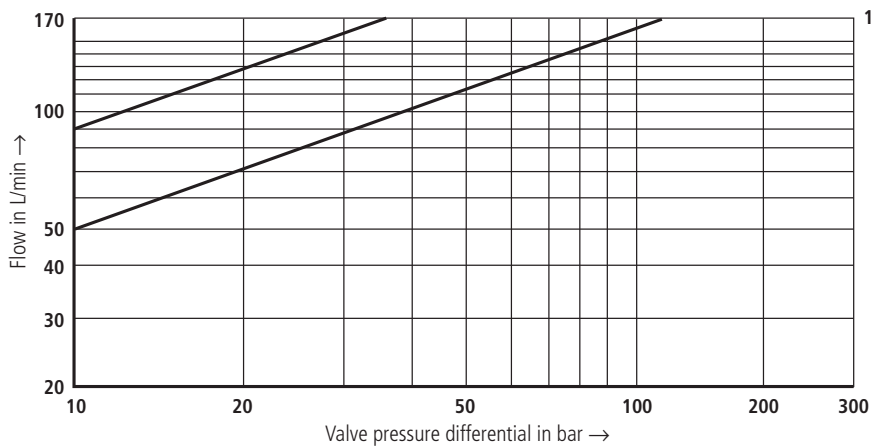

Characteristic curves (measured at $v = 32 \text{ mm}^2/\text{s}$ and $\vartheta = 40 \text{ }^\circ\text{C}$)

NS 16

Transient function with a jump form of input signal

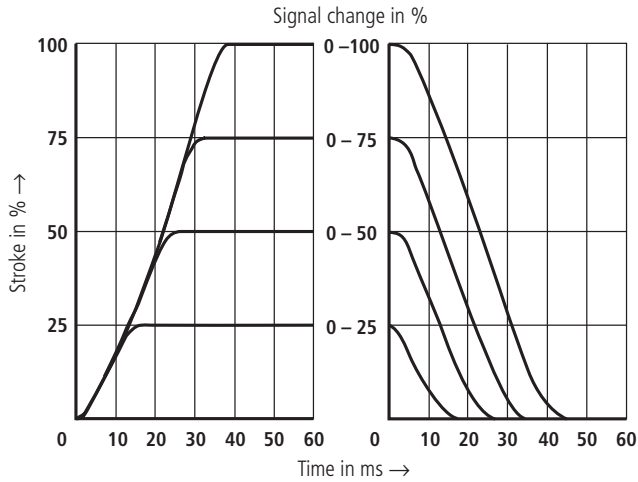

Characteristic curve measured with a pilot control pressure $p_s = 210 \text{ bar}$

Frequency response characteristic curves

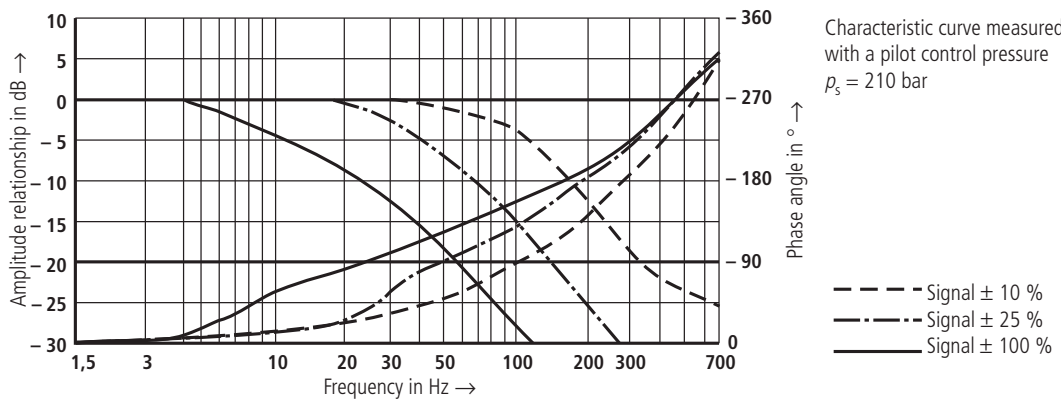

Characteristic curve measured with a pilot control pressure $p_s = 210 \text{ bar}$

Flow/load function at max. valve opening (tolerance $\pm 10 \%$)

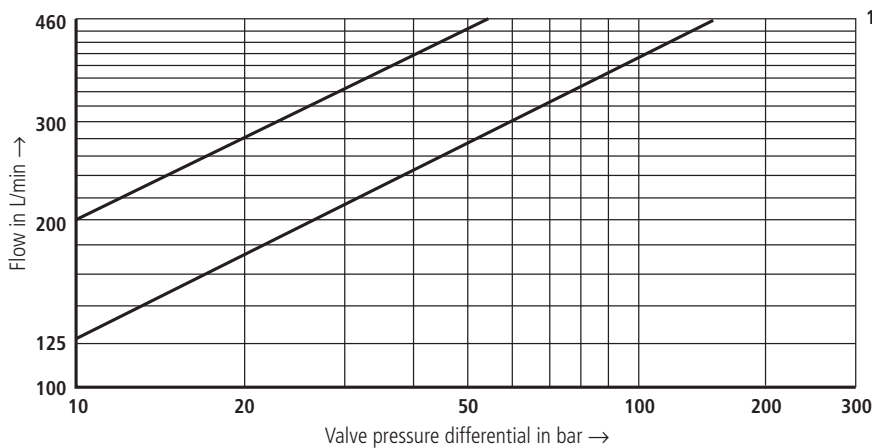

1 = Recommended flow limitation

Characteristic curves (measured at $v = 32 \text{ mm}^2/\text{s}$ and $\vartheta = 40 \text{ }^\circ\text{C}$)

NG 25

Transient function with a jump form of electrical input signal

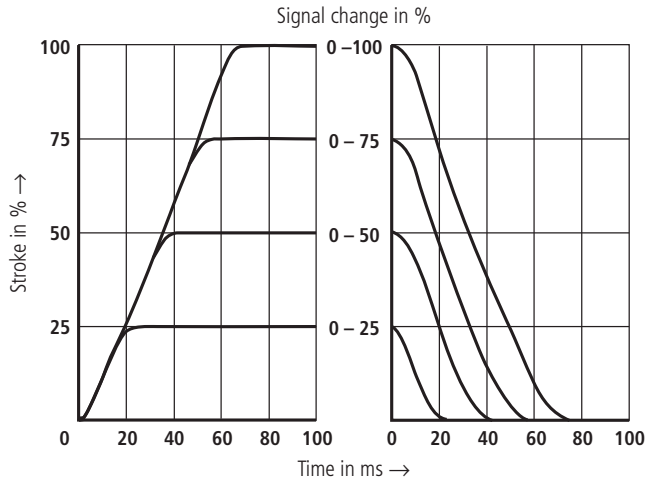

Characteristic curve measured with a pilot control pressure $p_s = 210 \text{ bar}$

Frequency response characteristic curves

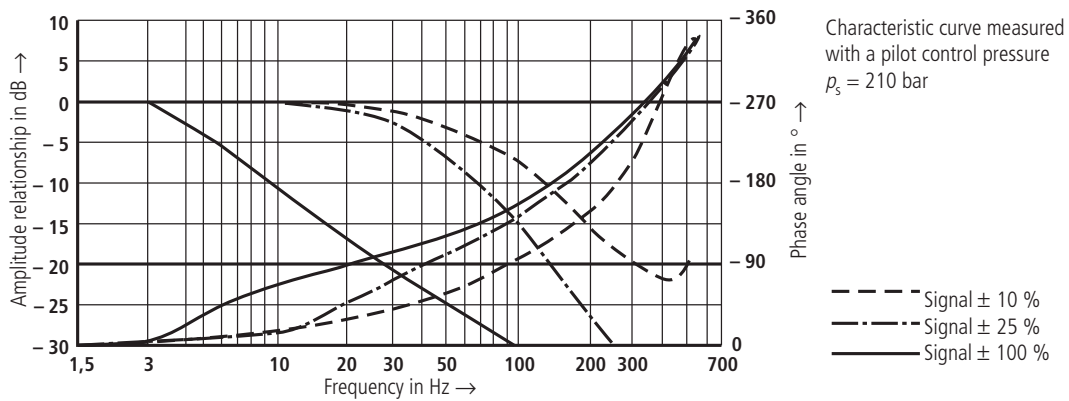

Characteristic curve measured with a pilot control pressure $p_s = 210 \text{ bar}$

Flow/load function at max. valve opening (tolerance $\pm 10 \%$)

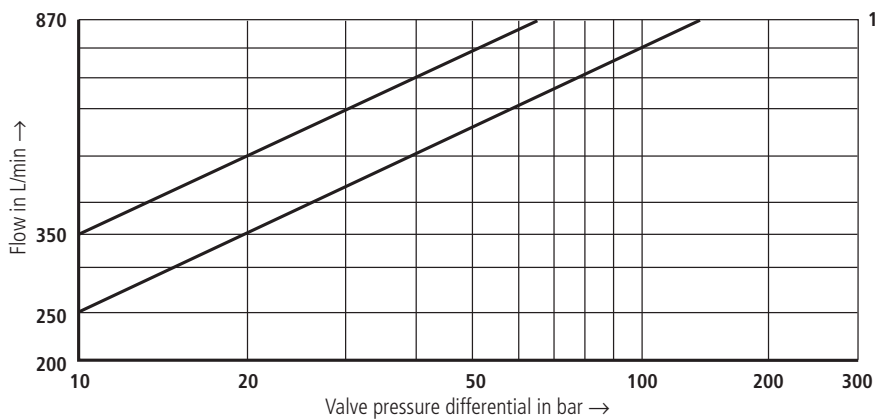

1 = Recommended flow limitation

Unit dimensions: NS 10

(Dimensions in mm)

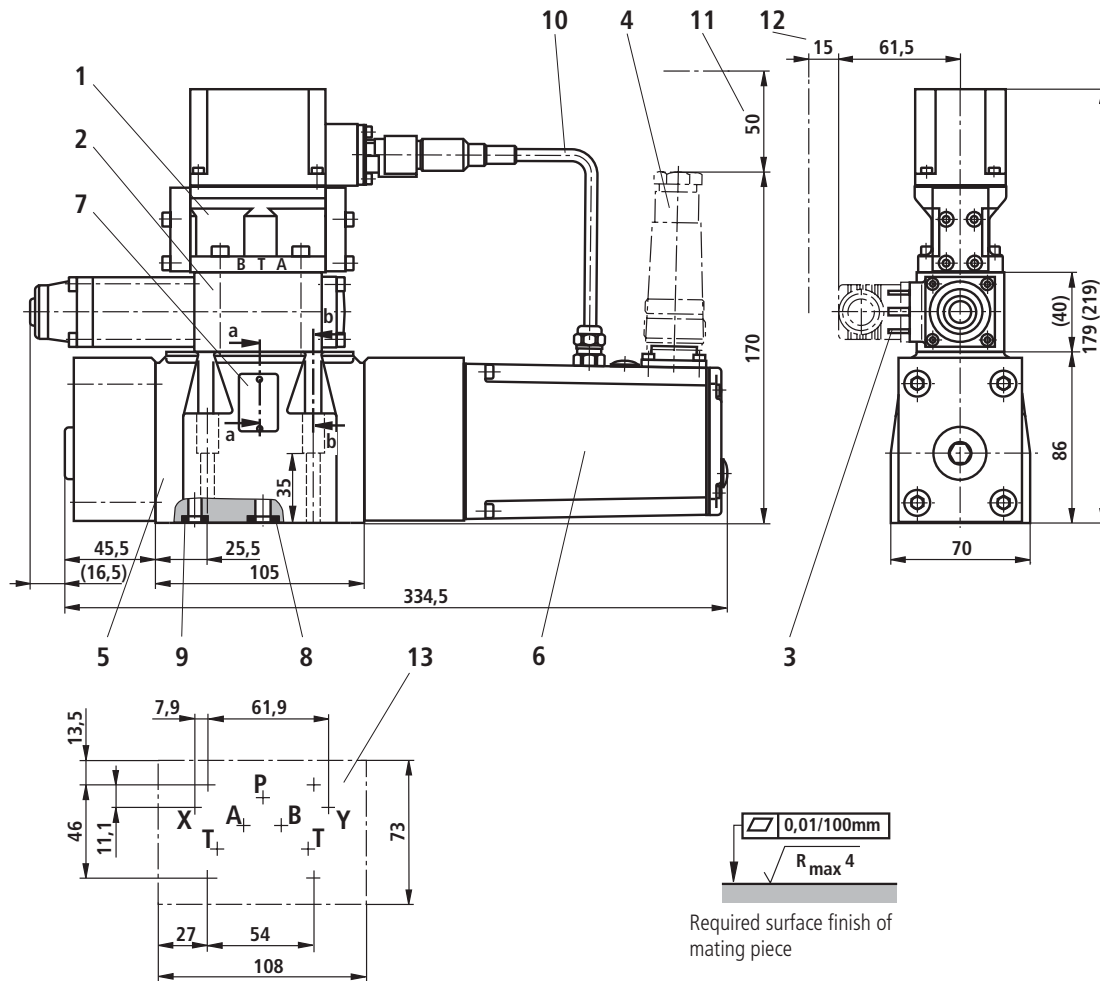

- 1 Pilot control valve
- 2 Sandwich plate directional control valve (only included with ordering detail "...WG152")
- 3 Plug-in connector to DIN 43 650-AF2/Pg11 (separate order, see page 6)
- 4 Plug-in connector to E DIN 43 563-BF6-3/Pg11 (separate order, see page 6)
- 5 Main valve
- 6 Control electronics and inductive position transducer
- 7 Name plate
- 8 R-ring 13 x 1.6 x 2 (ports A, B, P, T)
- 9 R-ring 11.18 x 1.6 x 1.78 (ports X, Y)
- 10 Connection cable
- 11 Space required for connection cable and removal of plug-in connector
- 12 Space required to remove plug-in connector

- 13 Valve mounting surface, porting pattern to DIN 24 340 form A (ports X, Y on request)

Subplates to catalogue sheet RE 45 054 and valve fixing screws must be ordered separately.

Subplates:
G 534/01 (G 3/4)
G 535/01 (G 3/4) with ports X and Y
G 536/01 (G 1) with ports X and Y

Valve fixing screws:
4 off M6 x 45 DIN 912-10.9; $M_A = 15.5 \text{ Nm}$

For section details see page 16.

Unit dimensions: NS 16

(Dimensions in mm)

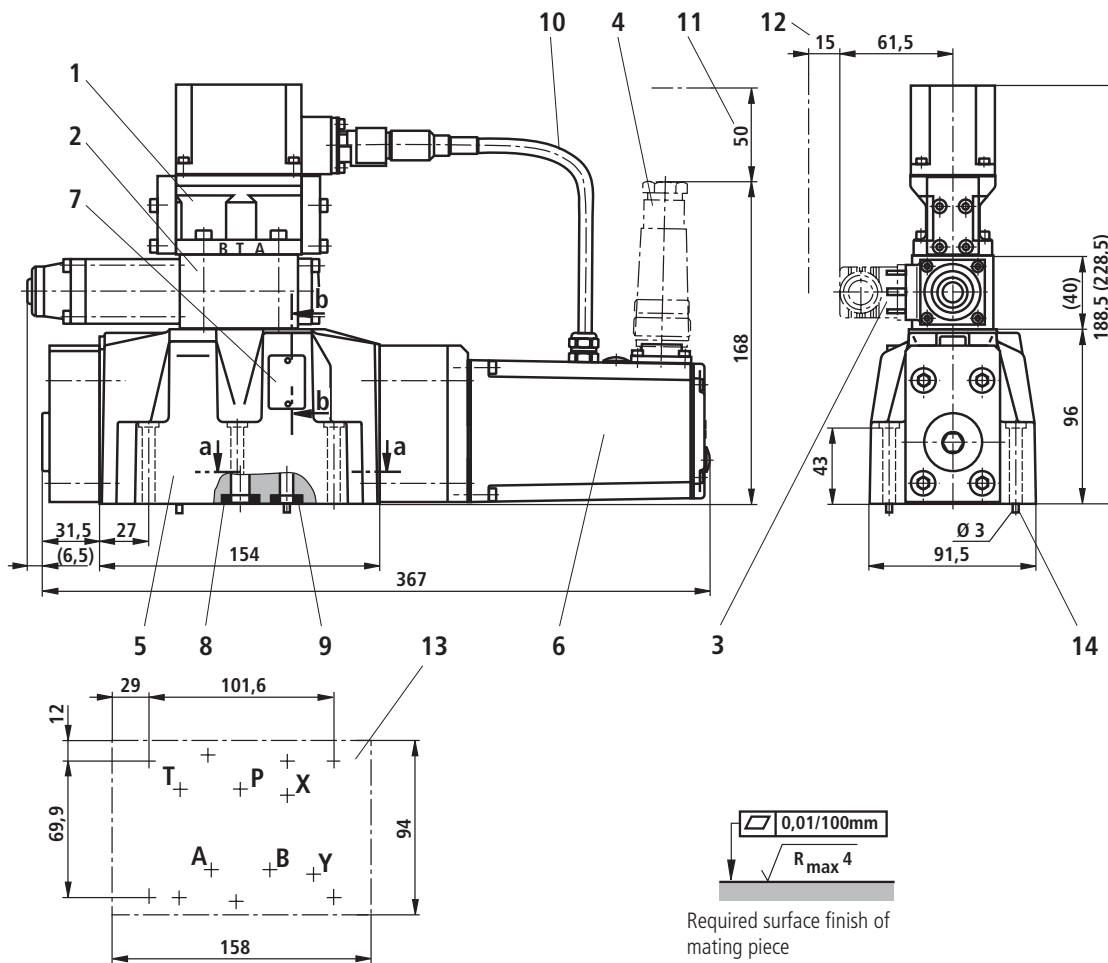

- 1 Pilot control valve
- 2 Sandwich plate directional control valve (only included with ordering detail "...WG152")
- 3 Plug-in connector to DIN 43 650-AF2/Pg11 (separate order, see page 6)
- 4 Plug-in connector to E DIN 43 563-BF6-3/Pg11 (separate order, see page 6)
- 5 Main valve
- 6 Control electronics and inductive position transducer
- 7 Name plate
- 8 R-ring 22.53 x 2.3 x 2.62 (ports A, B, P, T)
- 9 R-ring 10 x 2 x 2 (ports X, Y)
- 10 Connection cable
- 11 Space required for connection cable and removal of plug-in connector
- 12 Space required to remove plug-in connector

- 13 Valve mounting surface, porting pattern to DIN 24 340 form A (ports X, Y on request)
- 14 Locating pin (2 off)

Subplates to catalogue sheet RE 45 054 and valve fixing screws must be ordered separately.

Subplates:

- G 172/01 (G 3/4)
- G 172/02 (M27 x 2)
- G 174/01 (G 1)
- G 174/02 (M33 x 2)

Valve fixing screws:

- 2 off M6 x 60 DIN 912-10.9; $M_A = 15.5 \text{ Nm}$
- 4 off M10 x 60 DIN 912-10.9; $M_A = 75 \text{ Nm}$

For section details see page 16.

Unit dimensions: NS 25

(Dimensions in mm)

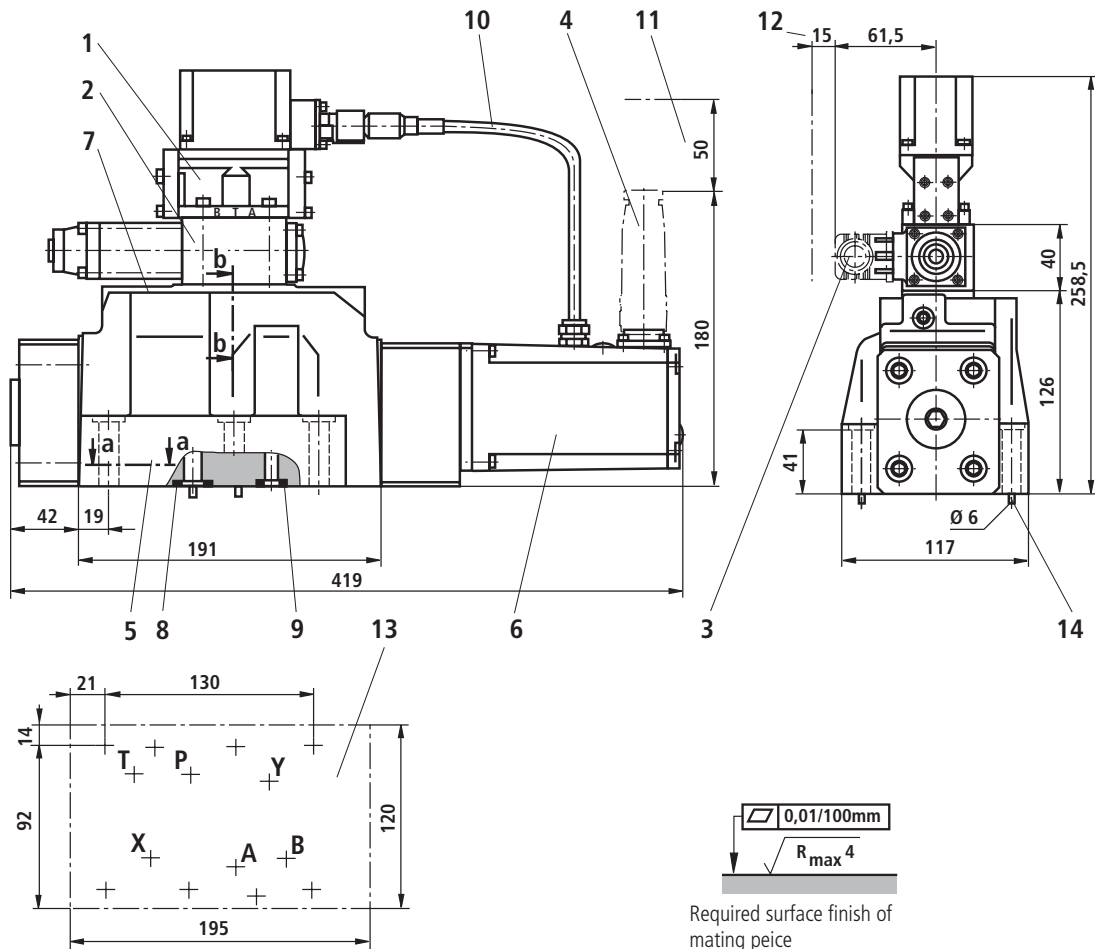

- 1 Pilot control valve
- 2 Sandwich plate directional control valve (only included with ordering detail "...WG152")
- 3 Plug-in connector DIN 43 650-AF2/Pg11 (separate order, see page 6)
- 4 Plug-in connector to E DIN 43 563-BF6-3/Pg11 (separate order, see page 6)
- 5 Main valve
- 6 Control electronics and inductive position transducer
- 7 Name plate
- 8 R-ring 27.8 x 2.6 x 3 (ports A, B, P, T)
- 9 R-ring 19 x 3 x 3 (ports X, Y)
- 10 Connection cable
- 11 Space required for connection cable and removal of plug-in connector
- 12 Space required to remove plug-in connector

- 13 Valve mounting surface, porting pattern to DIN 24 340 form A (ports X, Y on request)
- 14 Locating pin (2 off)

Subplates to catalogue sheet RE 45 054 and valve fixing screws must be ordered separately.

Subplates:
 G 151/01 (G 1)
 G 154/01 (G 1 1/4)
 G 156/01 (G 1 1/2)

Valve fixing screws:
 6 off M12 x 60 DIN 912-10.9; $M_A = 130$ Nm

For section details see page 16.

Pilot oil supply

Type 4WRGE...-1X/...

Pilot oil supply, external Pilot oil drain, external

With this version the pilot oil supply is from a separate pilot pressure circuit (external).
The pilot oil drain is not into the T port of the main valve but separately into the tank via port Y (external).

Type 4WRGE...-1X/...E...

Pilot oil supply, internal Pilot oil drain, external

With this version the pilot oil supply is from the P port of the main valve (internal).
The pilot oil drain is not into the T port of the main valve but separately into the tank via port Y (external).
Port X must be plugged in the subplate.

Type 4WRGE...-1X/...ET...

Pilot oil supply, internal Pilot oil drain, internal

With this version the pilot oil supply is from the P port of the main valve (internal).
The pilot oil drain is directly into the T port of the main valve (internal).
Ports X and Y must be plugged in the subplate.

Type 4WRGE...-1X/...T...

Pilot oil supply, external Pilot oil drain, internal

With this version the pilot oil supply is from a separate pilot pressure circuit (external).
The pilot oil drain is directly into the T port of the main valve (internal).
Port Y must be plugged in the subplate.

Positions **1** and **2**: Plug M6 DIN 906-8.8 A/F 3

NS 10 For section diagram see page 12

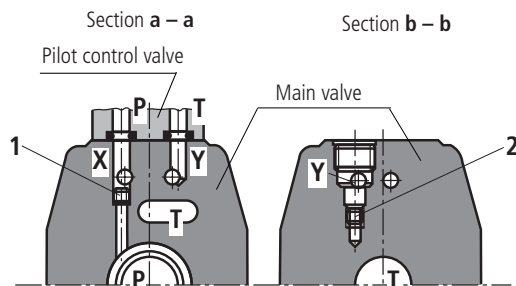

Pilot oil supply (section a – a)	external: 1	closed
	internal: 1	open
Pilot oil drain (section b – b)	external: 2	closed
	internal: 2	open

NS 16 For section diagram see page 13

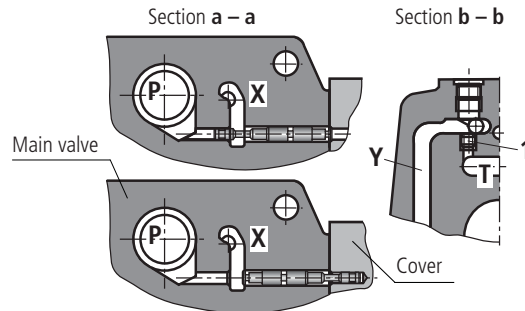

Pilot oil supply (section a – a)	external: P	closed
	internal: P	open
Pilot oil drain (section b – b)	external: 1	closed
	internal: 1	open

NS 25 For section diagram see page 14

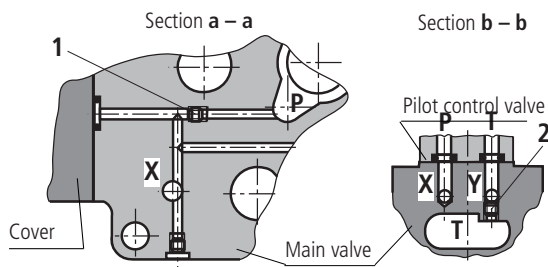

Pilot oil supply (section a – a)	external: 1	closed
	internal: 1	open
pilot oil drain (section b – b)	external: 2	closed
	internal: 2	open

The data specified above only serves to describe the product. No statements concerning a certain condition or suitability for a certain application can be derived from our information. The details stated do not release you from the responsibility for carrying out your own assessment and verification. It must be remembered that our products are subject to a natural process of wear and ageing.