



ROEMHELD
HILMA ■ STARK

Issue 3-16 E

B 1.950

Threaded-Body Work Supports max. operating pressure 500 bar

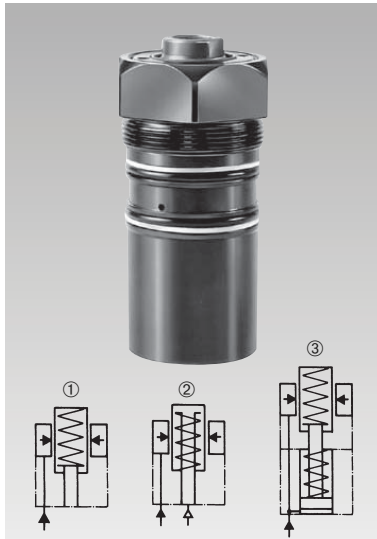

There are three variations of plunger actuation:

- 1. Spring advanced;** plunger extended in off-position (see page 2).
- 2. Air pressure advanced;** plunger retracted in off-position. The pneumatically-actuated plunger allows precise setting of the plunger contact force by means of a pressure reducing valve (see page 3).
- 3. Hydraulic pressure and spring advanced;** plunger retracted in off-position. It moves forward with a light spring force against the workpiece, when hydraulic pressure is applied (see page 4).

Installation example

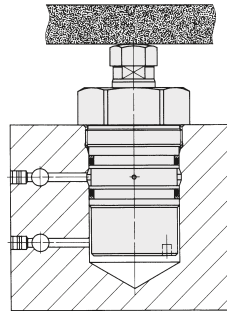

Application

Hydraulic work supports are used to provide a self-adjusting rest for the workpiece during the machining operations. They compensate the workpiece surface irregularities, also deflection and vibration under machining loads.

Function

Hydraulic locking is made together with hydraulic clamping of the workpiece, or independently. Three different sizes are available. Each of these can be combined with swing clamps as per data sheet B 1.881 or B 1.892 (see combination possibilities).

Installation

The threaded-body design of the elements allows direct installation in clamping fixtures, in horizontal or vertical mounting position, and thereby a space-saving arrangement. Hydraulic oil is fed through drilled channels in the fixture body.

Important note!

Work supports are not suitable to compensate side loads.
Operating conditions, tolerances and other data see data sheet A 0.100.
It is absolutely necessary to follow the instructions for venting of the spring area on data sheet A 0.110.

Combination possibilities

Threaded-body work support combined with flange-mounted swing clamps as per data sheet B 1.891

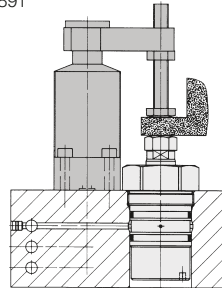

Threaded-body work support combined with threaded-body swing clamps as per data sheet B 1.892

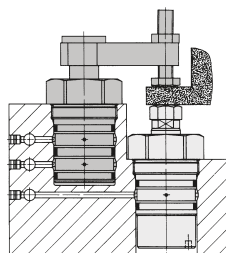

Important note

Support and clamping forces have to be adapted to each other, so that there will be sufficient force reserve available for the threaded-body work support to absorb the machining forces.

Thumb rule: Support force $\geq 2 \times$ opposing force

The diagrams below show the graphs of the clamping and support forces for the 3 possible combinations.

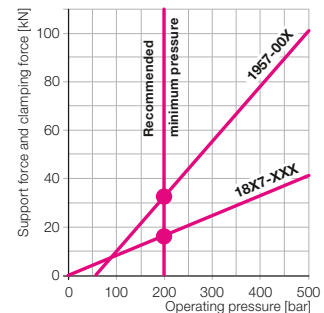
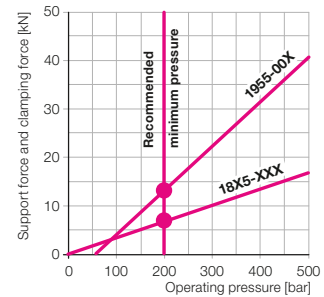
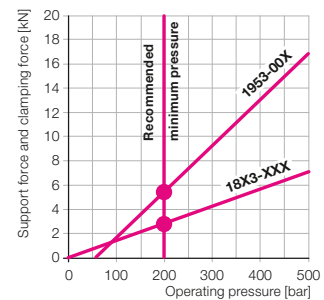

Example

Swing clamps 1895-506 clamps against threaded-body work support 1955-002. Operating pressure 200 bar.

Support force 14 kN
Clamping force 7 kN
7 kN = possible opposing force

**Version: off-position extended, contact by spring force
max. operating pressure 500 bar**

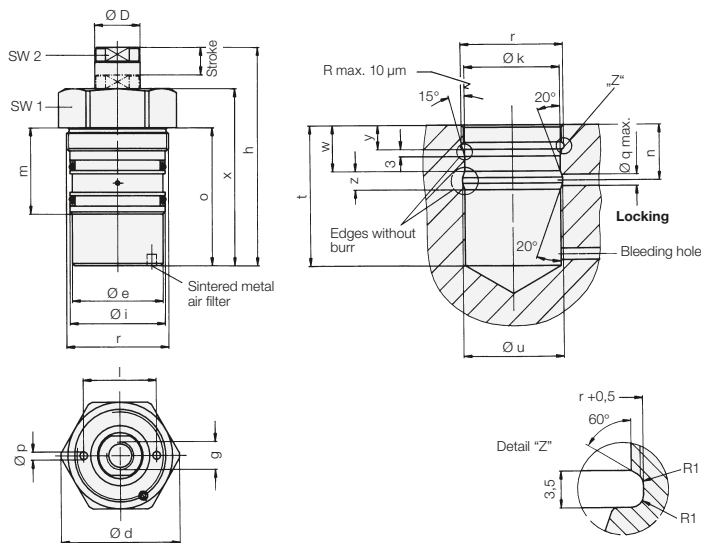
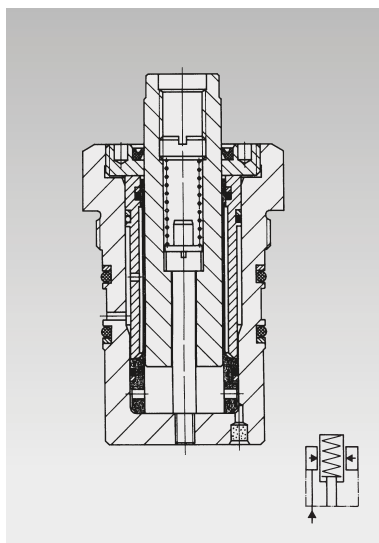

The support plunger is extended in off-position. When the workpiece is inserted the plunger is pushed back. The contact force of the installed pressure spring depends on the stroke of the plunger. Afterwards the plunger is hydraulically locked.

The support plunger is provided with female thread to enable the use of threaded pieces for height adjustment.

The internal part of the work support is protected against dust and swarf by a sintered metal air filter. Liquids must not be sucked in by the filter. A corresponding protection cover has to be provided.

It is absolutely necessary to follow the instructions for venting of the spring area on data sheet A 0.110.

The support plunger must always be protected against penetration of contamination by a contact bolt (see accessory) or a plug.

Accessories

Contact bolts see data sheet G 3.800.

Plunger Ø D	[mm]	20	32	50
Stroke	[mm]	12	16	20
Support force at 200/500 bar	[kN]	5.6/16.8	14/42	34/102
Plunger contact force min./max.	[N]	15/25	30/60	50/100
Ø d	[mm]	52	64	100
Ø e	[mm]	41	53	83
g x depth of thread	[mm]	M 12 x 12	M 12 x 12	M 16 x 20
h	[mm]	95	119	174
Ø i f7	[mm]	42	55	85
Ø k H7	[mm]	42	55	85
l	[mm]	-	-	86
m	[mm]	36	45	60
n	[mm]	24	29	41
o	[mm]	60	66	126
Ø p / deep	[mm]	-	-	8/9
Ø q max.	[mm]	5	5	6
r	[mm]	M 45 x 1.5	M 60 x 1.5	M 90 x 2
t	[mm]	61	67	127
Ø u	[mm]	44	57	87
w	[mm]	20	24	36
x	[mm]	77	99	146
y	[mm]	10.5	12.5	20.5
z	[mm]	8	10	10
SW 1	[mm]	46	55	95
SW 2	[mm]	17	27	41

Part no.

1953-000 1955-000 1957-000*

Spare seals – Seal kit for external seals

0131-525

0131-527

0131-529

* with metallic wiper edge

Adm. support force F as function of the operating pressure p

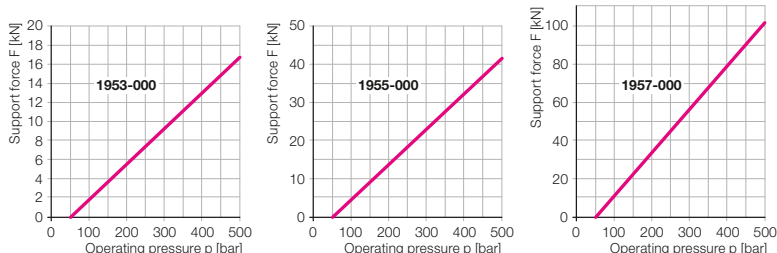

Version: extend and contact by air pressure
max. operating pressure 500 bar

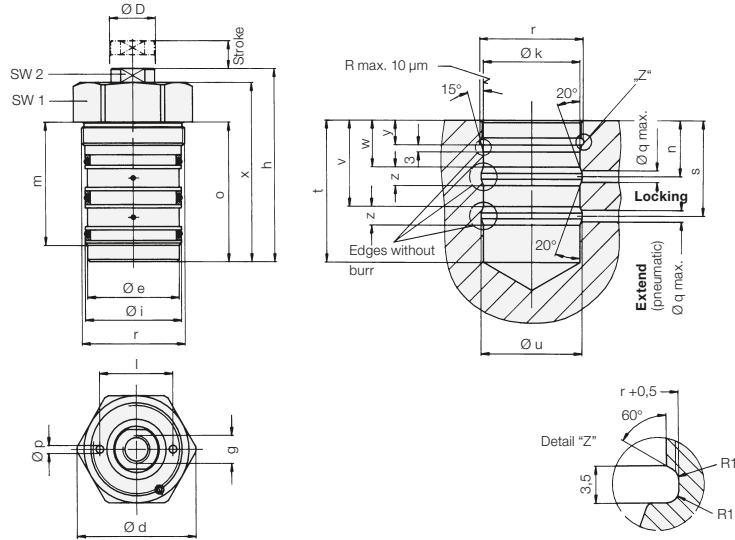
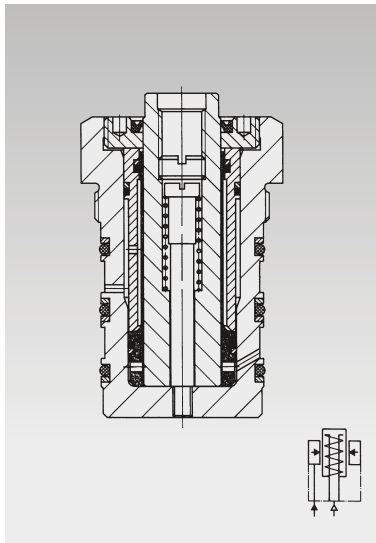

The support plunger is retracted in off-position.
The pneumatically-actuated plunger allows precise setting of the plunger contact force by means of a pressure reducing valve.
The support plunger is provided with female thread to enable the use of threaded pieces for height adjustment.
The support plunger must always be protected against penetration of contamination by a contact bolt (see accessory) or a plug.

Accessories

Contact bolts see data sheet G 3.800.

Plunger $\varnothing D$	[mm]	20	32	50
Stroke	[mm]	12	16	20
Support force at 200/500 bar	[kN]	5.6/16.8	14/42	34/102
Spring force min./max.	[N]	15/25	30/60	50/100
Plunger contact force at 1 bar air pressure (deduct spring force, if necessary)	[N]	31	80	196
$\varnothing d$	[mm]	52	64	100
$\varnothing e$	[mm]	41	53	83
g x depth of thread	[mm]	M 12 x 12	M 12 x 12	M 16 x 20
h	[mm]	83	103	154
$\varnothing i$ f7	[mm]	42	55	85
$\varnothing k$ H7	[mm]	42	55	85
l	[mm]	-	-	86
m	[mm]	53	64	85
n	[mm]	24	29	41
o	[mm]	60	66	126
$\varnothing p$ / deep	[mm]	-	-	8/9
$\varnothing q$ max.	[mm]	5	5	6
r	[mm]	M 45 x 1.5	M 60 x 1.5	M 90 x 2
s	[mm]	41	46.5	64
t	[mm]	61	67	127
$\varnothing u$	[mm]	44	57	87
v	[mm]	37	41.5	59
w	[mm]	20	24	36
x	[mm]	77	99	146
y	[mm]	10.5	12.5	20.5
z	[mm]	8	10	10
SW 1	[mm]	46	55	95
SW 2	[mm]	17	27	41

Part no	1953-001	1955-001	1957-001*
Spare seals – Seal kit for external seals	0131-524	0131-526	0131-528

* with metallic wiper edge

Adm. support force F as function of the operating pressure p

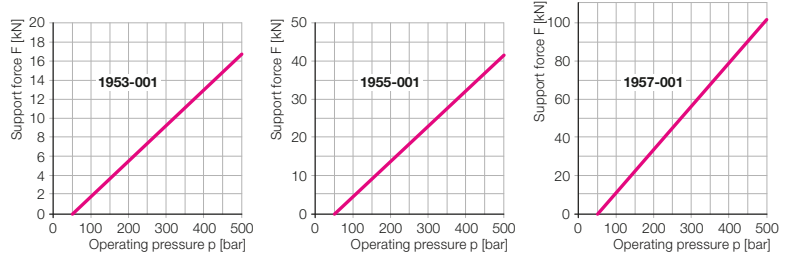

**Version: extending hydraulically, contact by spring force
max. operating pressure 500 bar**

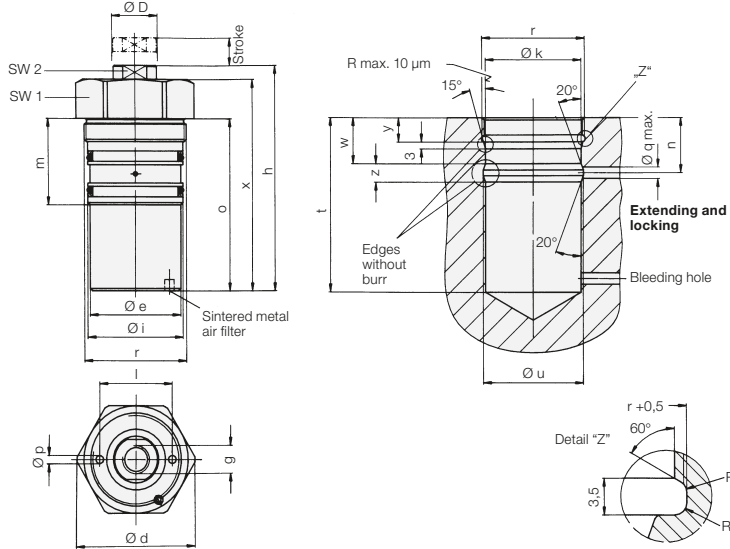
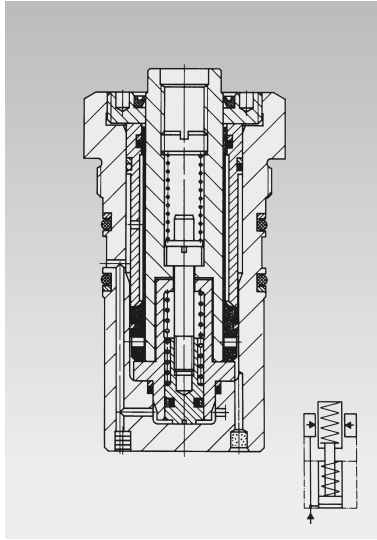

The support plunger is retracted in off-position. When pressurised the support plunger moves against the inserted workpiece by means of light spring force. The contact force of the installed pressure spring depends on the stroke of the plunger. With increasing oil pressure, the plunger locks hydraulically. After the system has been unclamped, the support plunger returns to off-position. The support plunger is provided with female thread to enable the use of threaded pieces for height adjustment. The internal part of the work support is protected against dust and swarf by a sintered metal air filter. Liquids must not be sucked in by the filter. A corresponding protection cover has to be provided. It is absolutely necessary to follow the instructions for venting of the spring area on data sheet A 0.110. The support plunger must always be protected against penetration of contamination by a contact bolt (see accessory) or a plug.

Accessories

Contact bolts see data sheet G 3.800.

Plunger Ø D	[mm]	20	32	50
Stroke	[mm]	12	16	20
Support force at 200/500 bar	[kN]	5.6/16.8	14/42	34/102
Plunger contact force min./max.	[N]	15/25	30/60	50/100
Max. oil flow rate	[cm ³ /sec]	25	35	100
Required oil per stroke	[cm ³]	1.0	3.3	9.8
Ø d	[mm]	52	64	100
Ø e	[mm]	41	53	83
g x depth of thread	[mm]	M 12 x 12	M 12 x 12	M 16 x 20
h	[mm]	98	120	172
Ø i f7	[mm]	42	55	85
Ø k H7	[mm]	42	55	85
l	[mm]	-	-	86
m	[mm]	36	45	60
n	[mm]	24	29	41
o	[mm]	75	83	144
Ø p / deep	[mm]	-	-	8/9
Ø q max.	[mm]	5	5	6
r	[mm]	M 45 x 1.5	M 60 x 1.5	M 90 x 2
t	[mm]	76	84	145
Ø u	[mm]	44	57	87
w	[mm]	20	24	36
x	[mm]	92	116	164
y	[mm]	10.5	12.5	20.5
z	[mm]	8	10	10
SW 1	[mm]	46	55	95
SW 2	[mm]	17	27	41
Part no.		1953-002	1955-012	1957-002*
Spare seals – Seal kit for external seals		0131-525	0131-527	0131-529

* with metallic wiper edge

Adm. support force F as function of the operating pressure p

