



HC2D- D miniBOOSTER



Up to 2.5 times the volume

HC2D- D versions: 13 different intensification factors

P_{IN}: 20 – 207 bar (inlet pressure)

P_{RETURN}: As low as possible (return pressure to tank)

P_H: 800 bar maximum (outlet pressure)

P_{OUTLET}: $P_H = (P_{IN} - P_{RETURN}) \times i$ (intensification)

Mounting: Flange, manifold system miniBOOSTER pattern

Accessories: Pilot- operated dump valve available

A model = no dump valve

B model = with dump valve

G model = direct proportionally controlled

Mat. Certificate 3.1 on request

Description

The HC2D- D is a high- flow dual- acting unit which is capable of delivering up to 11.0 l/ min flow on the high- pressure end. Like other miniBOOSTER models, the HC2D- D raises supplied pressure to a higher outlet pressure and automatically compensates for consumption of oil to maintain the high pressure. Adjustment of the outlet pressure is carried out by varying the supplied pressure. Relative to its flow capability, the HC2D- D is a compact unit weighing 3.5 kg. The entire pattern is a miniBOOSTER design.

Flow rates

Intensification factor i	Max. outlet flow l/ min	Max. inlet flow l/ min
1.2	11.0	15.0
1.4	10.6	15.0
1.6	10.2	15.0
1.9	8.8	15.0
2.2	7.8	15.0
2.6	7.0	15.0
3.2	6.2	15.0
4.0	5.0	14.0
5.0	4.0	14.0
6.6	3.2	13.0
9.0	2.2	13.0
13.0	1.5	12.0
20.0	0.7	12.0



Dimensions

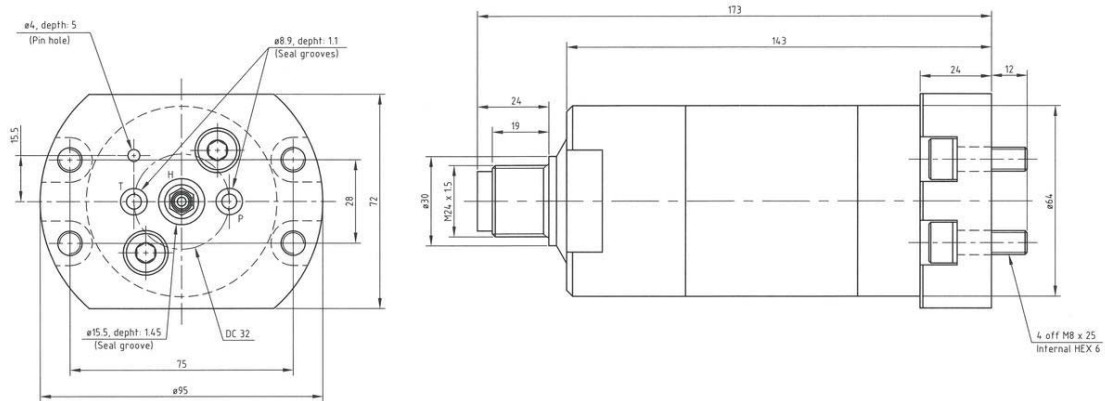

2D-121-03

Functions

The basic operation is illustrated in the function diagram. Oil is fed through the directional valve CV to the IN port, flowing freely through the check valves 2x KV1, 2x KV2 and DV to the high- pressure side H. In this condition maximum flow trough the booster is achieved giving a fast-forward function.

When pump pressure is reached on the high- pressure side H, valves KV1, KV2 and DV will close. The end pressure will be achieved by the oscillating pump units OP1 and OP2 by turns. The unit will automatically stall when end pressure on high- pressure side H is reached. If a pressure drop on the high- pressure side exists due to consumption or leakage, the OP1 and OP2 units will automatically operate to maintain the end pressure. It is possible to change the high- pressure connection H to the opposite end of the booster.

Function diagram

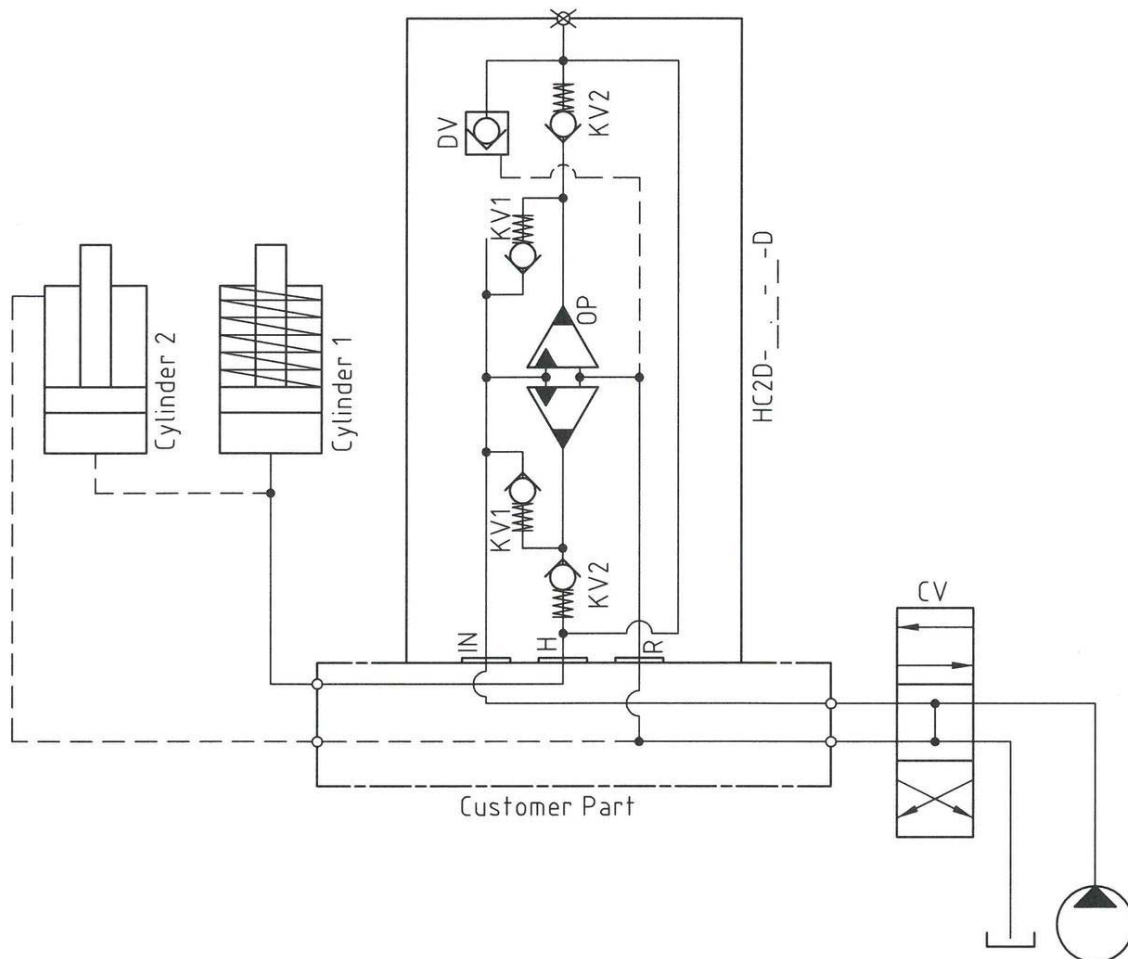

2D-107-00

Fluids and materials

Please see: General specifications

Ordering an HC2D- D

Ordering example of an HC2D- D with i = 4.0, DV incorporated: HC2D - 4.0 - B - D

Model	Intensification, <i>i</i>	Dump valve	Connections
HC2D	- your selection... see flow rate table	- your selection... A = (no) / A model B = (yes) / B model G = (proportional) / G model	- D

