

The Drive & Control Company

Rexroth
Bosch Group

Hydraulic cylinders for explosive areas

Series CDH2...XC / CGH2...XC / CSH2...XE

RE 17335-X

Edition: 2014-03

Replaces: 17334-X/07.12

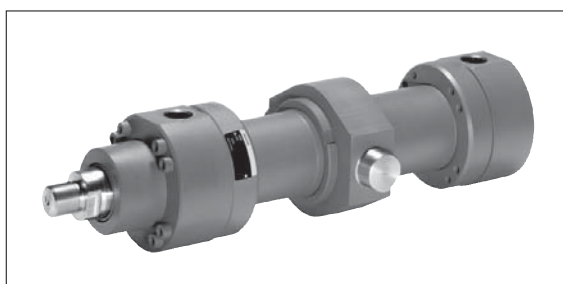

- ▶ Series H2
- ▶ Component series 3X
- ▶ Nominal pressure 250 bar [25 MPa]



Features

- ▶ Standards: DIN 24333, ISO 6022
- ▶ 6 types of mounting
- ▶ Piston Ø (**ØAL**): 40 ... 320 mm
- ▶ Piston rod Ø (**ØMM**): 25 ... 220 mm
- ▶ Stroke lengths up to 6 m

Contents

Features	1
Ordering code: Series CDH2...XC	2, 3
Ordering code: Series CGH2...XC	4, 5
Ordering code: Series CSH2...XE	6, 7
Technical data	8 ... 10
Diameters, areas, forces, flow	11
Tolerances according to ISO 6020-1	11
Overview types of mounting: Series CDH2...XC	12
Overview types of mounting: Series CGH2...XC	12
Overview types of mounting: Series CSH2...XE	13
Dimensions CDH2...XC, CGH2...XC	14 ... 25
Dimensions CSH2...XE	26 ... 37
Flange ports	38, 39
Bleeding/measuring coupling	40
Position measurement system	41, 42
Name plate	43
Equipotential bonding	44, 45
Mounting elements	46 ... 55
Kinking, admissible stroke length	56 ... 58
End position cushioning	59 ... 61
Selection criteria for seals	62
Seal kits	63 ... 66
Tightening torques	67
Spare parts drawing	68 ... 71
Cylinder weight	72
EC Declaration of Conformity	73

Bosch Rexroth AG, RE 17335, edition: 2014-03

2/74 CDH2...XC / CGH2...XC / CSH2...XE | Hydraulic cylinders for explosive areas

Ordering code: Series CDH2...XC

01	02	03	04	05	06	07	08	09	10	11	12	13	14	15	16
CD	H2	/	/	/			XC	3X	/						

01	Differential cylinder	CD
----	-----------------------	-----------

02	Series	H2
----	--------	-----------

Types of mounting

03	Swivel eye at base	MP3
	Self-aligning clevis at base	MP5
	Round flange at head	MF3
	Round flange at base	MF4
	Trunnion	MT4 ²⁾
	Foot mounting	MS2 ¹⁸⁾

04	Piston Ø (ØAL) 40 ... 320 mm	...
----	---------------------------------------	-----

05	Piston rod Ø (ØMM) 25 ... 220 mm	...
----	---	-----

06	Stroke length in mm ³⁾	...
----	-----------------------------------	-----

Protection class for ATEX version

07	Design safety	XC
----	---------------	-----------

08	Component series 30 ... 39 (30 ... 39: Unchanged installation and connection dimensions)	3X
----	--	-----------

Line connection/version

09	According to ISO 1179-1 (pipe thread ISO 228-1)	B
	According to ISO 9974-1 (metric thread ISO 261)	M ³³⁾
	Flange porting pattern according to ISO 6162-1 tab. 2 type 1 (≠ SAE 3000 PSI)	F ^{4; 21)}
	Flange porting pattern according to ISO 6162-2 tab. 2 type 1 (≠ SAE 6000 PSI)	D ^{4; 9)}
	Flange porting pattern according to ISO 6164 tab. 1	K ^{1; 4)}
	Flange porting pattern according to ISO 6164 tab. 2	H ⁴⁾

Line connection/position at head

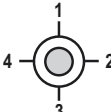
10	View to piston rod		1 ³⁰⁾
			2 ³⁰⁾
			3 ³⁰⁾
			4 ³⁰⁾

Line connection/position at base

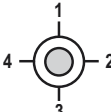
11	View to piston rod		1 ³⁰⁾
			2 ³⁰⁾
			3 ³⁰⁾
			4 ³⁰⁾

Piston rod design

12	Hard chromium-plated	C
	Hardened and hard chromium-plated	H ²³⁾
	Nickel-plated and hard chromium-plated	N ²⁴⁾

Piston rod end

13	Thread for swivel head CGKD	H
	With mounted swivel head CGKD	F

Bosch Rexroth AG, RE 17335, edition: 2014-03

Hydraulic cylinders for explosive areas | **CDH2...XC / CGH2...XC / CSH2...XE** 3/74

Ordering code: Series CDH2...XC

01	02	03	04	05	06	07	08	09	10	11	12	13	14	15	16
CD	H2		/		/		XC	3X	/						

End position cushioning

14	Without end position cushioning	U
	Both sides, self-adjusting	D ¹⁾
	Both sides, adjustable	E

Seal design

15	For mineral oil HL, HLP and HFA	Standard seal system	M
	For mineral oil HL, HLP, HFA and water glycol HFC	Servo quality/reduced friction	T
		Chevron seal kits	A
	For phosphate ester HFD-R	Servo quality/reduced friction	S
Chevron seal kits		B	

Option

16	Additional options, fill fields for additional options	Z
	Without additional options, do not fill fields for additional options	W

Additional options

Fields for additional options

		17	18	19	20	21
	Z	W				

17	Without option	W
18	Additional guide rings	F ¹⁰⁾
	Without additional guide rings	W
19	Measuring coupling, on both sides	A
	Without measuring coupling	W
20	Flanged grease nipple	B
	Standard conical grease nipple	W
21	Specify the piston rod extension LY in the plain text in mm	Y
	Without piston rod extension	W

Order examples:

Without additional options:

CDH2MT4/63/45/350XC3X/B11CHDMWW, XV=300 mm

With additional options:

CDH2MF3/80/56/500XC3X/B11CHDMZ WWAWW

- 1) Only piston Ø 40 to 200 mm
- 2) Trunnion position freely selectable.
When ordering, always specify the "XV" dimensions in the plain text in mm
- 3) Observe the max. stroke length available, page 11, and the admissible stroke length (according to kinking calculation) on pages 56 to 58
- 4) Not possible with MF4
- 9) Only piston Ø 80 to 320 mm
- 10) Seal design A, B not possible;
piston Ø 220 to 320 mm standard
- 18) Not standardized

- 21) Only piston Ø 63 to 200 mm
- 23) Only piston rod Ø 25 to 140 mm
- 24) Only piston rod Ø 28 to 160 mm
- 30) All graphical representations in the data sheet show position 1
- 33) Version does not comply with ISO 6022

RE 17335-X, edition: 2014-03, **Bosch Rexroth AG**

4/74 CDH2...XC / CGH2...XC / CSH2...XE | Hydraulic cylinders for explosive areas

Ordering code: Series CGH2...XC

01	02	03	04	05	06	07	08	09	10	11	12	13	14	15	16
CG	H2	/	/	/	/	X	C	3	X	/					

01	Double-acting cylinders	CG
----	-------------------------	-----------

02	Series	H2
----	--------	-----------

Types of mounting

03	Round flange at head	MF3
	Trunnion	MT4 ²⁾
	Foot mounting	MS2

04	Piston Ø (ØAL) 40 ... 320 mm	...
----	---------------------------------------	-----

05	Piston rod Ø (ØMM) 25 ... 220 mm	...
----	---	-----

06	Stroke length in mm ³⁾	...
----	-----------------------------------	-----

Protection class for ATEX version

07	Design safety	XC
----	---------------	-----------

08	Component series 30 ... 39 (30 ... 39: Unchanged installation and connection dimensions)	3X
----	--	-----------

Line connection/version

09	According to ISO 1179-1 (pipe thread ISO 228-1)	B
	According to ISO 9974-1 (metric thread ISO 261)	M ³³⁾
	Flange porting pattern according to ISO 6162-1 tab. 2 type 1 (≠ SAE 3000 PSI)	F ²¹⁾
	Flange porting pattern according to ISO 6162-2 tab. 2 type 1 (≠ SAE 6000 PSI)	D ⁹⁾
	Flange porting pattern according to ISO 6164 tab. 1	K ¹⁾
	Flange porting pattern according to ISO 6164 tab. 2	H

Line connection/position at head

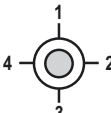
10	View to piston rod		1 ³⁰⁾
			2 ³⁰⁾
			3 ³⁰⁾
			4 ³⁰⁾

Line connection/position at base

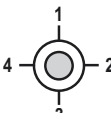
11	View to piston rod		1 ³⁰⁾
			2 ³⁰⁾
			3 ³⁰⁾
			4 ³⁰⁾

Piston rod design

12	Hard chromium-plated	C
	Hardened and hard chromium-plated	H ²³⁾

Piston rod end

13	Thread for swivel head CGKD	H
	With mounted swivel head CGKD	F ¹⁷⁾

End position cushioning

14	Without end position cushioning	U
	Both sides, self-adjusting	D ¹⁾
	Both sides, adjustable	E

Bosch Rexroth AG, RE 17335, edition: 2014-03

Ordering code: Series CGH2...XC

01	02	03	04	05	06	07	08	09	10	11	12	13	14	15	16
CG	H2		/		/		X	C	3	X	/				

Seal design

15	For mineral oil HL, HLP and HFA	Standard seal system	M
	For mineral oil HL, HLP, HFA and water glycol HFC	Servo quality/reduced friction	T
		Chevron seal kits	A
	For phosphate ester HFD-R	Servo quality/reduced friction	S
Chevron seal kits		B	

Option

16	Additional options, fill fields for additional options	Z
	Without additional options, do not fill fields for additional options	W

Additional options

Fields for additional options

	17	18	19	20	21
Z	W				

17	Without option	W
18	Additional guide rings	F ¹⁰⁾
	Without additional guide rings	W
19	Measuring coupling, on both sides	A
	Without measuring coupling	W
20	Flanged grease nipple	B
	Standard conical grease nipple	W
21	Specify the piston rod extension LY in the plain text in mm	Y ¹⁶⁾
	Without piston rod extension	W

Order examples:

Without additional options:

CGH2MF3/100/70/500XC3X/B11CHUMWW

With additional options:

CGH2MF3/100/70/500XC3X/B11CHUMZ WWAWW

- 1) Only piston Ø 40 to 200 mm
- 2) Trunnion position freely selectable.
When ordering, always specify the "XV" dimensions in the plain text in mm
- 3) Observe the max. stroke length available, page 11, and the admissible stroke length (according to kinking calculation) on pages 56 to 58
- 9) Only piston Ø 80 to 320 mm
- 10) Seal design A, B not possible; piston Ø 220 to 320 mm standard
- 16) Only at left piston rod side (orientation: Catalog figures)
- 17) Only one plain clevis/swivel head mounted, left piston rod side (orientation: Catalog figures)
- 18) Not standardized
- 21) Only piston Ø 63 to 200 mm
- 23) Only piston rod Ø 25 to 140 mm
- 30) All graphical representations in the data sheet show position 1
- 33) Version does not comply with ISO 6022

6/74 CDH2...XC / CGH2...XC / CSH2...XE | Hydraulic cylinders for explosive areas

Ordering code: Series CSH2...XE

01	02	03	04	05	06	07	08	09	10	11	12	13	14	15	16
CS	H2	/	/	/			XE	3X	/						Z

01	Differential cylinder with position measurement system	CS ¹⁸⁾
----	--	-------------------

02	Series	H2
----	--------	----

Types of mounting

03	Swivel eye at base	MP3
	Self-aligning clevis at base	MP5
	Round flange at head	MF3
	Round flange at base	MF4
	Trunnion	MT4 ²⁾
	Foot mounting	MS2

04	Piston Ø (ØAL) 40 ... 320 mm	...
----	------------------------------	-----

05	Piston rod Ø (ØMM) 28 ... 220 mm	...
----	----------------------------------	-----

06	Stroke length in mm ³⁾	...
----	-----------------------------------	-----

Protection class for ATEX version

07	Increased safety	XE
----	------------------	----

08	Component series 30 ... 39 (30 ... 39: Unchanged installation and connection dimensions)	3X
----	--	----

Line connection/version

09	According to ISO 1179-1 (pipe thread ISO 228-1)	B
	According to ISO 9974-1 (metric thread ISO 261)	M ³³⁾
	Flange porting pattern according to ISO 6162-1 tab. 2 type 1 (≙ SAE 3000 PSI)	F ^{4; 21)}
	Flange porting pattern according to ISO 6162-2 tab. 2 type 1 (≙ SAE 6000 PSI)	D ^{4; 9)}
	Flange porting pattern according to ISO 6164 tab. 1	K ^{1; 4)}
	Flange porting pattern according to ISO 6164 tab. 2	H ⁴⁾

Line connection/position at head

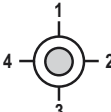
10	View to piston rod		1 ³⁰⁾
			2 ³⁰⁾
			3 ³⁰⁾
			4 ³⁰⁾

Line connection/position at base

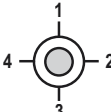
11	View to piston rod		1 ³⁰⁾
			2 ³⁰⁾
			3 ³⁰⁾
			4 ³⁰⁾

Piston rod design

12	Hard chromium-plated	C
	Nickel-plated and hard chromium-plated	N ¹⁹⁾

Piston rod end

13	Thread for swivel head CGKD	H
	With mounted swivel head CGKD	F

Ordering code: Series CSH2...XE

01	02	03	04	05	06	07	08	09	10	11	12	13	14	15	16
CS	H2		/		/		XE	3X	/						Z

End position cushioning

14	Without end position cushioning	U
	Both sides, adjustable	E ²⁰⁾

Seal design

15	For mineral oil HL, HLP and HFA	Standard seal system	M ²⁹⁾
	For mineral oil HL, HLP, HFA and water glycol HFC	Servo quality/reduced friction	T ²⁹⁾
	For phosphate ester HFD-R	Servo quality/reduced friction	S ²⁹⁾

Option

16	Additional options, fill fields for additional options	Z
----	--	---

Additional options

Fields for additional options

	17	18	19	20	21
Z	T				

17	Position measurement system (magnetostrictive) without mating connector, mating connector – separate order, see page 41	T
18	Analog output 4 ... 20 mA	C
	Analog output 0 ... 10 V	F
	Digital output SSI	D
19	Measuring coupling, on both sides	A
	Without measuring coupling	W
20	Flanged grease nipple	B
	Standard conical grease nipple	W
21	Specify the piston rod extension LY in the plain text in mm	Y
	Without piston rod extension	W

Order example:

CSH2MP5/100/70/500XE3X/B11CHUTZ TFABW

- | | |
|---|---|
| 1) Only piston Ø 40 to 200 mm | 20) Possible from piston rod Ø 45 mm |
| 2) Trunnion position freely selectable.
When ordering, always specify the "XV" dimensions in the plain text in mm | 21) Only piston Ø 63 to 200 mm |
| 3) Observe the max. stroke length available, page 11, and the admissible stroke length (according to kinking calculation) on pages 56 to 58 | 29) With CSH2...XE, by default with guide belts |
| 4) Not possible with MF4 | 30) All graphical representations in the data sheet show position 1 |
| 9) Only piston Ø 80 to 320 mm | 33) Version does not comply with ISO 6022 |
| 18) Not standardized | |
| 19) Only piston rod Ø 28 mm to 160 mm | |

8/74 CDH2...XC / CGH2...XC / CSH2...XE | Hydraulic cylinders for explosive areas

Technical data

(For applications outside these parameters, please consult us!)

ATEX units for explosive areas

What you need to know about the documentation for ATEX units.

The documentation for ATEX units applies to the explosion-proof version of Bosch Rexroth hydraulic cylinders and consists of the following two parts with the material no. R901029463:

- ▶ Operating instructions 07100-B/03.11 for hydraulic cylinders tie rod design/mill type, mill type for explosive areas
- ▶ Technical data sheet 17335-X

You can find further information on the correct handling of hydraulic products in our publication "General product information on hydraulic products" 07008.

Information on the explosion protection:

- ▶ Cylinders without position measurement system
 - Marking according to directive 94/9/EC II 2G c T4
 - Marking according to directive 94/9/EC II 2D c T135 °C
 - Ambient temperature $-20\text{ °C} \leq T_a \leq +80\text{ °C}$
- ▶ Cylinders with position measurement system
 - Marking according to directive 94/9/EC II 3G Ex e T4
 - Marking according to directive 94/9/EC II 3D Ex tc T135 °C
 - Ambient temperature $-20\text{ °C} \leq T_a \leq +70\text{ °C}$

general		
Weight	kg	See page 72
Installation position		Any
Ambient temperature range	°C	See page 62
Primer coat ¹⁾	µm	Min. 40

hydraulic		
Nominal pressure ²⁾	bar [MPa]	250 [25]
Minimum operating pressure ³⁾ (without load)	bar [MPa]	10 [1]
Static test pressure	bar [MPa]	375 [37.5]
Reduced test pressure	bar [MPa]	315 [31.5]
Hydraulic fluid		See table below
Hydraulic fluid temperature range	°C	See page 62
Viscosity range	mm ² /s	12 ... 380
Maximum admissible degree of contamination of the hydraulic fluid - cleanliness class according to ISO 4406 (c)		Class 20/18/15 ⁴⁾
Stroke speed ⁵⁾ (depending on line connection)	m/s	See table on page 9
Bleeding		By default secured against screwing out

Hydraulic fluid	Classification	Suitable sealing materials	Standards
Mineral oils	HL, HLP	NBR, FKM	DIN 51524
Oil-in-water emulsion	HFA	NBR, FKM	DIN 51524
Flame-resistant	– water-free – containing water	HFDR HFC	FKM Upon request

Bosch Rexroth AG, RE 17335, edition: 2014-03

Technical data

(For applications outside these parameters, please consult us!)

Stroke velocity

Piston Ø in mm	Line connection	Max. stroke velocity in m/s
40	G1/2	0.31
50	G1/2	0.20
63	G3/4	0.28
80	G3/4	0.18
100	G1	0.20
125	G1	0.13
140	G1 1/4	0.16

Piston Ø in mm	Line connection	Max. stroke velocity in m/s
160	G1 1/4	0.12
180	G1 1/4	0.10
200	G1 1/4	0.08
220	G1 1/2	0.09
250	G1 1/2	0.07
280	G1 1/2	0.06
320	G1 1/2	0.04

¹⁾ By default, hydraulic cylinders are primed with a coating (color gentian blue RAL 5010). Other colors upon request. With cylinders and attachment parts, the following surfaces are not primed or painted:

- ▶ All fit diameters to the customer side
- ▶ Sealing surfaces for line connection
- ▶ Sealing surfaces for flange connection
- ▶ Position measurement system

The areas that are not painted are protected by means of a solvent-free corrosion protection agent.

²⁾ Higher operating pressures upon request

The specified operating pressures apply to applications with shock-free operation with regard to excess pressure and/or external loads. With extreme loads like e.g. high sequence cycle, mounting elements and threaded piston rod connections must be designed for durability.

³⁾ Depending on the application, a certain minimum pressure is required in order to guarantee good functioning of the cylinder.

Without load, a minimum pressure of 10 bar is recommended for differential cylinders; for lower pressures as well as double-acting cylinders, please contact us.

⁴⁾ The cleanliness classes specified for the components must be adhered to in hydraulic systems. Effective filtration prevents faults and at the same time increases the life cycle of the components.

For the selection of the filters see www.boschrexroth.com/filter.

⁵⁾ Please observe the guideline on max. stroke velocities (with recommended flow velocity of 5 m/s in the line connection) in the table. Higher stroke velocities on request.

If the extension velocity is considerably higher than the retraction velocity of the piston rod, drag-out losses of the medium may result. If necessary, please consult us.

10/74 CDH2...XC / CGH2...XC / CSH2...XE | Hydraulic cylinders for explosive areas

Technical data

(For applications outside these parameters, please consult us!)

Life cycle:

Rexroth cylinders correspond to the reliability recommendations for industrial applications.

≥ 10 000 000 double strokes in idle continuous operation or 3000 km piston travel at 70 % of the maximum operating pressure, without load on the piston rod, with a maximum velocity of 0.5 m/s, with a failure rate of less than 5 %.

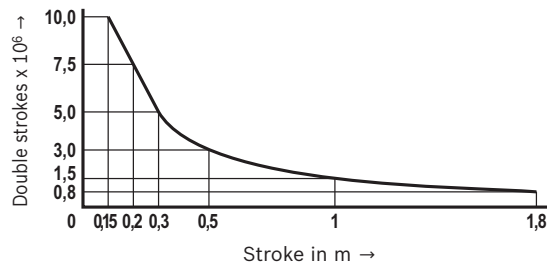

Notice!

Boundary and application conditions:

- ▶ The mechanical alignment of the movement axis and thus the mounting points of hydraulic cylinder and piston rod must be ensured. Lateral forces on the guides of piston rod and piston are to be avoided. It may be necessary to consider the own weight of the hydraulic cylinder (MP3/MP5 or MT4) or the piston rod.
- ▶ The kinking length/kinking load of the piston rod and/or the hydraulic cylinder must be observed (see page topic Kinking).
- ▶ The maximum admissible stroke velocities with regard to the suitability/load of seals must be observed as must their compatibility with the properties of the fluid type (see page topic Seals).
- ▶ The maximum admissible velocities/kinetic energies when moving into the end positions, also considering external loads, must be observed.
Danger: Excess pressure
- ▶ The maximum admissible operating pressure must be complied with in any operating state of the hydraulic cylinder.
Possible pressure intensification resulting from the area ratio of annulus area to piston area and possible throttling points are to be observed.
- ▶ Detrimental environmental influences, like e.g. aggressive finest particles, vapors, high temperatures, etc. as well as contaminations and deterioration of the hydraulic fluid are to be avoided.

Standards:

The installation dimensions and types of mounting of the cylinder comply with the standards DIN 24333 and ISO 6022.

Acceptance:

Each cylinder is tested according to Bosch Rexroth standard and in compliance with ISO 10100: 2001.

Safety instructions:

For the assembly, commissioning and maintenance of hydraulic cylinders, the operating instructions 07100-B have to be observed!

Service and repair work has to be performed by Bosch Rexroth AG or by personnel especially trained for this purpose. No warranty is accepted for damage as a consequence of assembly, maintenance or repair work not performed by Bosch Rexroth AG.

Check lists for hydraulic cylinders:

Cylinders the characteristics and/or application parameters of which deviate from the values specified in the data sheet can only be offered as special version upon request. For offers, the deviations of the characteristics and/or application parameters must be described in the check lists for hydraulic cylinders (07200).

This list does not claim to be complete. In case of questions regarding the compatibility with media or exceedance of the boundary or application conditions, please contact us.

Diameters, areas, forces, flow

Piston ØAL mm	Piston rod ØMM mm	Area ratio ϕ A_1/A_3	Areas			Force at 250 bar ¹⁾			Flow at 0.1 m/s ²⁾			Max. available stroke length mm
			Piston A_1 cm ²	Rod A_2 cm ²	Ring A_3 cm ²	Pressure F_1 kN	Diff. F_2 kN	Pulling F_3 kN	Off q_{v1} l/min	Diff. q_{v2} l/min	On q_{v3} l/min	
40	25	1.64	12.56	4.90	7.65	31.40	12.25	19.12	7.5	2.9	4.6	2000
	28	1.96		6.16						6.40		
50	32	1.69	19.63	8.04	11.59	49.10	20.12	28.98	11.8	4.8	7.0	2000
	36	2.08		10.18						9.45		
63	40	1.67	31.17	12.56	18.61	77.90	31.38	46.52	18.7	7.5	11.2	2000
	45	2.04		15.90						15.27		
80	50	1.66	50.26	19.63	30.63	125.65	49.07	76.58	30.2	11.8	18.4	2000
	56	1.96		24.63						25.63		
100	63	1.66	78.54	31.16	47.38	196.35	77.93	118.42	47.1	18.7	28.4	3000
	70	1.96		38.48						40.06		
125	80	1.69	122.72	50.24	72.48	306.75	125.62	181.13	73.6	30.1	43.5	3000
	90	2.08		63.62						59.10		
140	90	1.70	153.94	63.62	90.32	384.75	159.05	225.70	92.4	38.2	54.2	3000
	100	2.04		78.54						75.40		
160	100	1.64	201.06	78.54	122.50	502.50	196.35	306.15	120.6	47.1	73.5	3000
	110	1.90		95.06						106.00		
180	110	1.60	254.47	95.06	159.43	636.17	237.65	398.52	152.7	57.0	95.7	3000
	125	1.93		122.72						131.75		
200	125	1.64	314.16	122.72	191.44	785.25	306.80	478.45	188.5	73.6	114.9	3000
	140	1.96		153.96						160.20		
220	140	1.68	380.1	153.96	226.2	950.3	384.9	565.5	228.1	92.4	135.7	6000
	160	2.12		201.0						179.1		
250	160	1.69	490.8	201.0	289.8	1227.2	502.6	724.5	294.5	120.7	173.8	6000
	180	2.08		254.4						236.4		
280	180	1.70	615.7	254.4	361.3	1539.4	636.2	903.2	369.4	152.7	216.7	6000
	200	2.04		314.1						301.6		
320	200	1.64	804.2	314.1	490.1	2010.6	785.4	1225.2	482.5	188.5	294.0	6000
	220	1.90		380.1						424.2		

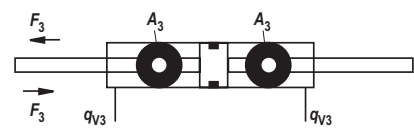
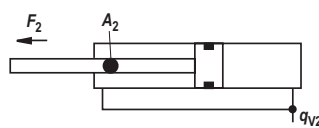
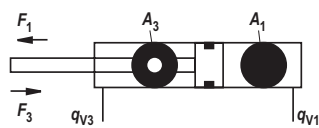

¹⁾ Theoretical static cylinder force
(without consideration of the efficiency and admissible load for attachment parts like e.g. swivel heads, plates or valves, etc.)

²⁾ Stroke speed

Tolerances according to ISO 6020-1

Installation dimensions	WC	XC ²⁾	XO ²⁾	XS ^{1), 2)}	XV ²⁾	ZP ²⁾	Stroke tolerances
Type of mounting	MF3	MP3	MP5	MS2	MT4	MF4	
Stroke length	Tolerances						
≤ 1250	±2	±1.5	±1.5	±2	±2	±1.5	+2
> 1250 – ≤ 3150	±4	±3	±3	±4	±4	±3	+5
> 3150 – ≤ 6000	±8	±5	±5	±8	±8	±5	+8

¹⁾ Not standardized

²⁾ Including stroke length

12/74 CDH2...XC / CGH2...XC / CSH2...XE | Hydraulic cylinders for explosive areas

Overview types of mounting: Series CDH2...XC

CDH2...XC: MP3

See page 14, 15



CDH2...XC: MF4

See page 20, 21



CDH2...XC: MP5

See page 16, 17



CDH2...XC: MT4

See page 22, 23



CDH2...XC: MF3

See page 18, 19



CDH2...XC: MS2

See page 24, 25



Overview types of mounting: Series CGH2...XC

CGH2...XC: MF3

See page 18, 19



CGH2...XC: MS2

See page 24, 25

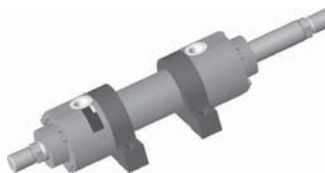

CGH2...XC: MT4

See page 22, 23



Bosch Rexroth AG, RE 17335, edition: 2014-03

Overview types of mounting: Series CSH2...XE

CSH2...XE: MP3

See page 26, 27



CSH2...XE: MF4

See page 32, 33

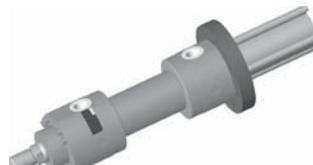

CSH2...XE: MP5

See page 28, 29



CSH2...XE: MT4

See page 34, 35



CSH2...XE: MF3

See page 30, 31



CSH2...XE: MS2

See page 36, 37

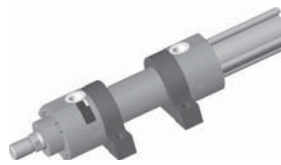

14/74 CDH2...XC / CGH2...XC / CSH2...XE | Hydraulic cylinders for explosive areas

Dimensions: Swivel eye at base CDH2...XC: MP3

(dimensions in mm)

CDH2...XC: MP3

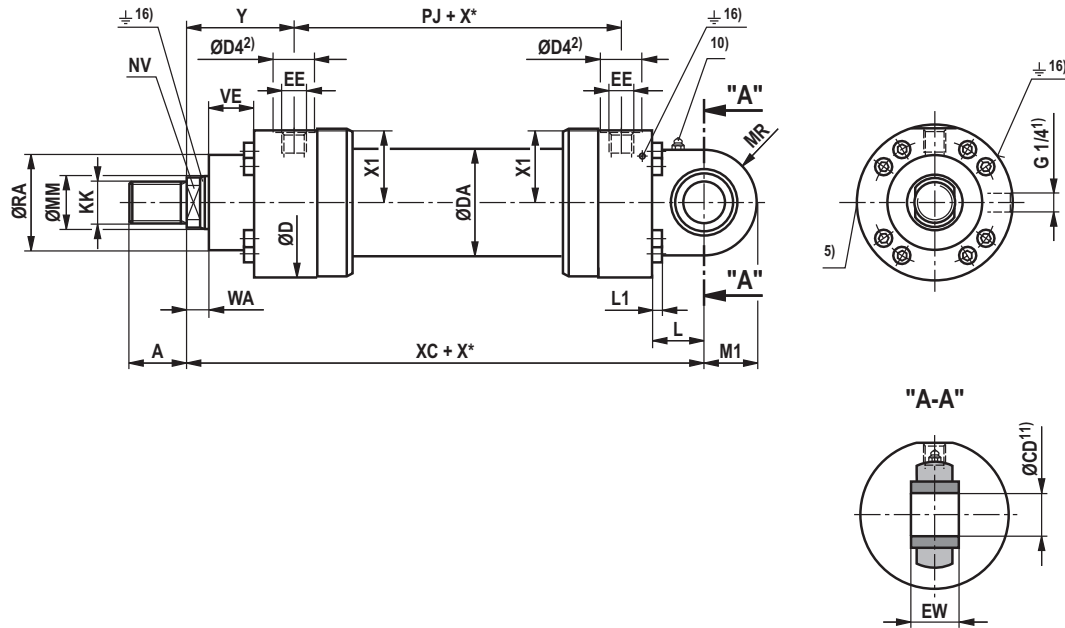

CDH2...XC: MP3: With seal design "A", "B" and AL Ø 160 ... 320 mm

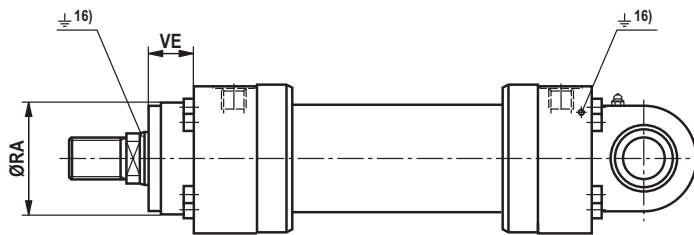

Bosch Rexroth AG, RE 17335, edition: 2014-03

Dimensions: Swivel eye at base CDH2...XC: MP3
(dimensions in mm)

ØAL	ØMM	KK	A	NV	ØD	ØDA	ØD4 ²⁾	EE ⁴⁾	EE ⁴⁾	Y	PJ	X1	WA	XC
40 ⁶⁾	25/28	M20x1.5	28	19/22	88	52	34	G1/2	M22x1.5	83	120	41	18	282
50	32/36	M27x2	36	27/30	102	62	34	G1/2	M22x1.5	98	120	48.5	18	305
63	40/45	M33x2	45	32/36	120	78	42	G3/4	M27x2	112	133	56.5	21	348
80	50/56	M42x2	56	41/46	145	95	42	G3/4	M27x2	120	155	69.5	24	395
100	63/70	M48x2	63	50/60	170	125	47	G1	M33x2	134	171	82	27	442
125	80/90	M64x3	85	65/75	206	150	47	G1	M33x2	153	205	100.5	31	520
140	90/100	M72x3	90	75/85	226	170	58	G1 1/4	M42x2	166	219	109.5	31	580
160	100/110	M80x3	95	85/95	265	190	58	G1 1/4	M42x2	185	235	129.5	35	617
180	110/125	M90x3	105	95/110	292	210	58	G1 1/4	M42x2	194	264	143.5	40	690
200	125/140	M100x3	112	110/120	306	235	58	G1 1/4	M42x2	220	278	150.5	40	756
220 ⁶⁾	140/160	M125x4	125	120/140	355	270	65	G1 1/2	M48x2 ³⁾	244	326	174	42	890
250	160/180	M125x4	125	140/160	395	305	65	G1 1/2	M48x2 ³⁾	257	326	194	42	903
280 ⁶⁾	180/200	M160x4	160	160/180	445	343	65	G1 1/2	M48x2 ³⁾	290	375	220.5	48	1072
320	200/220	M160x4	160	180/200	490	394	65	G1 1/2	M48x2 ³⁾	282	391	243	48	1080

ØAL	ØMM	L	L1	MR	M1	ØCD ^{H9}	EW ^{h12}	ØRA ⁷⁾	VE ⁷⁾	ØRA ⁸⁾	VE ⁸⁾
40 ⁶⁾	25/28	53	8	32	32	25	25	52	29	88	-
50	32/36	61	8	40	40	32	32	63	29	102	-
63	40/45	74	8	50	50	40	40	75	32	120	-
80	50/56	90	10	63	63	50	50	90	36	145	-
100	63/70	102	12	71	71	63	63	110	41	170	-
125	80/90	124	16	90	90	80	80	132	45	206	-
140	90/100	149	16	100	100	90	90	145	45	226	-
160	100/110	150	16	112	112	100	100	160	50	200	50
180	110/125	180	20	129	129	110	110	185	55	220	55
200	125/140	206	20	145	145	125	125	200	61	235	61
220 ⁶⁾	140/160	253	20	179 ¹²⁾	187 ¹²⁾	160	160	235	71	270	71
250	160/180	253	24	179 ¹²⁾	187 ¹²⁾	160	160	250	71	300	71
280 ⁶⁾	180/200	320	30	230 ¹²⁾	240 ¹²⁾	200	200	295	88	325	88
320	200/220	320	30	231 ¹²⁾	241 ¹²⁾	200	200	320	88	365	88

ØAL = Piston Ø

ØMM = Piston rod Ø

X* = Stroke length

1) Bleeding: With view to the piston rod, the position is offset by 90° in relation to the line connection (clockwise)

2) Ø D4 max. 0.5 mm deep

3) Thread size does not correspond to ISO 6022; M50 x 2 available upon request

4) Flange connections see separate table pages 38 and 39

5) Throttle valve only with end position cushioning "E" (180° for bleeding)

6) Piston Ø not standardized

7) Dimensions for cylinders with seal design M, T, and S

8) Dimensions for cylinders with seal design A and B

10) Standard version "W" Lubricating nipple, cone head form A according to DIN 71412

11) Related bolt Ø f8

12) The specified dimensions are maximum values, tolerance classes 342 according to ISO 9013 Thermal cutting

16) Equipotential bonding see pages 44 and 45

16/74 CDH2...XC / CGH2...XC / CSH2...XE | Hydraulic cylinders for explosive areas

Dimensions: Self-aligning clevis at base CDH2...XC: MP5

(dimensions in mm)

CDH2...XC: MP5

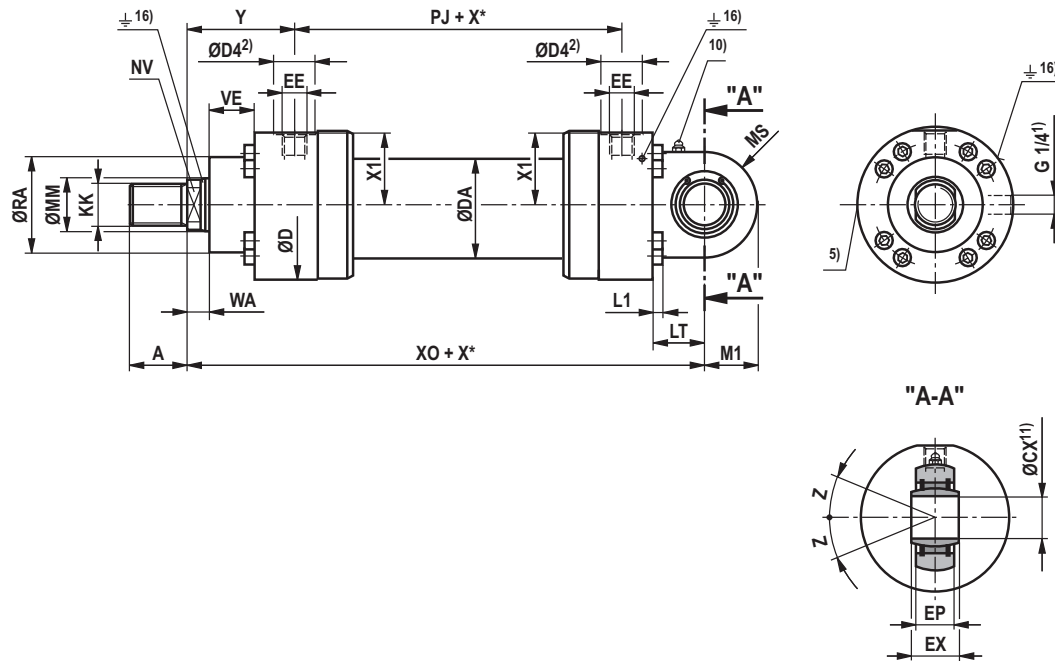

CDH2...XC: MP5: With seal design "A", "B" and AL Ø 160 ... 320 mm

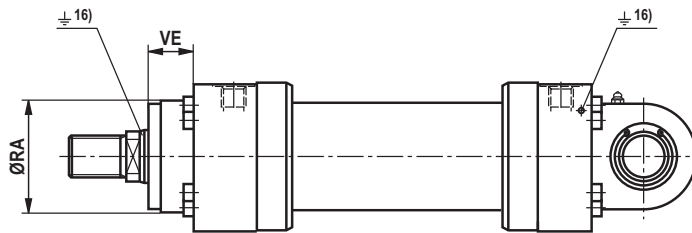

Bosch Rexroth AG, RE 17335, edition: 2014-03

Hydraulic cylinders for explosive areas | **CDH2...XC / CGH2...XC / CSH2...XE** 17/74

Dimensions: Self-aligning clevis at base CDH2...XC: MP5
(dimensions in mm)

ØAL	ØMM	KK	A	NV	ØD	ØDA	ØD4 ²⁾	EE ⁴⁾	EE ⁴⁾	Y	PJ	X1	WA	XO
40 ⁶⁾	25/28	M20x1.5	28	19/22	88	52	34	G1/2	M22x1.5	83	120	41	18	282
50	32/36	M27x2	36	27/30	102	62	34	G1/2	M22x1.5	98	120	48.5	18	305
63	40/45	M33x2	45	32/36	120	78	42	G3/4	M27x2	112	133	56.5	21	348
80	50/56	M42x2	56	41/46	145	95	42	G3/4	M27x2	120	155	69.5	24	395
100	63/70	M48x2	63	50/60	170	125	47	G1	M33x2	134	171	82	27	442
125	80/90	M64x3	85	65/75	206	150	47	G1	M33x2	153	205	100.5	31	520
140	90/100	M72x3	90	75/85	226	170	58	G1 1/4	M42x2	166	219	109.5	31	580
160	100/110	M80x3	95	85/95	265	190	58	G1 1/4	M42x2	185	235	129.5	35	617
180	110/125	M90x3	105	95/110	292	210	58	G1 1/4	M42x2	194	264	143.5	40	690
200	125/140	M100x3	112	110/120	306	235	58	G1 1/4	M42x2	220	278	150.5	40	756
220 ⁶⁾	140/160	M125x4	125	120/140	355	270	65	G1 1/2	M48x2 ³⁾	244	326	174	42	890
250	160/180	M125x4	125	140/160	395	305	65	G1 1/2	M48x2 ³⁾	257	326	194	42	903
280 ⁶⁾	180/200	M160x4	160	160/180	445	343	65	G1 1/2	M48x2 ³⁾	290	375	220.5	48	1072
320	200/220	M160x4	160	180/200	490	394	65	G1 1/2	M48x2 ³⁾	282	391	243	48	1080

ØAL	ØMM	LT	L1	MS	M1	ØCX ¹¹⁾ H7	EP	EX ^{h12}	ØRA ⁷⁾	VE ⁷⁾	ØRA ⁸⁾	VE ⁸⁾	Z
40 ⁶⁾	25/28	53	8	32	32	25	22	25	52	29	88	–	2°
50	32/36	61	8	40	40	32	27	32	63	29	102	–	4°
63	40/45	74	8	50	50	40	32	40	75	32	120	–	4°
80	50/56	90	10	63	63	50	40	50	90	36	145	–	4°
100	63/70	102	12	71	71	63	52	63	110	41	170	–	4°
125	80/90	124	16	90	90	80	66	80	132	45	206	–	4°
140	90/100	149	16	100	100	90	72	90	145	45	226	–	4°
160	100/110	150	16	112	112	100	84	100	160	50	200	50	4°
180	110/125	180	20	129	129	110	88	110	185	55	220	55	4°
200	125/140	206	20	145	145	125	102	125	200	61	235	61	4°
220 ⁶⁾	140/160	253	20	179 ¹²⁾	187 ¹²⁾	160	130	160	235	71	270	71	4°
250	160/180	253	24	179 ¹²⁾	187 ¹²⁾	160	130	160	250	71	300	71	4°
280 ⁶⁾	180/200	320	30	230 ¹²⁾	240 ¹²⁾	200	138	200	295	88	325	88	4°
320	200/220	320	30	231 ¹²⁾	241 ¹²⁾	200	162	200	320	88	365	88	4°

ØAL = Piston Ø

ØMM = Piston rod Ø

X* = Stroke length

¹⁾ Bleeding: With view to the piston rod, the position is offset by 90° in relation to the line connection (clockwise)

²⁾ Ø D4 max. 0.5 mm deep

³⁾ Thread size does not correspond to ISO 6022; M50 x 2 available upon request

⁴⁾ Flange connections see separate table pages 38 and 39

⁵⁾ Throttle valve only with end position cushioning "E" (180° for bleeding)

⁶⁾ Piston Ø not standardized

⁷⁾ Dimensions for cylinders with seal design M, T, and S

⁸⁾ Dimensions for cylinders with seal design A and B

¹⁰⁾ Standard version "W" Lubricating nipple, cone head form A according to DIN 71412

¹¹⁾ Related bolt Ø f8

¹²⁾ The specified dimensions are maximum values, tolerance classes 342 according to ISO 9013 Thermal cutting

¹⁶⁾ Equipotential bonding see pages 44 and 45

RE 17335-X, edition: 2014-03, **Bosch Rexroth AG**

18/74 CDH2...XC / CGH2...XC / CSH2...XE | Hydraulic cylinders for explosive areas

Dimensions: Round flange at head CDH2...XC / CGH2...XC: MF3

(dimensions in mm)

CDH2...XC: MF3

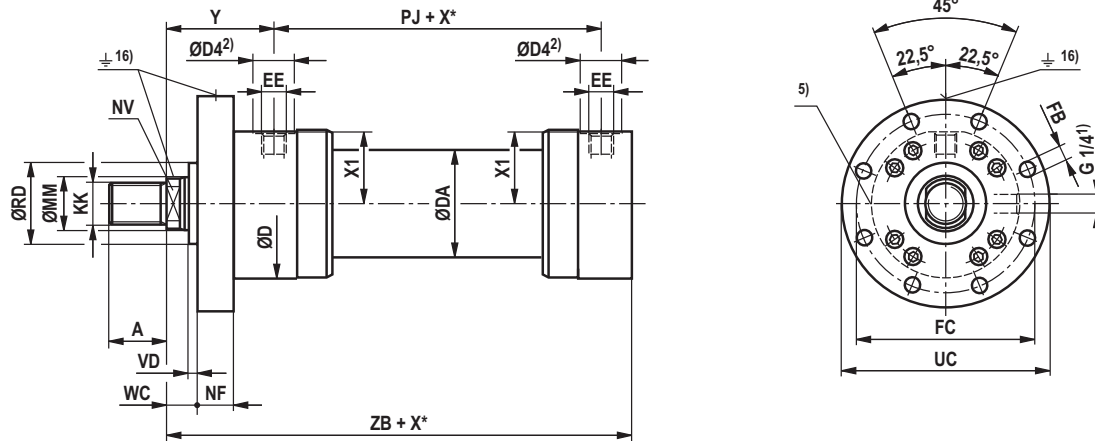

CGH2...XC: MF3 ¹⁰⁾

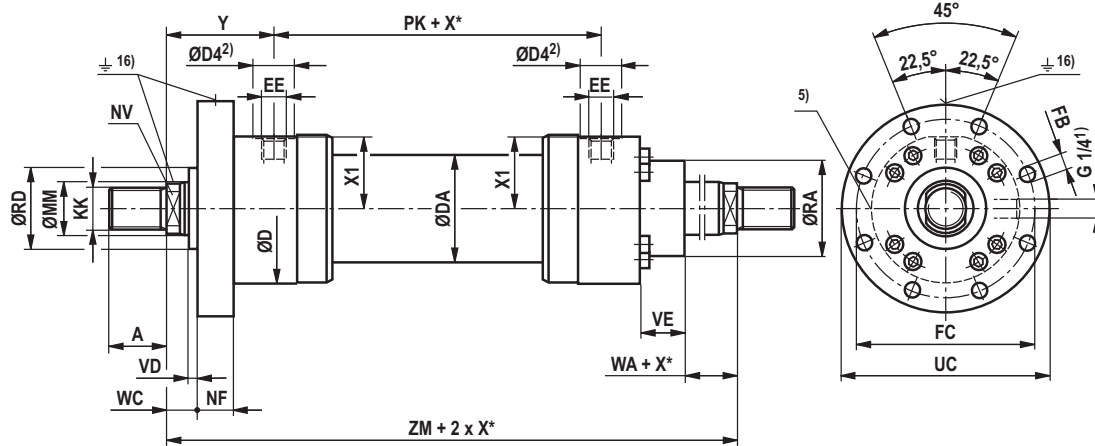

CGH2...XC: MF3 ¹⁰⁾: With seal design "A", "B" and AL Ø 160 ... 320 mm

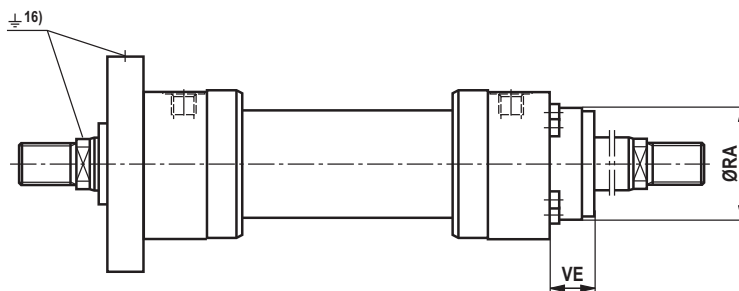

Bosch Rexroth AG, RE 17335, edition: 2014-03

Dimensions: Round flange at head CDH2...XC / CGH2...XC: MF3
(dimensions in mm)

ØAL	ØMM	KK	A	NV	ØD	ØDA	ØD4 ²⁾	EE ⁴⁾	EE ⁴⁾	Y	PJ	X1	WA
40 ⁶⁾	25/28	M20x1.5	28	19/22	88	52	34	G1/2	M22x1.5	83	120	41	18
50	32/36	M27x2	36	27/30	102	62	34	G1/2	M22x1.5	98	120	48.5	18
63	40/45	M33x2	45	32/36	120	78	42	G3/4	M27x2	112	133	56.5	21
80	50/56	M42x2	56	41/46	145	95	42	G3/4	M27x2	120	155	69.5	24
100	63/70	M48x2	63	50/60	170	125	47	G1	M33x2	134	171	82	27
125	80/90	M64x3	85	65/75	206	150	47	G1	M33x2	153	205	100.5	31
140	90/100	M72x3	90	75/85	226	170	58	G1 1/4	M42x2	166	219	109.5	31
160	100/110	M80x3	95	85/95	265	190	58	G1 1/4	M42x2	185	235	129.5	35
180	110/125	M90x3	105	95/110	292	210	58	G1 1/4	M42x2	194	264	143.5	40
200	125/140	M100x3	112	110/120	306	235	58	G1 1/4	M42x2	220	278	150.5	40
220 ⁶⁾	140/160	M125x4	125	120/140	355	270	65	G1 1/2	M48x2 ³⁾	244	326	174	42
250	160/180	M125x4	125	140/160	395	305	65	G1 1/2	M48x2 ³⁾	257	326	194	42
280 ⁶⁾	180/200	M160x4	160	160/180	445	343	65	G1 1/2	M48x2 ³⁾	290	375	220.5	48
320	200/220	M160x4	160	180/200	490	394	65	G1 1/2	M48x2 ³⁾	282	391	243	48

ØAL	ØMM	ØRD f8	WC	VD	NF js13	PK	ZB max.	ZM	ØFB H13	ØFC js13	ØUC -1	ØRA ⁷⁾	VE ⁷⁾	ØRA ⁸⁾	VE ⁸⁾
40 ⁶⁾	25/28	52	22	4	25	120	230	286	11	115	138	52	29	88	-
50	32/36	63	22	4	25	120	244	316	13.5	132	155	63	29	102	-
63	40/45	75	25	4	28	133	274	357	13.5	150	175	75	32	120	-
80	50/56	90	28	4	32	155	305	395	17.5	180	210	90	36	145	-
100	63/70	110	32	5	36	171	340	439	22	212	250	110	41	170	-
125	80/90	132	36	5	40	205	396	511	22	250	290	132	45	206	-
140	90/100	145	36	5	40	219	430	551	26	285	330	145	45	226	-
160	100/110	160	40	5	45	235	467	605	26	315	360	160	50	200	50
180	110/125	185	45	5	50	264	510	652	33	355	410	185	55	220	55
200	125/140	200	45	5	56	278	550	718	33	385	440	200	61	235	61
220 ⁶⁾	140/160	235	50	8	63	326	637	814	39	435	500	235	71	270	71
250	160/180	250	50	8	63	326	650	840	39	475	540	250	71	300	71
280 ⁶⁾	180/200	295	56	8	80	375	752	955	45	555	630	295	88	325	88
320	200/220	320	56	8	80	391	760	955	45	600	675	320	88	365	88

ØAL = Piston Ø

ØMM = Piston rod Ø

X* = Stroke length

¹⁾ Bleeding: With view to the piston rod, the position is offset by 90° in relation to the line connection (clockwise)

²⁾ Ø D4 max. 0.5 mm deep

³⁾ Thread size does not correspond to ISO 6022;
M50 x 2 available upon request

⁴⁾ Flange connections see separate table pages 38 and 39

⁵⁾ Throttle valve only with end position cushioning "E"
(180° for bleeding)

⁶⁾ Piston Ø not standardized

⁷⁾ Dimensions for cylinders with seal design M, T, and S

⁸⁾ Dimensions for cylinders with seal design A and B

¹⁰⁾ Double-acting cylinder not standardized

¹⁶⁾ Equipotential bonding see pages 44 and 45

20/74 CDH2...XC / CGH2...XC / CSH2...XE | Hydraulic cylinders for explosive areas

Dimensions: Round flange at base CDH2...XC: MF4

(dimensions in mm)

CDH2...XC: MF4

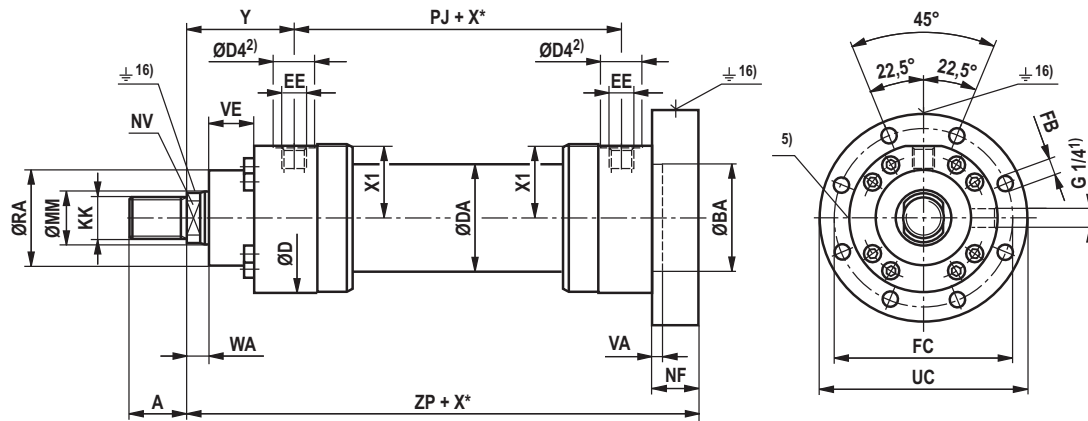

CDH2...XC: MF4 ¹⁰⁾: With seal design "A", "B" and AL Ø 160 ... 320 mm

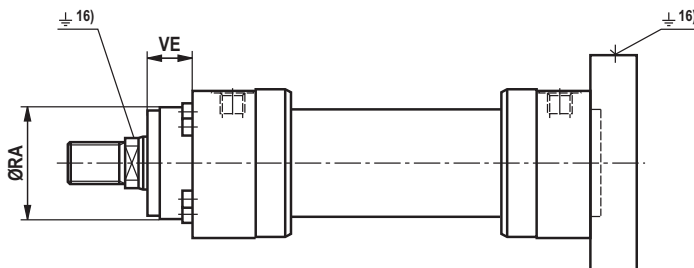

Bosch Rexroth AG, RE 17335, edition: 2014-03

Dimensions: Round flange at base CDH2...XC: MF4
(dimensions in mm)

ØAL	ØMM	KK	A	NV	ØD	ØDA	ØD4 ²⁾	EE ⁴⁾	EE ⁴⁾	Y	PJ	X1	WA
40 ⁶⁾	25/28	M20x1.5	28	19/22	88	52	34	G1/2	M22x1.5	83	120	41	18
50	32/36	M27x2	36	27/30	102	62	34	G1/2	M22x1.5	98	120	48.5	18
63	40/45	M33x2	45	32/36	120	78	42	G3/4	M27x2	112	133	56.5	21
80	50/56	M42x2	56	41/46	145	95	42	G3/4	M27x2	120	155	69.5	24
100	63/70	M48x2	63	50/60	170	125	47	G1	M33x2	134	171	82	27
125	80/90	M64x3	85	65/75	206	150	47	G1	M33x2	153	205	100.5	31
140	90/100	M72x3	90	75/85	226	170	58	G1 1/4	M42x2	166	219	109.5	31
160	100/110	M80x3	95	85/95	265	190	58	G1 1/4	M42x2	185	235	129.5	35
180	110/125	M90x3	105	95/110	292	210	58	G1 1/4	M42x2	194	264	143.5	40
200	125/140	M100x3	112	110/120	306	235	58	G1 1/4	M42x2	220	278	150.5	40
220 ⁶⁾	140/160	M125x4	125	120/140	355	270	65	G1 1/2	M48x2 ³⁾	244	326	174	42
250	160/180	M125x4	125	140/160	395	305	65	G1 1/2	M48x2 ³⁾	257	326	194	42
280 ⁶⁾	180/200	M160x4	160	160/180	445	343	65	G1 1/2	M48x2 ³⁾	290	375	220.5	48
320	200/220	M160x4	160	180/200	490	394	65	G1 1/2	M48x2 ³⁾	282	391	243	48

ØAL	ØMM	ZP	NF ^{js13}	VA	ØBA ^{H8}	ØFB ^{H13}	ØFC ^{js13}	ØUC ⁻¹	ØRA ⁷⁾	VE ⁷⁾	ØRA ⁸⁾	VE ⁸⁾
40 ⁶⁾	25/28	250	25	5	52	11	115	138	52	29	88	-
50	32/36	265	25	4	63	13.5	132	155	63	29	102	-
63	40/45	298	28	4	75	13.5	150	175	75	32	120	-
80	50/56	332	32	5	90	17.5	180	210	90	36	145	-
100	63/70	371	36	5	110	22	212	250	110	41	170	-
125	80/90	430	40	6	132	22	250	290	132	45	206	-
140	90/100	465	40	5	145	26	285	330	145	45	226	-
160	100/110	505	45	7	160	26	315	360	160	50	200	50
180	110/125	550	50	10	185	33	355	410	185	55	220	55
200	125/140	596	56	10	200	33	385	440	200	61	235	61
220 ⁶⁾	140/160	690	63	10	235	39	435	500	235	71	270	71
250	160/180	703	63	10	250	39	475	540	250	71	300	71
280 ⁶⁾	180/200	822	80	10	295	45	555	630	295	88	325	88
320	200/220	830	80	10	320	45	600	675	320	88	365	88

ØAL = Piston Ø

ØMM = Piston rod Ø

X* = Stroke length

¹⁾ Bleeding: With view to the piston rod, the position is offset by 90° in relation to the line connection (clockwise)

²⁾ Ø D4 max. 0.5 mm deep

³⁾ Thread size does not correspond to ISO 6022; M50 x 2 available upon request

⁴⁾ Flange connections see separate table pages 38 and 39

⁵⁾ Throttle valve only with end position cushioning "E" (180° for bleeding)

⁶⁾ Piston Ø not standardized

⁷⁾ Dimensions for cylinders with seal design M, T, and S

⁸⁾ Dimensions for cylinders with seal design A and B

¹⁶⁾ Equipotential bonding see pages 44 and 45

22/74 CDH2...XC / CGH2...XC / CSH2...XE | Hydraulic cylinders for explosive areas

Dimensions: Trunnion CDH2...XC / CGH2...XC: MT4

(dimensions in mm)

CDH2...XC: MT4

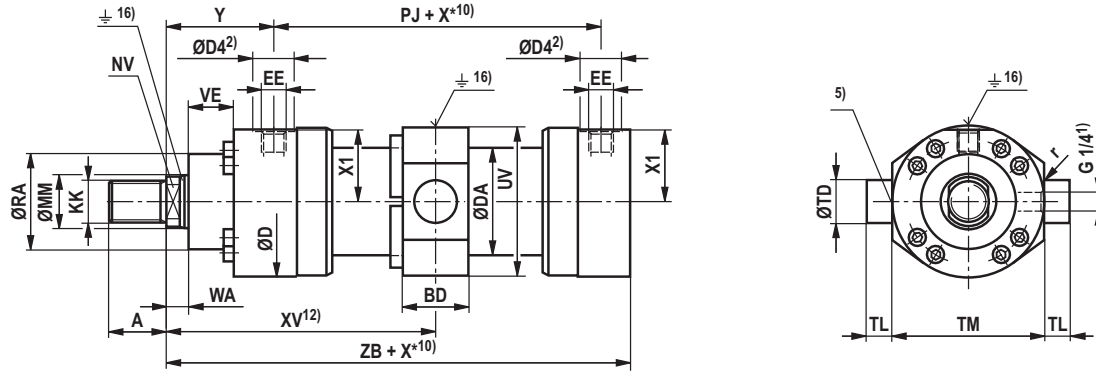

CDH2...XC: MT4: With seal design "A", "B" and AL Ø 160 ... 320 mm

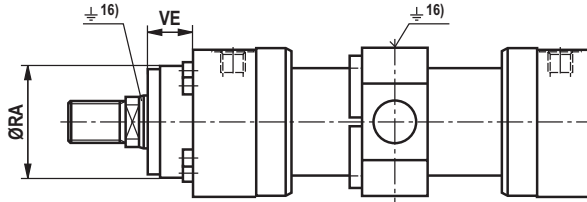

Dimensions for cylinder with piston rod extension "LY" in retracted condition

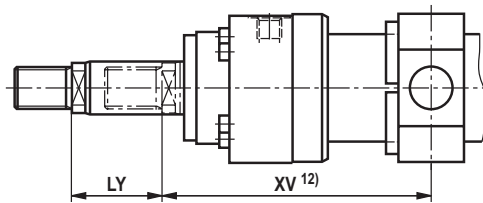

CGH2...XC: MT4 ¹¹⁾

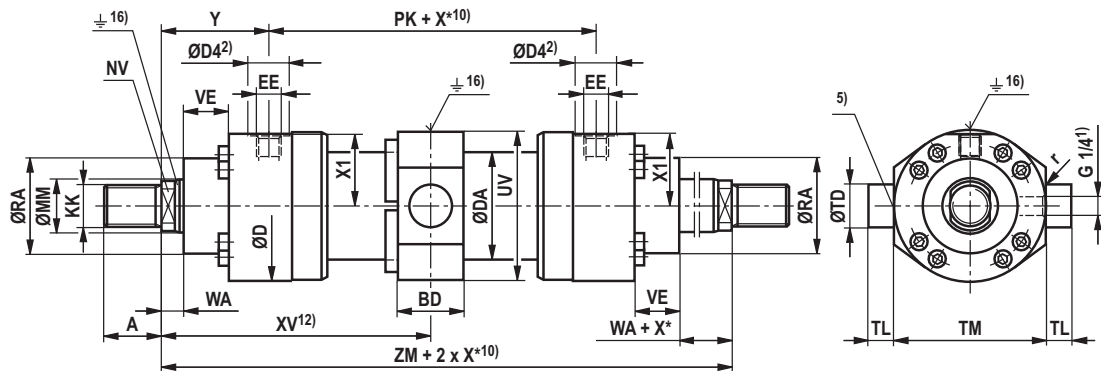

CGH2...XC: MT4 ¹¹⁾: With seal design "A", "B" and AL Ø 160 ... 320 mm

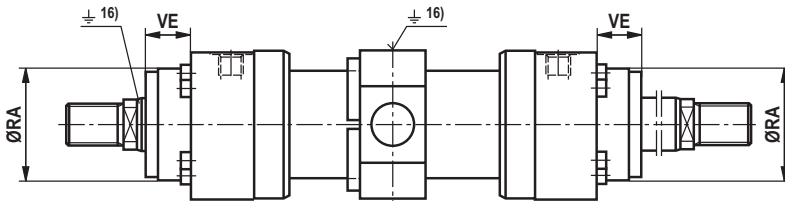

Bosch Rexroth AG, RE 17335, edition: 2014-03

Dimensions: Trunnion CDH2...XC / CGH2...XC: MT4
(dimensions in mm)

ØAL	ØMM	KK	A	NV	ØD	ØDA	ØD4 ²⁾	EE ⁴⁾	EE ⁴⁾	Y	PJ	X1	WA
40 ⁶⁾	25/28	M20x1.5	28	19/22	88	52	34	G1/2	M22x1.5	83	120	41	18
50	32/36	M27x2	36	27/30	102	62	34	G1/2	M22x1.5	98	120	48.5	18
63	40/45	M33x2	45	32/36	120	78	42	G3/4	M27x2	112	133	56.5	21
80	50/56	M42x2	56	41/46	145	95	42	G3/4	M27x2	120	155	69.5	24
100	63/70	M48x2	63	50/60	170	125	47	G1	M33x2	134	171	82	27
125	80/90	M64x3	85	65/75	206	150	47	G1	M33x2	153	205	100.5	31
140	90/100	M72x3	90	75/85	226	170	58	G1 1/4	M42x2	166	219	109.5	31
160	100/110	M80x3	95	85/95	265	190	58	G1 1/4	M42x2	185	235	129.5	35
180	110/125	M90x3	105	95/110	292	210	58	G1 1/4	M42x2	194	264	143.5	40
200	125/140	M100x3	112	110/120	306	235	58	G1 1/4	M42x2	220	278	150.5	40
220 ⁶⁾	140/160	M125x4	125	120/140	355	273	65	G1 1/2	M48x2 ³⁾	244	326	174	42
250	160/180	M125x4	125	140/160	395	305	65	G1 1/2	M48x2 ³⁾	257	326	194	42
280 ⁶⁾	180/200	M160x4	160	160/180	445	343	65	G1 1/2	M48x2 ³⁾	290	375	220.5	48
320	200/220	M160x4	160	180/200	490	394	65	G1 1/2	M48x2 ³⁾	282	391	243	48

ØAL	ØMM	PK	ZB max.	ZM	X* min.	XV ¹⁴⁾ cent.	XV ¹²⁾ min.	XV ¹²⁾ max.	BD	UV ¹⁵⁾	ØTD f8	TL js16	TM h12	r	ØRA ⁷⁾	VE ⁷⁾	ØRA ⁸⁾	VE ⁸⁾
40 ⁶⁾	25/28	120	230	286	22	143+X*/2	154	140+X*	38	97	25	20	95	0.8	52	29	88	-
50	32/36	120	244	316	32	158+X*/2	174	151+X*	38	111	32	25	112	0.8	63	29	102	-
63	40/45	133	274	357	47	178.5+X*/2	202	167+X*	48	129	40	32	125	1	75	32	120	-
80	50/56	155	305	395	58	197.5+X*/2	226.5	180.5+X*	58	163	50	40	150	1	90	36	145	-
100	63/70	171	340	439	79	219.5+X*/2	259	195+X*	78	188	63	50	180	1.2	110	41	170	-
125	80/90	205	396	511	91	255.5+X*/2	301	225+X*	98	234	80	63	224	1.2	132	45	206	-
140	90/100	219	430	551	121	275.5+X*/2	336	230+X*	118	257	90	70	265	1.5	145	45	226	-
160	100/110	235	467	605	142	302.5+X*/2	373.5	251.5+X*	128	287	100	80	280	1.5	160	50	200	50
180	110/125	264	510	652	158	326+X*/2	405	267+X*	138	328	110	90	320	1.5	185	55	220	55
200	125/140	278	550	718	204	359+X*/2	461	277+X*	178	343	125	100	335	1.5	200	61	235	61
220 ⁶⁾	140/160	326	637	814	200	407+X*/2	507	307+X*	180	393	160	125	385	1.5	235	71	270	71
250	160/180	326	650	840	210	420+X*/2	525	315+X*	180	433	160	125	425	1.5	250	71	300	71
280 ⁶⁾	180/200	375	752	955	241	477.5+X*/2	598	357+X*	220	486	200	160	480	2	295	88	325	88
320	200/220	391	760	955	245	477.5+X*/2	600	355+X*	220	536	200	160	530	2	320	88	365	88

ØAL = Piston Ø

ØMM = Piston rod Ø

X* = Stroke length

X*_{min.} = Min. stroke length

1) Bleeding: With view to the piston rod, the position is offset by 90° in relation to the line connection (clockwise)

2) Ø D4 max. 0.5 mm deep

3) Thread size does not correspond to ISO 6022; M50 x 2 available upon request

4) Flange connections see separate table pages 38 and 39

5) Throttle valve only with end position cushioning "E" (180° for bleeding)

6) Piston Ø not standardized

7) Dimensions for cylinders with seal design M, T, and S

8) Dimensions for cylinders with seal design A and B

10) Observe the min. stroke length "X*_{min.}"

11) Double-acting cylinder not standardized

12) When ordering, always specify the "XV" dimension in the plain text. Preferred XV dimension: Observe trunnion position in cylinder center XV_{min.} and XV_{max.}

14) XV_{cent.} recommendation: Trunnion position in cylinder center

15) The specified dimensions are maximum values, tolerance classes 342 according to ISO 9013 Thermal cutting

16) Equipotential bonding see pages 44 and 45

Important installation information!

During installation, it must be ensured that the trunnion bearings are installed up to the trunnion shoulders. Any non-compliance may reduce the product's service life.

Dimensions: Foot mounting CDH2...XC / CGH2...XC: MS2
(dimensions in mm)

ØAL	ØMM	KK	A	NV	ØD	ØDA	ØD4 ²⁾	EE ⁴⁾	EE ⁴⁾	Y	PJ	X1	WA
40 ⁶⁾	25/28	M20x1.5	28	19/22	88	52	34	G1/2	M22x1.5	83	120	41	18
50	32/36	M27x2	36	27/30	102	62	34	G1/2	M22x1.5	98	120	48.5	18
63	40/45	M33x2	45	32/36	120	78	42	G3/4	M27x2	112	133	56.5	21
80	50/56	M42x2	56	41/46	145	95	42	G3/4	M27x2	120	155	69.5	24
100	63/70	M48x2	63	50/60	170	125	47	G1	M33x2	134	171	82	27
125	80/90	M64x3	85	65/75	206	150	47	G1	M33x2	153	205	100.5	31
140	90/100	M72x3	90	75/85	226	170	58	G1 1/4	M42x2	166	219	109.5	31
160	100/110	M80x3	95	85/95	265	190	58	G1 1/4	M42x2	185	235	129.5	35
180	110/125	M90x3	105	95/110	292	210	58	G1 1/4	M42x2	194	264	143.5	40
200	125/140	M100x3	112	110/120	306	235	58	G1 1/4	M42x2	220	278	150.5	40
220 ⁶⁾	140/160	M125x4	125	120/140	355	270	65	G1 1/2	M48x2 ³⁾	244	326	174	42
250	160/180	M125x4	125	140/160	395	305	65	G1 1/2	M48x2 ³⁾	257	326	194	42
280 ⁶⁾	180/200	M160x4	160	160/180	445	343	65	G1 1/2	M48x2 ³⁾	290	375	220.5	48
320	200/220	M160x4	160	180/200	490	394	65	G1 1/2	M48x2 ³⁾	282	391	243	48

ØAL	ØMM	PK	XS	ZB max.	ZM	SS	X* ¹⁰⁾ min.	S	S1	ØSB H13	ST	TS js13	US ¹⁵⁾	LH	L1	ØRA ⁷⁾	VE ⁷⁾	ØRA ⁸⁾	VE ⁸⁾
40 ⁶⁾	25/28	120	118	230	286	50	1	30	15	11	32	110	140	45	93	52	29	88	-
50	32/36	120	135.5	244	316	45	1	35	17.5	11	37	130	161	55	110	63	29	102	-
63	40/45	133	154	274	357	49	1	40	20	13.5	42	150	183	65	129	75	32	120	-
80	50/56	155	171.5	305	395	52	2	50	25	17.5	47	180	220	75	149	90	36	145	-
100	63/70	171	189	340	439	61	3	60	30	22	57	210	260	90	181	110	41	170	-
125	80/90	205	218	396	511	75	1	70	35	26	67	255	313	105	215	132	45	206	-
140	90/100	219	240.5	430	551	70	19	85	42.5	30	72	290	359	115	235	145	45	226	-
160	100/110	235	270	467	605	65	44	105	52.5	33	77	330	402	135	277	160	50	200	50
180	110/125	264	291.5	510	652	69	50	115	57.5	40	92	360	445	150	305	185	55	220	55
200	125/140	278	322.5	550	718	73	56	125	62.5	40	97	385	471	160	322	200	61	235	61
220 ⁶⁾	140/160	326	369.5	637	814	75	100	155	77.5	45	102	445	541	185	373	235	71	270	71
250	160/180	326	382.5	650	840	75	100	155	77.5	52	112	500	610	205	414	250	71	300	71
280 ⁶⁾	180/200	375	415.5	752	955	124	51	155	77.5	52	142	550	661	235	469	295	88	325	88
320	200/220	391	435	760	955	85	125	190	95	62	142	610	732	255	512	320	88	365	88

ØAL = Piston Ø

ØMM = Piston rod Ø

X* = Stroke length

X*_{min.} = Min. stroke length

1) Bleeding: With view to the piston rod, the position is offset by 90° in relation to the line connection (clockwise)

2) Ø D4 max. 0.5 mm deep

3) Thread size does not correspond to ISO 6022; M50 x 2 available upon request

4) Flange connections see separate table pages 38 and 39

5) Throttle valve only with end position cushioning "E" (180° for bleeding)

6) Piston Ø not standardized

7) Dimensions for cylinders with seal design M, T, and S

8) Dimensions for cylinders with seal design A and B

10) Observe the min. stroke length "X*_{min.}"

11) Not standardized

12) Recess 2 mm deep, for hexagon socket head cap screws; ISO 4762 – The screws must not be subjected to shear force. Force introduction via additional external fitting strip

15) The specified dimensions are maximum values, tolerance classes 342 according to ISO 9013 Thermal cutting

16) Equipotential bonding see pages 44 and 45

Hydraulic cylinders for explosive areas | **CDH2...XC / CGH2...XC / CSH2...XE** 27/74

Dimensions: Swivel eye at base CSH2...XE: MP3
(dimensions in mm)

ØAL	ØMM	KK	A	NV	ØD	ØDA	ØD4 ²⁾	EE ⁴⁾	EE ⁴⁾	Y	PJ	X1	WA	XC	X* max.
40 ⁶⁾	25/28	M20x1.5	28	19/22	88	52	34	G1/2	M22x1.5	83	120	41	18	447	1000
50	32/36	M27x2	36	27/30	102	62	34	G1/2	M22x1.5	98	120	48.5	18	470	1000
63	40/45	M33x2	45	32/36	120	78	42	G3/4	M27x2	112	133	56.5	21	526	2000
80	50/56	M42x2	56	41/46	145	95	42	G3/4	M27x2	120	155	69.5	24	580	2000
100	63/70	M48x2	63	50/60	170	125	47	G1	M33x2	134	171	82	27	617	3000
125	80/90	M64x3	85	65/75	206	150	47	G1	M33x2	153	205	100.5	31	693	3000
140	90/100	M72x3	90	75/85	226	170	58	G1 1/4	M42x2	166	219	109.5	31	755	3000
160	100/110	M80x3	95	85/95	265	190	58	G1 1/4	M42x2	185	235	129.5	35	787	3000
180	110/125	M90x3	105	95/110	292	210	58	G1 1/4	M42x2	194	264	143.5	40	855	3000
200	125/140	M100x3	112	110/120	306	235	58	G1 1/4	M42x2	220	278	150.5	40	926	3000
220 ⁶⁾	140/160	M125x4	125	120/140	355	270	65	G1 1/2	M48x2 ³⁾	244	326	174	42	1100	3000
250	160/180	M125x4	125	140/160	395	305	65	G1 1/2	M48x2 ³⁾	257	326	194	42	1115	3000
280 ⁶⁾	180/200	M160x4	160	160/180	445	343	65	G1 1/2	M48x2 ³⁾	290	375	220.5	48	1295	3000
320	200/220	M160x4	160	180/200	490	394	65	G1 1/2	M48x2 ³⁾	282	391	243	48	1300	3000

ØAL	ØMM	L	L1	MR	M1	ØCD ^{H9}	EW ^{h12}	ØRA	VE	L2	H	L7	L8	B
40 ⁶⁾	25/28	53	8	32	32	25	25	52	29	124	115	200	101	64
50	32/36	61	8	40	40	32	32	63	29	132	120	200	109	64
63	40/45	74	8	50	50	40	40	75	32	150	130	200	127	64
80	50/56	90	10	63	63	50	50	90	36	176.5	125	200	149	64
100	63/70	102	12	71	71	63	63	110	41	192	135	200	164	64
125	80/90	124	16	90	90	80	80	132	45	227	145	200	203	64
140	90/100	149	16	100	100	90	90	145	45	262	155	200	236	64
160	100/110	150	16	112	112	100	100	160	50	269.5	165	200	237	64
180	110/125	180	20	129	129	110	110	185	55	307	175	200	274	64
200	125/140	206	20	145	145	125	125	200	61	333	190	200	302	64
220 ⁶⁾	140/160	253	20	179 ¹²⁾	187 ¹²⁾	160	160	235	71	418	205	200	386	64
250	160/180	253	24	179 ¹²⁾	187 ¹²⁾	160	160	250	71	420	220	200	387	64
280 ⁶⁾	180/200	320	30	230 ¹²⁾	240 ¹²⁾	200	200	295	88	510	280	200	475	64
320	200/220	320	30	231 ¹²⁾	241 ¹²⁾	200	200	320	88	520	300	200	485	64

ØAL = Piston Ø

ØMM = Piston rod Ø

X* = Stroke length

X*_{max.} = Max. stroke length

1) Bleeding: With view to the piston rod, the position is offset by 90° in relation to the line connection (clockwise)

2) Ø D4 max. 0.5 mm deep

3) Thread size does not correspond to ISO 6022; M50 x 2 available upon request

4) Flange connections see separate table pages 38 and 39

5) Throttle valve only with end position cushioning "E" (180° for bleeding)

6) Piston Ø not standardized

10) Standard version "W" Lubricating nipple, cone head form A according to DIN 71412

11) Related bolt Ø f8

12) The specified dimensions are maximum values, tolerance classes 342 according to ISO 9013 Thermal cutting

16) Equipotential bonding see pages 44 and 45

RE 17335-X, edition: 2014-03, **Bosch Rexroth AG**

Hydraulic cylinders for explosive areas | **CDH2...XC / CGH2...XC / CSH2...XE** 29/74

Dimensions: Self-aligning clevis at base CSH2...XE: MP5
(dimensions in mm)

ØAL	ØMM	KK	A	NV	ØD	ØDA	ØD4 ²⁾	EE ⁴⁾	EE ⁴⁾	Y	PJ	X1	WA	XO	X* max.
40 ⁶⁾	25/28	M20x1.5	28	19/22	88	52	34	G1/2	M22x1.5	83	120	41	18	447	1000
50	32/36	M27x2	36	27/30	102	62	34	G1/2	M22x1.5	98	120	48.5	18	470	1000
63	40/45	M33x2	45	32/36	120	78	42	G3/4	M27x2	112	133	56.5	21	526	2000
80	50/56	M42x2	56	41/46	145	95	42	G3/4	M27x2	120	155	69.5	24	580	2000
100	63/70	M48x2	63	50/60	170	125	47	G1	M33x2	134	171	82	27	617	3000
125	80/90	M64x3	85	65/75	206	150	47	G1	M33x2	153	205	100.5	31	693	3000
140	90/100	M72x3	90	75/85	226	170	58	G1 1/4	M42x2	166	219	109.5	31	755	3000
160	100/110	M80x3	95	85/95	265	190	58	G1 1/4	M42x2	185	235	129.5	35	787	3000
180	110/125	M90x3	105	95/110	292	210	58	G1 1/4	M42x2	194	264	143.5	40	855	3000
200	125/140	M100x3	112	110/120	306	235	58	G1 1/4	M42x2	220	278	150.5	40	926	3000
220 ⁶⁾	140/160	M125x4	125	120/140	355	270	65	G1 1/2	M48x2 ³⁾	244	326	174	42	1100	3000
250	160/180	M125x4	125	140/160	395	305	65	G1 1/2	M48x2 ³⁾	257	326	194	42	1115	3000
280 ⁶⁾	180/200	M160x4	160	160/180	445	343	65	G1 1/2	M48x2 ³⁾	290	375	220.5	48	1295	3000
320	200/220	M160x4	160	180/200	490	394	65	G1 1/2	M48x2 ³⁾	282	391	243	48	1300	3000

ØAL	ØMM	LT	L1	MS	M1	ØCX ¹¹⁾ H7	EP	EX ^{h12}	ØRA	VE	Z	L2	H	L7	L8	B
40 ⁶⁾	25/28	53	8	32	32	25	22	25	52	29	2°	124	115	200	101	64
50	32/36	61	8	40	40	32	27	32	63	29	4°	132	120	200	109	64
63	40/45	74	8	50	50	40	32	40	75	32	4°	150	130	200	127	64
80	50/56	90	10	63	63	50	40	50	90	36	4°	176.5	125	200	149	64
100	63/70	102	12	71	71	63	52	63	110	41	4°	192	135	200	164	64
125	80/90	124	16	90	90	80	66	80	132	45	4°	227	145	200	203	64
140	90/100	149	16	100	100	90	72	90	145	45	4°	262	155	200	236	64
160	100/110	150	16	112	112	100	84	100	160	50	4°	269.5	165	200	237	64
180	110/125	180	20	129	129	110	88	110	185	55	4°	307	175	200	274	64
200	125/140	206	20	145	145	125	102	125	200	61	4°	333	190	200	302	64
220 ⁶⁾	140/160	253	20	179 ¹²⁾	187 ¹²⁾	160	130	160	235	71	4°	418	205	200	386	64
250	160/180	253	24	179 ¹²⁾	187 ¹²⁾	160	130	160	250	71	4°	420	220	200	387	64
280 ⁶⁾	180/200	320	30	230 ¹²⁾	240 ¹²⁾	200	138	200	295	88	4°	510	280	200	475	64
320	200/220	320	30	231 ¹²⁾	241 ¹²⁾	200	162	200	320	88	4°	520	300	200	485	64

ØAL = Piston Ø

ØMM = Piston rod Ø

X* = Stroke length

X*_{max.} = Max. stroke length

1) Bleeding: With view to the piston rod, the position is offset by 90° in relation to the line connection (clockwise)

2) Ø D4 max. 0.5 mm deep

3) Thread size does not correspond to ISO 6022; M50 x 2 available upon request

4) Flange connections see separate table pages 38 and 39

5) Throttle valve only with end position cushioning "E" (180° for bleeding)

6) Piston Ø not standardized

10) Standard version "W" Lubricating nipple, cone head form A according to DIN 71412

11) Related bolt Ø m6

12) The specified dimensions are maximum values, tolerance classes 342 according to ISO 9013 Thermal cutting

16) Equipotential bonding see pages 44 and 45

RE 17335-X, edition: 2014-03, **Bosch Rexroth AG**

30/74 CDH2...XC / CGH2...XC / CSH2...XE | Hydraulic cylinders for explosive areas

Dimensions: Round flange at head CSH2...XE: MF3
(dimensions in mm)

CSH2...XE: MF3

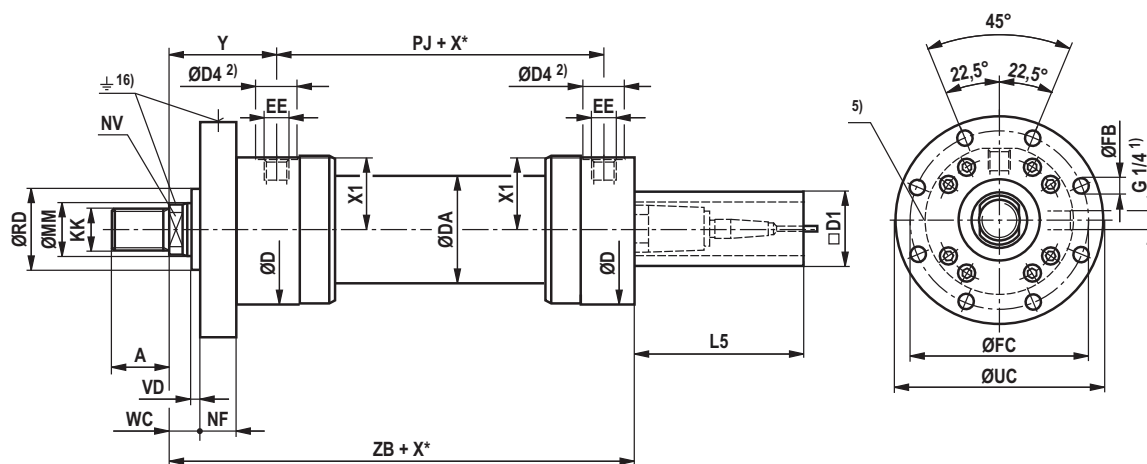

Bosch Rexroth AG, RE 17335, edition: 2014-03

Hydraulic cylinders for explosive areas | **CDH2...XC / CGH2...XC / CSH2...XE** 31/74

Dimensions: Round flange at head CSH2...XE: MF3

(dimensions in mm)

ØAL	ØMM	KK	A	NV	ØD	ØDA	ØD4 ²⁾	EE ⁴⁾	EE ⁴⁾	Y	PJ	X1	X* max.	L5	D1 max.
40 ⁶⁾	25/28	M20x1.5	28	19/22	88	52	34	G1/2	M22x1.5	83	120	41	1000	166	80
50	32/36	M27x2	36	27/30	102	62	34	G1/2	M22x1.5	98	120	48.5	1000	166	96
63	40/45	M33x2	45	32/36	120	78	42	G3/4	M27x2	112	133	56.5	2000	166	96
80	50/56	M42x2	56	41/46	145	95	42	G3/4	M27x2	120	155	69.5	2000	166	96
100	63/70	M48x2	63	50/60	170	125	47	G1	M33x2	134	171	82	3000	166	96
125	80/90	M64x3	85	65/75	206	150	47	G1	M33x2	153	205	100.5	3000	166	96
140	90/100	M72x3	90	75/85	226	170	58	G1 1/4	M42x2	166	219	109.5	3000	166	96
160	100/110	M80x3	95	85/95	265	190	58	G1 1/4	M42x2	185	235	129.5	3000	166	96
180	110/125	M90x3	105	95/110	292	210	58	G1 1/4	M42x2	194	264	143.5	3000	166	96
200	125/140	M100x3	112	110/120	306	235	58	G1 1/4	M42x2	220	278	150.5	3000	166	96
220 ⁶⁾	140/160	M125x4	125	120/140	355	270	65	G1 1/2	M48x2 ³⁾	244	326	174	3000	166	96
250	160/180	M125x4	125	140/160	395	305	65	G1 1/2	M48x2 ³⁾	257	326	194	3000	166	96
280 ⁶⁾	180/200	M160x4	160	160/180	445	343	65	G1 1/2	M48x2 ³⁾	290	375	220.5	3000	166	96
320	200/220	M160x4	160	180/200	490	394	65	G1 1/2	M48x2 ³⁾	282	391	243	3000	166	96

ØAL	ØMM	ØRD f8	WC	VD	NF js13	ZB max.	ØFB H13	ØFC js13	ØUC -1
40 ⁶⁾	25/28	52	22	4	25	239	11	115	138
50	32/36	63	22	4	25	254	13.5	132	155
63	40/45	75	25	4	28	299	13.5	150	175
80	50/56	90	28	4	32	332.5	17.5	180	210
100	63/70	110	32	5	36	362	22	212	250
125	80/90	132	36	5	40	410	22	250	290
140	90/100	145	36	5	40	440	26	285	330
160	100/110	160	40	5	45	472.5	26	315	360
180	110/125	185	45	5	50	510	33	355	410
200	125/140	200	45	5	56	550	33	385	440
220 ⁶⁾	140/160	235	50	8	63	637	39	435	500
250	160/180	250	50	8	63	650	39	475	540
280 ⁶⁾	180/200	295	56	8	80	752	45	555	630
320	200/220	320	56	8	80	760	45	600	675

ØAL = Piston Ø

ØMM = Piston rod Ø

X* = Stroke length

X*_{max.} = Max. stroke length

¹⁾ Bleeding: With view to the piston rod, the position is offset by 90° in relation to the line connection (clockwise)

²⁾ Ø D4 max. 0.5 mm deep

³⁾ Thread size does not correspond to ISO 6022; M50 x 2 available upon request

⁴⁾ Flange connections see separate table pages 38 and 39

⁵⁾ Throttle valve only with end position cushioning "E" (180° for bleeding)

⁶⁾ Piston Ø not standardized

¹⁶⁾ Equipotential bonding see pages 44 and 45

RE 17335-X, edition: 2014-03, **Bosch Rexroth AG**

Dimensions: Round flange at base CSH2...XE: MF4
(dimensions in mm)

ØAL	ØMM	KK	A	NV	ØD	ØDA	ØD4 ²⁾	EE ⁴⁾	EE ⁴⁾	Y	PJ	X1	WA	X* max.	L4
40 ⁶⁾	25/28	M20x1.5	28	19/22	88	52	34	G1/2	M22x1.5	83	120	41	18	1000	3
50	32/36	M27x2	36	27/30	102	62	34	G1/2	M22x1.5	98	120	48.5	18	1000	3
63	40/45	M33x2	45	32/36	120	78	42	G3/4	M27x2	112	133	56.5	21	2000	0
80	50/56	M42x2	56	41/46	145	95	42	G3/4	M27x2	120	155	69.5	24	2000	0
100	63/70	M48x2	63	50/60	170	125	47	G1	M33x2	134	171	82	27	3000	0
125	80/90	M64x3	85	65/75	206	150	47	G1	M33x2	153	205	100.5	31	3000	21.5
140	90/100	M72x3	90	75/85	226	170	58	G1 1/4	M42x2	166	219	109.5	31	3000	25.5
160	100/110	M80x3	95	85/95	265	190	58	G1 1/4	M42x2	185	235	129.5	35	3000	25.5
180	110/125	M90x3	105	95/110	292	210	58	G1 1/4	M42x2	194	264	143.5	40	3000	32
200	125/140	M100x3	112	110/120	306	235	58	G1 1/4	M42x2	220	278	150.5	40	3000	32
220 ⁶⁾	140/160	M125x4	125	120/140	355	270	65	G1 1/2	M48x2 ³⁾	244	326	174	42	3000	38
250	160/180	M125x4	125	140/160	395	305	65	G1 1/2	M48x2 ³⁾	257	326	194	42	3000	38
280 ⁶⁾	180/200	M160x4	160	160/180	445	343	65	G1 1/2	M48x2 ³⁾	290	375	220.5	48	3000	44
320	200/220	M160x4	160	180/200	490	394	65	G1 1/2	M48x2 ³⁾	282	391	243	48	3000	44

ØAL	ØMM	L6	ØD2	D1 max.	ZP	NX js13	ØFB H13	ØFC js13	ØUC -1	ØRA	VE
40 ⁶⁾	25/28	166	18	80	262	28	11	115	138	52	29
50	32/36	166	20	96	278	28	13.5	132	155	63	29
63	40/45	166	0	96	313	28	13.5	150	175	75	32
80	50/56	166	0	96	350	32	17.5	180	210	90	36
100	63/70	138	0	96	390	36	22	212	250	110	41
125	80/90	131	33	96	445	55	22	250	290	132	45
140	90/100	121	40	96	485	60	26	285	330	145	45
160	100/110	113.5	40	96	525	65	26	315	360	160	50
180	110/125	106	48	96	570	70	33	355	410	185	55
200	125/140	100	48	96	616	76	33	385	440	200	61
220 ⁶⁾	140/160	88	57	96	715	88	39	435	500	235	71
250	160/180	86	57	96	730	90	39	475	540	250	71
280 ⁶⁾	180/200	61	66	96	857	115	45	555	630	295	88
320	200/220	61	66	96	865	115	45	600	675	320	88

ØAL = Piston Ø

ØMM = Piston rod Ø

X* = Stroke length

X*_{max.} = Max. stroke length

¹⁾ Bleeding: With view to the piston rod, the position is offset by 90° in relation to the line connection (clockwise)

²⁾ Ø D4 max. 0.5 mm deep

³⁾ Thread size does not correspond to ISO 6022; M50 x 2 available upon request

⁴⁾ Flange connections see separate table pages 38 and 39

⁵⁾ Throttle valve only with end position cushioning "E" (180° for bleeding)

⁶⁾ Piston Ø not standardized

¹⁶⁾ Equipotential bonding see pages 44 and 45

Hydraulic cylinders for explosive areas | **CDH2...XC / CGH2...XC / CSH2...XE** 35/74

Dimensions: Trunnion CSH2...XE: MT4 (dimensions in mm)

ØAL	ØMM	KK	A	NV	ØD	ØDA	ØD4 ²⁾	EE ⁴⁾	EE ⁴⁾	Y	PJ	X1	WA	X* max.	L5	D1 max.
40 ⁶⁾	25/28	M20x1.5	28	19/22	88	52	34	G1/2	M22x1.5	83	120	41	18	1000	166	80
50	32/36	M27x2	36	27/30	102	62	34	G1/2	M22x1.5	98	120	48.5	18	1000	166	96
63	40/45	M33x2	45	32/36	120	78	42	G3/4	M27x2	112	133	56.5	21	2000	166	96
80	50/56	M42x2	56	41/46	145	95	42	G3/4	M27x2	120	155	69.5	24	2000	166	96
100	63/70	M48x2	63	50/60	170	125	47	G1	M33x2	134	171	82	27	3000	166	96
125	80/90	M64x3	85	65/75	206	150	47	G1	M33x2	153	205	100.5	31	3000	166	96
140	90/100	M72x3	90	75/85	226	170	58	G1 1/4	M42x2	166	219	109.5	31	3000	166	96
160	100/110	M80x3	95	85/95	265	190	58	G1 1/4	M42x2	185	235	129.5	35	3000	166	96
180	110/125	M90x3	105	95/110	292	210	58	G1 1/4	M42x2	194	264	143.5	40	3000	166	96
200	125/140	M100x3	112	110/120	306	235	58	G1 1/4	M42x2	220	278	150.5	40	3000	166	96
220 ⁶⁾	140/160	M125x4	125	120/140	355	273	65	G1 1/2	M48x2 ³⁾	244	326	174	42	3000	166	96
250	160/180	M125x4	125	140/160	395	305	65	G1 1/2	M48x2 ³⁾	257	326	194	42	3000	166	96
280 ⁶⁾	180/200	M160x4	160	160/180	445	343	65	G1 1/2	M48x2 ³⁾	290	375	220.5	48	3000	166	96
320	200/220	M160x4	160	180/200	490	394	65	G1 1/2	M48x2 ³⁾	282	391	243	48	3000	166	96

ØAL	ØMM	ZB max.	X* min.	XV ¹⁴⁾ cent.	XV ¹²⁾ min.	XV ¹²⁾ max.	BD	UV ¹⁵⁾	ØTD f8	TL js16	TM h12	r	ØRA	VE
40 ⁶⁾	25/28	239	22	143+X*/2	154	140+X*	38	97	25	20	95	0.8	52	29
50	32/36	254	32	158+X*/2	174	151+X*	38	111	32	25	112	0.8	63	29
63	40/45	299	47	178.5+X*/2	202	167+X*	48	129	40	32	125	1	75	32
80	50/56	332.5	58	197.5+X*/2	226.5	180.5+X*	58	163	50	40	150	1	90	36
100	63/70	362	79	219.5+X*/2	259	195+X*	78	188	63	50	180	1.2	110	41
125	80/90	410	91	255.5+X*/2	301	225+X*	98	234	80	63	224	1.2	132	45
140	90/100	440	121	275.5+X*/2	336	230+X*	118	257	90	70	265	1.5	145	45
160	100/110	472.5	142	302.5+X*/2	373.5	251.5+X*	128	287	100	80	280	1.5	160	50
180	110/125	510	158	326+X*/2	405	267+X*	138	328	110	90	320	1.5	185	55
200	125/140	550	204	359+X*/2	461	277+X*	178	343	125	100	335	1.5	200	61
220 ⁶⁾	140/160	637	200	407+X*/2	507	307+X*	180	393	160	125	385	1.5	235	71
250	160/180	650	210	420+X*/2	525	315+X*	180	433	160	125	425	1.5	250	71
280 ⁶⁾	180/200	752	241	477.5+X*/2	598	357+X*	220	486	200	160	480	2	295	88
320	200/220	760	245	477.5+X*/2	600	355+X*	220	536	200	160	530	2	320	88

ØAL = Piston Ø

ØMM = Piston rod Ø

X* = Stroke length

X*_{max.} = Max. stroke length

X*_{min.} = Min. stroke length

¹⁾ Bleeding: With view to the piston rod, the position is offset by 90° in relation to the line connection (clockwise)

²⁾ Ø D4 max. 0.5 mm deep

³⁾ Thread size does not correspond to ISO 6022; M50 x 2 available upon request

⁴⁾ Flange connections see separate table pages 38 and 39

⁵⁾ Throttle valve only with end position cushioning "E" (180° for bleeding)

⁶⁾ Piston Ø not standardized

¹⁰⁾ Observe the min. stroke length "X*_{min.}"

¹¹⁾ Double-acting cylinder not standardized

¹²⁾ When ordering, always specify the "XV" dimension in the plain text. Preferred XV dimension: Observe trunnion position in cylinder center XV_{min.} and XV_{max.}

¹⁴⁾ XV_{cent.} recommendation: Trunnion position in cylinder center

¹⁵⁾ The specified dimensions are maximum values, tolerance classes 342 according to ISO 9013 Thermal cutting

¹⁶⁾ Equipotential bonding see pages 44 and 45

Important installation information!

During installation, it must be ensured that the trunnion bearings are installed up to the trunnion shoulders. Any non-compliance may reduce the product's service life.

RE 17335-X, edition: 2014-03, **Bosch Rexroth AG**

36/74 CDH2...XC / CGH2...XC / CSH2...XE | Hydraulic cylinders for explosive areas

Dimensions: Foot mounting CSH2...XE: MS2

(dimensions in mm)

CSH2...XE MS2

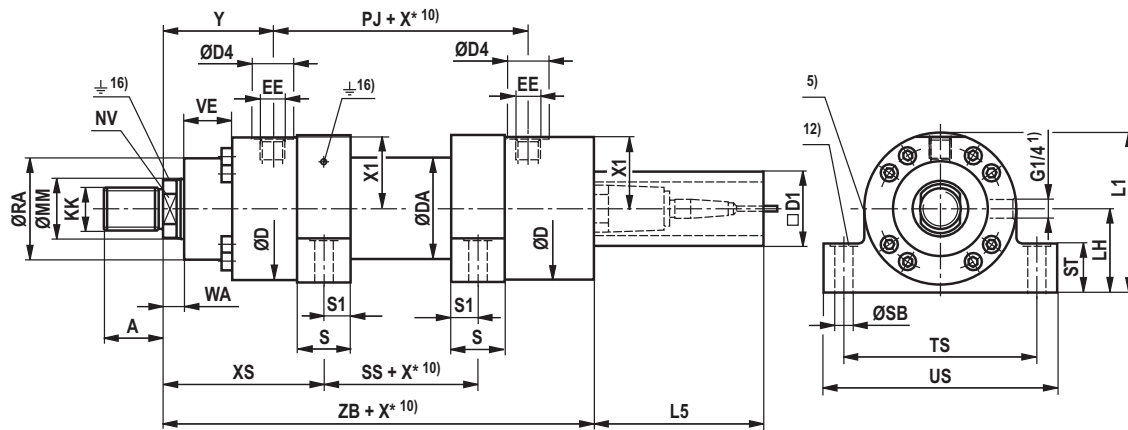

Bosch Rexroth AG, RE 17335, edition: 2014-03

Hydraulic cylinders for explosive areas | **CDH2...XC / CGH2...XC / CSH2...XE** 37/74

Dimensions: Foot mounting CSH2...XE: MS2 (dimensions in mm)

ØAL	ØMM	KK	A	NV	ØD	ØDA	ØD4 ²⁾	EE ⁴⁾	EE ⁴⁾	Y	PJ	X1	WA	X* max.
40 ⁶⁾	25/28	M20x1.5	28	19/22	88	52	34	G1/2	M22x1.5	83	120	41	18	1000
50	32/36	M27x2	36	27/30	102	62	34	G1/2	M22x1.5	98	120	48.5	18	1000
63	40/45	M33x2	45	32/36	120	78	42	G3/4	M27x2	112	133	56.5	21	2000
80	50/56	M42x2	56	41/46	145	95	42	G3/4	M27x2	120	155	69.5	24	2000
100	63/70	M48x2	63	50/60	170	125	47	G1	M33x2	134	171	82	27	3000
125	80/90	M64x3	85	65/75	206	150	47	G1	M33x2	153	205	100.5	31	3000
140	90/100	M72x3	90	75/85	226	170	58	G1 1/4	M42x2	166	219	109.5	31	3000
160	100/110	M80x3	95	85/95	265	190	58	G1 1/4	M42x2	185	235	129.5	35	3000
180	110/125	M90x3	105	95/110	292	210	58	G1 1/4	M42x2	194	264	143.5	40	3000
200	125/140	M100x3	112	110/120	306	235	58	G1 1/4	M42x2	220	278	150.5	40	3000
220 ⁶⁾	140/160	M125x4	125	120/140	355	270	65	G1 1/2	M48x2 ³⁾	244	326	174	42	3000
250	160/180	M125x4	125	140/160	395	305	65	G1 1/2	M48x2 ³⁾	257	326	194	42	3000
280 ⁶⁾	180/200	M160x4	160	160/180	445	343	65	G1 1/2	M48x2 ³⁾	290	375	220.5	48	3000
320	200/220	M160x4	160	180/200	490	394	65	G1 1/2	M48x2 ³⁾	282	391	243	48	3000

ØAL	ØMM	L5	D1 max.	XS	ZB max.	SS	X* ¹⁰⁾ min.	S	S1	ØSB H13	ST	TS js13	US ¹⁵⁾	LH	L1 ¹⁵⁾	ØRA	VE
40 ⁶⁾	25/28	166	80	118	239	50	1	30	15	11	32	110	140	45	93	52	29
50	32/36	166	96	135.5	254	45	1	35	17.5	11	37	130	161	55	110	63	29
63	40/45	166	96	154	299	49	1	40	20	13.5	42	150	183	65	129	75	32
80	50/56	166	96	171.5	332.5	52	2	50	25	17.5	47	180	220	75	149	90	36
100	63/70	166	96	189	362	61	3	60	30	22	57	210	260	90	181	110	41
125	80/90	166	96	218	410	75	1	70	35	26	67	255	313	105	215	132	45
140	90/100	166	96	240.5	440	70	19	85	42.5	30	72	290	359	115	235	145	45
160	100/110	166	96	270	472.5	65	44	105	52.5	33	77	330	402	135	277	160	50
180	110/125	166	96	291.5	510	69	50	115	57.5	40	92	360	445	150	305	185	55
200	125/140	166	96	322.5	550	73	56	125	62.5	40	97	385	471	160	322	200	61
220 ⁶⁾	140/160	166	96	369.5	637	75	100	155	77.5	45	102	445	541	185	373	235	71
250	160/180	166	96	382.5	650	75	100	155	77.5	52	112	500	610	205	414	250	71
280 ⁶⁾	180/200	166	96	415.5	752	124	51	155	77.5	52	142	550	661	235	469	295	88
320	200/220	166	96	435	760	85	125	190	95	62	142	610	732	255	512	320	88

ØAL = Piston Ø

ØMM = Piston rod Ø

X* = Stroke length

X*_{max.} = Max. stroke length

X*_{min.} = Min. stroke length

1) Bleeding: With view to the piston rod, the position is offset by 90° in relation to the line connection (clockwise)

2) Ø D4 max. 0.5 mm deep

3) Thread size does not correspond to ISO 6022; M50 x 2 available upon request

4) Flange connections see separate table pages 38 and 39

5) Throttle valve only with end position cushioning "E" (180° for bleeding)

6) Piston Ø not standardized

10) Observe the min. stroke length "X*_{min.}"

12) Recess 2 mm deep, for hexagon socket head cap screws; ISO 4762 – The screws must not be subjected to shear force. Force introduction via additional external fitting strip

15) The specified dimensions are maximum values, tolerance classes 342 according to ISO 9013 Thermal cutting

16) Equipotential bonding see pages 44 and 45

RE 17335-X, edition: 2014-03, **Bosch Rexroth AG**

38/74 CDH2...XC / CGH2...XC / CSH2...XE | Hydraulic cylinders for explosive areas

Dimensions: Flange ports

(dimensions in mm)

CDH2...XC / CSH2...XE

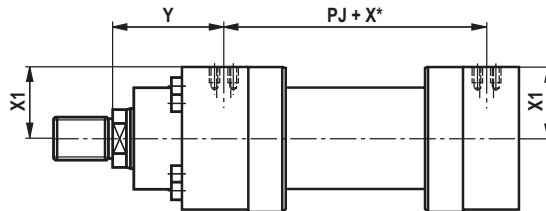

CGH2...XC

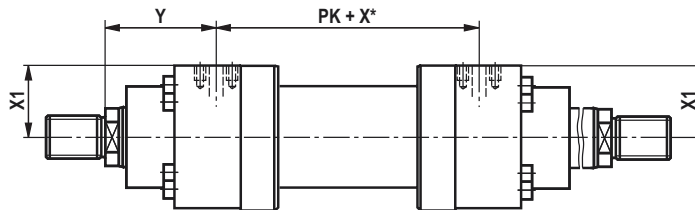

Porting pattern for rectangular flange according to ISO 6162-1 tab. 2 type 1 and ISO 6162-2 tab. 2 type 1

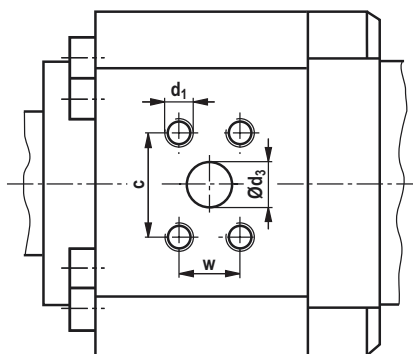

Porting pattern for square flange according to ISO 6164 table 1 and ISO 6164 table 2

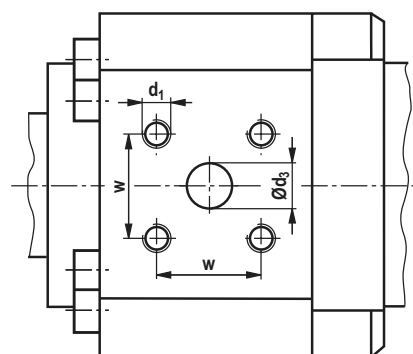

Bosch Rexroth AG, RE 17335, edition: 2014-03

Hydraulic cylinders for explosive areas | **CDH2...XC / CGH2...XC / CSH2...XE** 39/74

Dimensions: Flange ports (dimensions in mm)

ØAL	Version "F" ⁶⁾ ISO 6162-1 tab. 2 type 1 (200 ... 350 bar) (½ SAE 3000 PSI)											Version "K" ⁷⁾ ISO 6164 tab. 1 (250 bar)								
	Y	PJ PK	X1	Ød ₃	Ød ₃ ⁴⁾	c ±0.25	w ±0.25	d ₁	t ₁ ¹⁾	t ₁ ²⁾	p ³⁾	Y	PJ PK	X1	Ød ₃	w ±0.25	d ₁	t ₁ ¹⁾	t ₁ ²⁾	p ³⁾
40	-	-	-	-	-	-	-	-	-	-	-	82	122	40.5	10	24.7	M6	12.5	10	250
50	-	-	-	-	-	-	-	-	-	-	-	97	122	48	10	24.7	M6	12.5	12.5	250
63	111	135	55	13	1/2"	38.1	17.5	M8	16	16	350	111	135	57	13	29.7	M8	16	16	250
80	123.5	148	68	13	1/2"	38.1	17.5	M8	16	16	350	123.5	148	69.5	13	29.7	M8	16	16	250
100	133	173	79	19	3/4"	47.6	22.3	M10	20	20	350	133	173	81.5	19	35.4	M8	16	16	250
125	153	205	98	25	1"	52.4	26.2	M10	20	20	350	157	197	100	19	35.4	M8	16	16	250
140	162	227	107	32	1 1/4"	58.7	30.2	M10	20	20	250	162	227	109	25	43.8	M10	20	20	250
160	181.5	242	127	32	1 1/4"	58.7	30.2	M10	20	20	250	181.5	242	128.5	25	43.8	M10	20	20	250
180	193	266	139	38	1 1/2"	69.9	35.7	M12	24	24	200	194	264	142	32	51.6	M12	24	24	250
200	219	280	146.5	38	1 1/2"	69.9	35.7	M12	24	24	200	220	278	148.5	32	51.6	M12	24	24	250

ØAL	Version "D" ⁸⁾ ISO 6162-2 tab. 2 type 1 (400 bar) (½ SAE 6000 PSI)											Version "H" ⁸⁾ ISO 6164 tab. 2 (400 bar)								
	Y	PJ PK	X1	Ød ₃	Ød ₃ ⁵⁾	c ±0.25	w ±0.25	d ₁	t ₁ ¹⁾	t ₁ ²⁾	p ³⁾	Y	PJ PK	X1	Ød ₃	w ±0.25	d ₁	t ₁ ¹⁾	t ₁ ²⁾	p ³⁾
40	-	-	-	-	-	-	-	-	-	-	-	82	122	40.5	10	24.7	M6	12.5	10	400
50	-	-	-	-	-	-	-	-	-	-	-	97	122	48	10	24.7	M6	12.5	12.5	400
63	-	-	-	-	-	-	-	-	-	-	-	111	135	57	13	29.7	M8	16	16	400
80	120	155	67	13	1/2"	40.5	18.2	M8	16	14	400	123.5	148	69.5	13	29.7	M8	16	16	400
100	134	171	80.5	13	1/2"	40.5	18.2	M8	16	16	400	133	173	81.5	19	35.4	M8	16	16	400
125	153	205	97	19	3/4"	50.8	23.8	M10	20	20	400	157	197	100	19	35.4	M8	16	16	400
140	162	227	107	25	1"	57.2	27.8	M12	24	24	400	162	227	109	25	43.8	M10	20	20	400
160	181.5	242	127	25	1"	57.2	27.8	M12	24	24	400	181.5	242	128.5	25	43.8	M10	20	20	400
180	194	264	139.5	32	1 1/4"	66.6	31.8	M14	26	26	400	194	264	142	32	51.6	M12	24	24	400
200	220	278	147	32	1 1/4"	66.6	31.8	M14	26	26	400	220	278	148.5	32	51.6	M12	24	24	400
220	244	326	168	38	1 1/2"	79.3	36.5	M16	30	30	400	244	326	171	38	60.1	M16	30	30	400
250	257	326	189	38	1 1/2"	79.3	36.5	M16	30	30	400	257	326	192	38	60.1	M16	30	30	400
280	290	375	215	38	1 1/2"	79.3	36.5	M16	30	30	400	290	375	218	38	60.1	M16	30	30	400
320	282	391	236	51	2"	96.8	44.5	M20	36	36	400	282	391	240	51	69.3	M16	30	30	400

Main dimensions see pages 14 to 37

ØAL = Piston Ø

X* = Stroke length

¹⁾ Thread depth for seal design M, T, and S

²⁾ Thread depth for seal design A and B

³⁾ Max. operating pressure for related flanges in bar

⁴⁾ Flange porting pattern according to ISO 6162-1 tab. 2 type 1 corresponds to flange porting pattern according to SAE 3000 PSI

⁵⁾ Flange porting pattern according to ISO 6162-2 tab. 2 type 1 corresponds to flange porting pattern according to SAE 6000 PSI

⁶⁾ Version "F" with piston Ø 125 ... 200 mm not standardized

⁷⁾ Version "K" with piston Ø 40 ... 50 mm and piston Ø 180 ... 200 mm not standardized

⁸⁾ Versions "D" and "H" not standardized

RE 17335-X, edition: 2014-03, **Bosch Rexroth AG**

40/74 CDH2...XC / CGH2...XC / CSH2...XE | Hydraulic cylinders for explosive areas

Dimensions: Bleeding/measuring coupling (dimensions in mm)

By default, a patented safety bleeding device against unintended screwing out in head and base is delivered for all cylinders.

The port allows for the installation of a measuring coupling with check valve for pressure measurement or contamination-free bleeding. Measuring coupling with check valve function, i.e. it can also be connected when the system is pressurized.

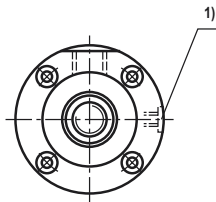

1) Bleeding: With view to the piston rod, the position is offset by 90° in relation to the line connection (clockwise)

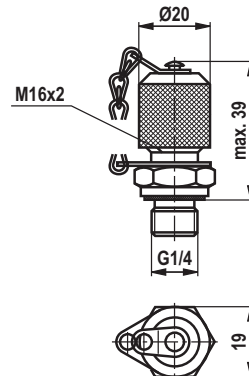
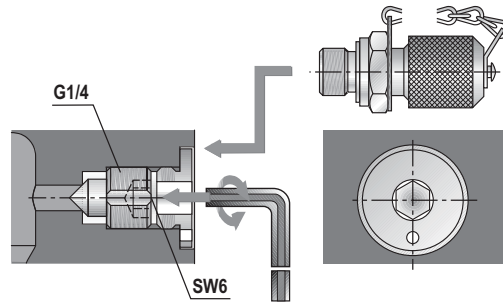

Scope of delivery: Measuring coupling **G1/4**
MESSKUPPLUNG AB 20-11/K1 G1/4 with seal ring of NBR
Material no. **R900009090**
MESSKUPPLUNG AB 20-11/K1V G1/4 with seal ring of FKM
Material no. **R900001264**

Dimensions: Throttle valve (dimensions in mm)

ØAL	40	50	63	80	100	125	140	160	180	200	220	250	280	320
Protrusion A ¹⁾	1	0	0	0	0	0	0	0	0	0	9.5	0	0	0
Nominal width	4	4	4	5	5	8	8	8	8	8	20	20	20	20

ØAL = Piston Ø

1) Throttle valve only with end position cushioning "E"
(180° for bleeding)
Protrusion A in closed condition

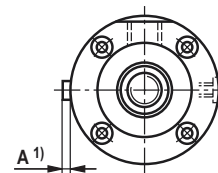

Bosch Rexroth AG, RE 17335, edition: 2014-03

Position measurement system

Types of mounting

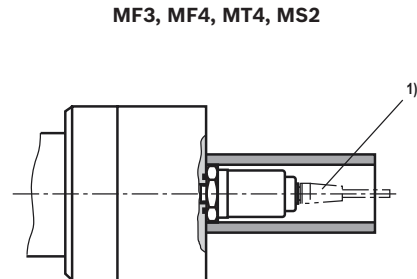
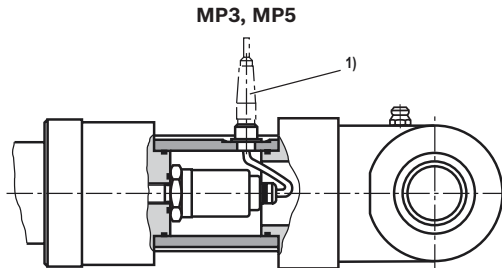

- ¹⁾ For analog output:
6-pole Amphenol mating connector, material no. **R900072231**
(mating connector is **not** included in the scope of delivery, must be ordered separately)



- ¹⁾ For digital output:
7-pole Amphenol mating connector, material no. **R900079551**
(mating connector is **not** included in the scope of delivery, must be ordered separately)



Pin assignment

Position measurement system (analog output)

Connector (view to pin side)

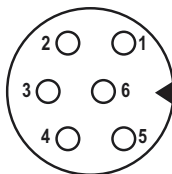

Pin	Cable	Signal/current	Signal/voltage
1	Gray	4 ... 20 mA	0 ... 10 V
2	Pink	DC ground	DC ground
3	Yellow	Not used	Not used
4	Green	DC ground	DC ground
5	Brown	+24 V DC (+20 %/-15 %)	+24 V DC (+20 %/-15 %)
6	White	DC ground (0 V)	DC ground (0 V)

Position measurement system (digital output)

Connector (view to pin side)

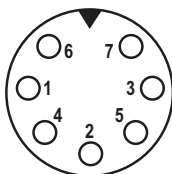

Pin	Cable	Signal/SSi
1	Gray	Data (-)
2	Pink	Data (+)
3	Yellow	Clock (+)
4	Green	Clock (-)
5	Brown	+24 V DC (+20 %/-15 %)
6	White	DC ground (0 V)
7	-	Not used

42/74 CDH2...XC / CGH2...XC / CSH2...XE | Hydraulic cylinders for explosive areas

Position measurement system

The position measurement system that is pressure-resistant up to 500 bar works in a contactless and absolute manner. The basis of this position measurement system is the magnetostrictive effect. Here, the coincidence of two magnetic fields triggers a torsional impulse.

This impulse runs on the wave guide inside the scale from the measuring point to the sensor head. The running time is constant and almost independent of temperature. It is proportional to the solenoid position and thus a measure for the actual position value and is converted within the sensor into a direct analog or digital output.

Technical data

(For applications outside these parameters, please consult us!)

Operating pressure	bar	250
Analog output	V	0 ... 10
	Load resistance	kΩ ≥ 5
	Resolution	Unlimited
Analog output	mA	4 ... 20
	Load resistance	Ω 0 ... 500
	Resolution	Unlimited
Digital output		SSI 24 bit gray-coded
	Resolution	μm 5
	Direction of measurement	Asynchronously forward
Linearity (absolute accuracy)	Analog	% ≤ ±0.02 % (referred to measurement length) mm min. ±0.05
	Digital	% ≤ ±0.01 % (referred to measurement length) mm min. ±0.04
Reproducibility	%	±0.001 (referred to measurement length)
	mm	min. ±0.0025
Hysteresis	mm	≤ 0.004
Supply voltage	V DC	24 (±10 % with analog output)
	Current consumption	mA 100
	Residual ripple	% s-s ≤ 1
	V DC	24 (+20 %/-15 % with digital output)
	Current consumption	mA 70
Protection class	Pipe and flange	IP 67
	Sensor electronics	IP 65
Operating temperature	Sensor electronics	°C -40 ... +75
Temperature coefficient	Voltage	ppm/°C 70
	Current	ppm/°C 90

Bosch Rexroth AG, RE 17335, edition: 2014-03

Hydraulic cylinders for explosive areas | **CDH2...XC / CGH2...XC / CSH2...XE** 43/74

Name plate

- | | |
|--------------------------------|--|
| 1 Word mark | 9 Customer or production order |
| 2 Material no. | 10 Customer's material number or additional information |
| 3 Material short text | 11 CE mark |
| 4 Serial number | 12 Explosion protection |
| 5 Area/works number | 13 EX mark 1 |
| 6 Date of production | 14 EX mark 2 |
| 7 Catalog no. | 15 Test stamp ¹⁾ |
| 8 Designation of origin | 16 Assembly stamp ¹⁾ |

¹⁾ Items 15 and 16 must be attached to the device.

Name plate for piston Ø 63 mm to 320 mm

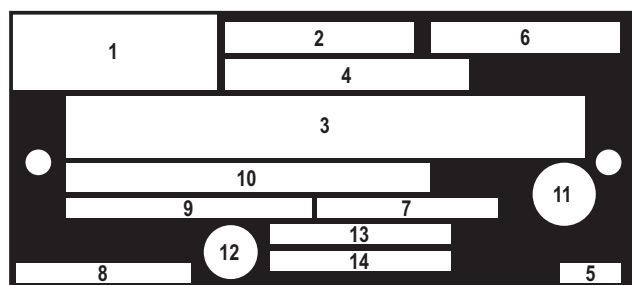

Name plate for piston Ø 40 mm to 50 mm

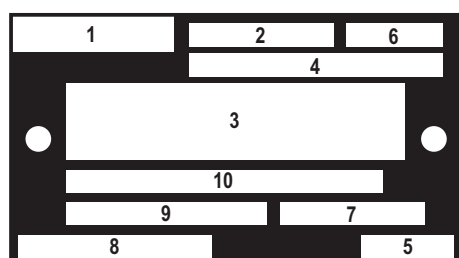

Separate adhesive label for ATEX units piston Ø 40 mm and 50 mm

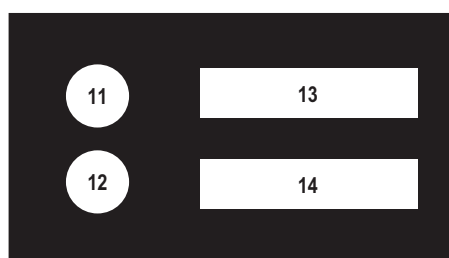

RE 17335-X, edition: 2014-03, **Bosch Rexroth AG**

44/74 CDH2...XC / CGH2...XC / CSH2...XE | Hydraulic cylinders for explosive areas

Dimensions: Equipotential bonding

(dimensions in mm)

Mounting ring for equipotential bonding at the piston rod

bonding at the piston rod

Piston Ø 40 ... 125 mm

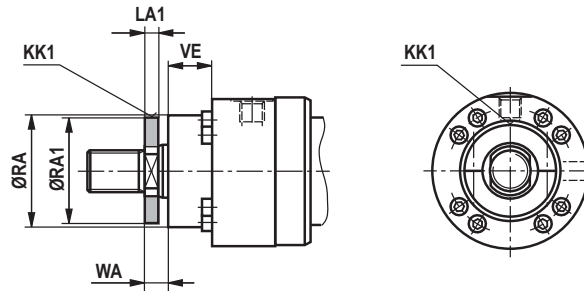

Equipotential bonding at the piston rod

Piston Ø 140 ... 320 mm

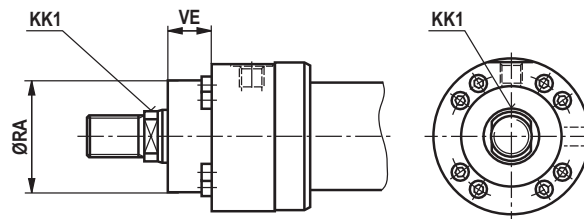

Equipotential bonding at the cylinder

Piston Ø 40 ... 320 mm

CDH2...XC

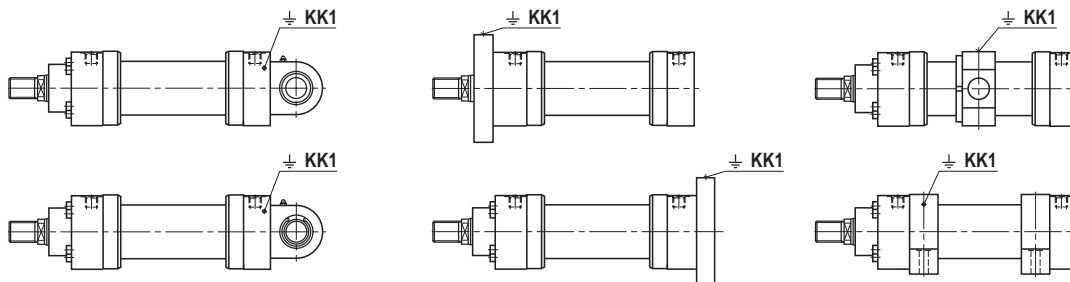

CGH2...XC

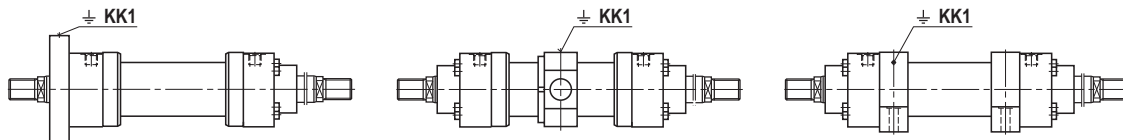

Bosch Rexroth AG, RE 17335, edition: 2014-03

Dimensions: Equipotential bonding
(dimensions in mm)

CSH2...XE

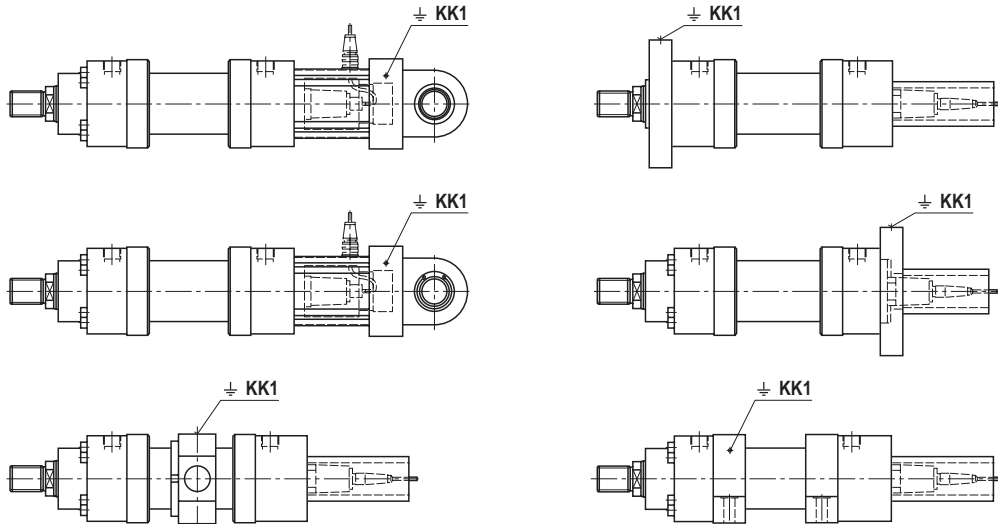

ØAL	ØMM	RA1	LA1	KK1
40	25	48	12	M6
	28	50		
50	32	56	12	M6
	36	60		
63	40	68	12	M6
	45	72		
80	50	80	13	M6
	56	85		
100	63	95	18	M6
	70	100		
125	80	110	18	M6
	90	120		
140 ... 320	-	-	-	M8

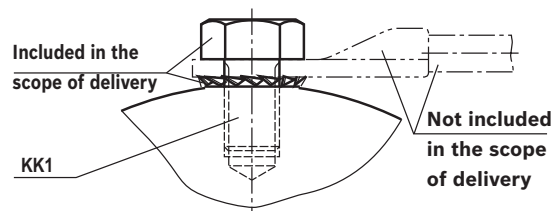

ØAL = Piston Ø
ØMM = Piston rod Ø

46/74 CDH2...XC / CGH2...XC / CSH2...XE | Hydraulic cylinders for explosive areas

Dimensions: Swivel head CGKD (clampable)
(dimensions in mm)

ISO 8132

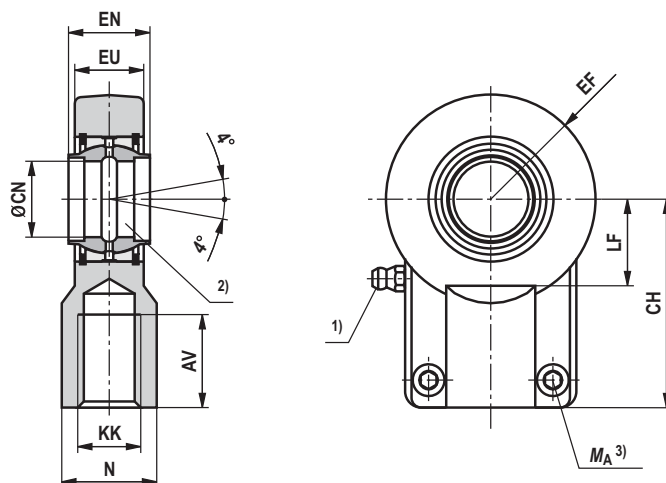

ØAL	ØMM	Type	Material no.	Nominal force kN	AV min.	N max.	CH js13	EF max.	ØCN H7 2)	EN h12	EU max.
40	25 / 28	CGKD 25	R900323332	32	29	31	65	32	25	25	22
50	32 / 36	CGKD 32	R900322049	50	37	38	80	40	32	32	28
63	40 / 45	CGKD 40	R900322029	80	46	47	97	50	40	40	34
80	50 / 56	CGKD 50	R900322719	125	57	58	120	63	50	50	42
100	63 / 70	CGKD 63	R900322028	200	64	70	140	72.5	63	63	53.5
125	80 / 90	CGKD 80	R900322700	320	86	91	180	92	80	80	68
140	90 / 100	CGKD 90 7)	R900325702	400	91	100	195	101	90	90	72
160	100 / 110	CGKD 100	R900322030	500	96	110	210	114	100	100	85.5
180	110 / 125	CGKD 110 7)	R900308153	635	106	125	235	129	110	110	88
200	125 / 140	CGKD 125	R900322026	800	113	135	260	160	125	125	105
220	140 / 160	CGKD 160	R900300718	1,520	126	165	310	200	160	160	133
250	160 / 180	CGKD 160	R900300718	1,520	126	165	310	200	160	160	133
280	180 / 200	CGKD 200	R900324814	2,000	161	215	390	250	200	200	165
320	200 / 220	CGKD 200	R900324814	2,000	161	215	390	250	200	200	165

Bosch Rexroth AG, RE 17335, edition: 2014-03

Dimensions: Swivel head CGKD (clampable)
(dimensions in mm)

ØAL	ØMM	Type	KK	LF min.	Clamping screw ISO 4762-10.9	M _A ³⁾ Nm	m ⁴⁾ kg	C ₀ ⁵⁾ kN	F _{adm} ⁶⁾ kN
40	25 / 28	CGKD 25	M20x1.5	25.5	M8x20	30	0.65	78	28.8
50	32 / 36	CGKD 32	M27x2	30	M10x25	59	1.15	114	42.1
63	40 / 45	CGKD 40	M33x2	39	M10x30	59	2.1	204	75.3
80	50 / 56	CGKD 50	M42x2	47	M12x35	100	4	310	114.4
100	63 / 70	CGKD 63	M48x2	58	M16x40	250	7.2	430	158.7
125	80 / 90	CGKD 80	M64x3	74	M20x50	490	15	695	256.5
140	90 / 100	CGKD 90 ⁷⁾	M72x3	85	M20x60	490	19	750	276.8
160	100 / 110	CGKD 100	M80x3	94	M24x60	840	25.5	1060	391.1
180	110 / 125	CGKD 110 ⁷⁾	M90x3	105	M24x60	840	36.5	1200	442.8
200	125 / 140	CGKD 125	M100x3	116	M24x70	840	52.5	1430	527.7
220	140 / 160	CGKD 160	M125x4	145	M24x80	840	82.5	2200	811.8
250	160 / 180	CGKD 160	M125x4	145	M24x80	840	82.5	2200	811.8
280	180 / 200	CGKD 200	M160x4	190	M30x100	1700	168	3650	1346.9
320	200 / 220	CGKD 200	M160x4	190	M30x100	1700	168	3650	1346.9

Note:

Geometry and dimensions may differ depending on the manufacturer. In case of combination with other mounting elements, the usability must be checked.

ØAL =Piston Ø

ØMM =Piston rod Ø

¹⁾ Lubricating nipple, cone head form A according to DIN 71412

²⁾ Bolt Ø m6 required

³⁾ M_A =Tightening torque

The swivel head must always be screwed against the shoulder of the piston rod. Afterwards, the clamping screws must be tightened with the specified tightening torque.

⁴⁾ m = Weight swivel head in kg

⁵⁾ C₀ = Static load rating of the swivel head

⁶⁾ F_{adm} = Max. admissible load of the swivel head with oscillatory or alternating loads

⁷⁾ Not contained in the standard

Dimensions: Fork clevis CCKB (clampable) (dimensions in mm)

ISO 8132

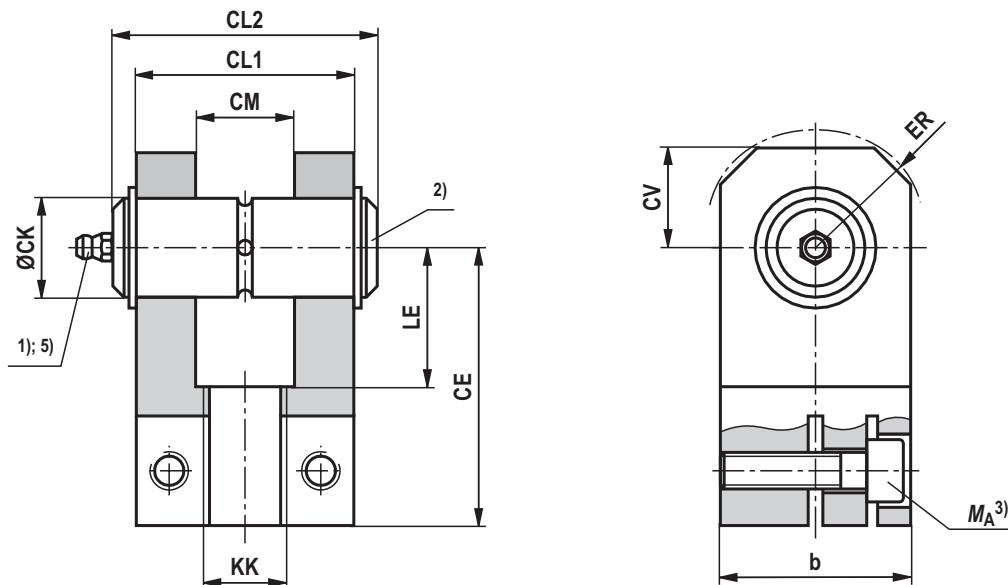

ØAL	ØMM	Type	Material no.	Nominal force kN	b max.	CE js13	ØCK H9 2)	CL1 h16	CL2 max.	CM A13	ER max.
40	25 / 28	CCKB 25	R900542845	32	50	65	25	56	84	25	32
50	32 / 36	CCKB 32	R900542846	50	65	80	32	70	105	32	40
63	40 / 45	CCKB 40	R900542847	80	80	97	40	90	133	40	50
80	50 / 56	CCKB 50	R900542848	125	100	120	50	110	165	50	63
100	63 / 70	CCKB 63	R900542849	200	140	140	63	140	185	63	71
125	80 / 90	CCKB 80	R900542850	320	180	180	80	170	225	80	90
140	90 / 100	CCKB 90	6)	400	200	195	90	190	6)	90	100
160	100 / 110	CCKB 100	6)	500	220	210	100	210	6)	100	110

Dimensions: Fork clevis CCKB (clampable) (dimensions in mm)

ØAL	ØMM	Type	KK	LE min.	CV max.	Clamping screw ISO 4762-10.9	M _A ³⁾ Nm	m ⁴⁾ kg
40	25 / 28	CCKB 25	M20x1.5	34	32	M10x35	49	1.4
50	32 / 36	CCKB 32	M27x2	41	40	M12x40	85	2.8
63	40 / 45	CCKB 40	M33x2	51	50	M16x50	210	5.2
80	50 / 56	CCKB 50	M42x2	63	63	M20x60	425	9.5
100	63 / 70	CCKB 63	M48x2	75	71	M24x80	730	21.5
125	80 / 90	CCKB 80	M64x3	94	90	M30x100	1450	38.2
140	90 / 100	CCKB 90	M72x3	108	100	M36x120	2480	⁶⁾
160	100 / 110	CCKB 100	M80x3	114	110	M36x130	2480	⁶⁾

Note:

Geometry and dimensions may differ depending on the manufacturer. In case of combination with other mounting elements, the usability must be checked.

ØAL = Piston Ø

ØMM = Piston rod Ø

¹⁾ Lubricating nipple, cone head form A according to DIN 71412

²⁾ Bolt Ø m6 required (bolt and bolt lock are included in the scope of delivery and are not mounted upon delivery)

³⁾ M_A = Tightening torque

The fork clevis must always be screwed against the shoulder of the piston rod. Afterwards, the clamping screws must be tightened with the specified tightening torque.

⁴⁾ m = Weight of the fork clevis in kg

⁵⁾ Without lubrication bore

⁶⁾ Upon request

Dimensions: Trunnion bearing block CLTB (dimensions in mm)

ISO 8132

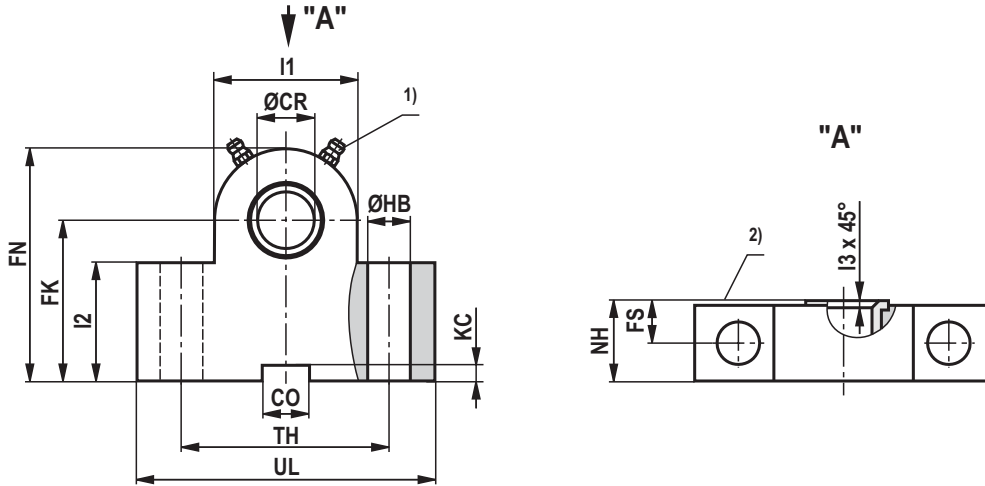

ØAL	Type ³⁾	Material no.	Nominal force kN ⁴⁾	ØCR H7	CO N9	FK js12	FN max.	FS js14	ØHB H13	KC +0.3
40	CLTB 25	R900772610	32	25	25	55	80	12	13.5	5.4
50	CLTB 32	R900772611	50	32	25	65	100	15	17.5	5.4
63	CLTB 40	R900772612	80	40	36	76	120	16	22	8.4
80	CLTB 50	R900772613	125	50	36	95	140	20	26	8.4
100	CLTB 63	R900772614	200	63	50	112	180	25	33	11.4
125	CLTB 80	R900772615	320	80	50	140	220	31	39	11.4
140	CLTB 90	R901364220	385	90	63	160	250	40	45	12.4
160	CLTB 100	R901205929	500	100	63	180	280	45	52	12.4
180	CLTB 110	R901364223	630	110	80	200	310	50	52	15.4

Dimensions: Trunnion bearing block CLTB (dimensions in mm)

ØAL	Type ³⁾	l1	l2	l3	NH max.	TH js14	UL max.	m ⁵⁾ kg
40	CLTB 25	56	45	1.5	26	80	110	2.1
50	CLTB 32	70	52	2	33	110	150	4.55
63	CLTB 40	88	60	2.5	41	125	170	7.3
80	CLTB 50	100	75	2.5	51	160	210	14.5
100	CLTB 63	130	85	3	61	200	265	23.1
125	CLTB 80	160	112	3.5	81	250	325	52.3
140	CLTB 90	180	130	4	91	265	345	⁶⁾
160	CLTB 100	200	145	4.5	102	295	385	100
180	CLTB 110	220	160	5	112	320	410	⁶⁾

Note:

Geometry and dimensions may differ depending on the manufacturer. In case of combination with other mounting elements, the usability must be checked.

The trunnion bearing blocks are suitable for attachment in case of type of mounting MT4.

ØAL = Piston Ø

- 1) Lubricating nipple, cone head form A according to DIN 71412
- 2) Contact surface trunnion (inside)
- 3) Bearing blocks are always supplied in pairs
- 4) Nominal force applies to applications in pairs
- 5) **m** = Weight of trunnion bearing block in kg (specified per pair)
- 6) Upon request

Dimensions: Clevis bracket CLCA (dimensions in mm)

ISO 8132, form B

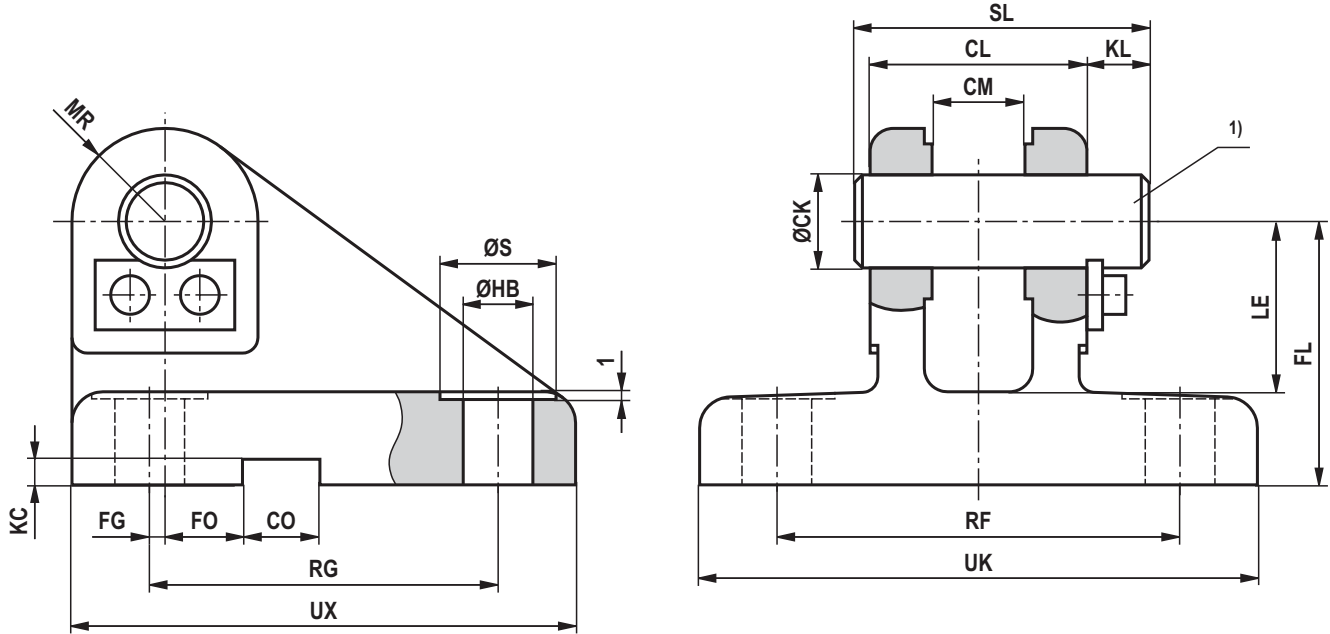

ØAL	ØMM	Type	Material no.	Nominal force kN	ØCK H9 1)	CL h16	CM A12	CO N9	FG js14	FL js12	FO js14
40	25 / 28	CLCA 25	R900542864	32	25	56	25	25	10	55	10
50	32 / 36	CLCA 32	R900542865	50	32	70	32	25	14.5	65	6
63	40 / 45	CLCA 40	R900542866	80	40	90	40	36	17.5	76	6
80	50 / 56	CLCA 50	R900542867	125	50	110	50	36	25	95	0
100	63 / 70	CLCA 63	R900542868	200	63	140	63	50	33	112	0
125	80 / 90	CLCA 80	R900542869	320	80	170	80	50	45	140	0
140	90 / 100	CLCA 90	3)	400	90	190	90	63	47.5	160	0
160	100 / 110	CLCA 100	3)	500	100	210	100	63	52.5	180	0
180	110 / 125	CLCA 110	3)	635	110	240	110	80	62.5	200	0
200	125 / 140	CLCA 125	3)	800	125	270	125	80	75	230	0

Dimensions: Clevis bracket CLCA (dimensions in mm)

ØAL	ØMM	Type	ØHB H13	KC +0.3	KL	LE min.	MR max.	RF js14	RG js14	ØS	SL	UK max.	UX max.	m ²⁾ kg
40	25 / 28	CLCA 25	13.5	5.4	10	37	25	90	85	20	69	120	115	3
50	32 / 36	CLCA 32	17.5	5.4	13	43	32	110	110	26	87	145	145	5
63	40 / 45	CLCA 40	22	8.4	16	52	40	140	125	33	110	185	170	9.6
80	50 / 56	CLCA 50	26	8.4	19	65	50	165	150	40	133	215	200	15.5
100	63 / 70	CLCA 63	33	11.4	20	75	63	210	170	48	164	270	230	27.5
125	80 / 90	CLCA 80	39	11.4	26	95	80	250	210	57	202	320	280	47
140	90 / 100	CLCA 90	45	12.4	28	108	90	280	235	66	224	360	320	³⁾
160	100 / 110	CLCA 100	52	12.4	30	120	100	315	250	76	246	405	345	³⁾
180	110 / 125	CLCA 110	52	15.4	31	138	110	335	305	76	277	425	400	³⁾
200	125 / 140	CLCA 125	52	15.4	32	170	125	365	350	76	310	455	450	³⁾

Note:

Geometry and dimensions may differ depending on the manufacturer. In case of combination with other mounting elements, the usability must be checked.

ØAL = Piston Ø

ØMM = Piston rod Ø

¹⁾ Bolt Ø m6 required (bolt and bolt lock are included in the scope of delivery and are not mounted upon delivery)

²⁾ **m** = Weight of clevis bracket in kg

³⁾ Upon request

Dimensions: Clevis bracket CLCD (dimensions in mm)

ISO 8132, form A

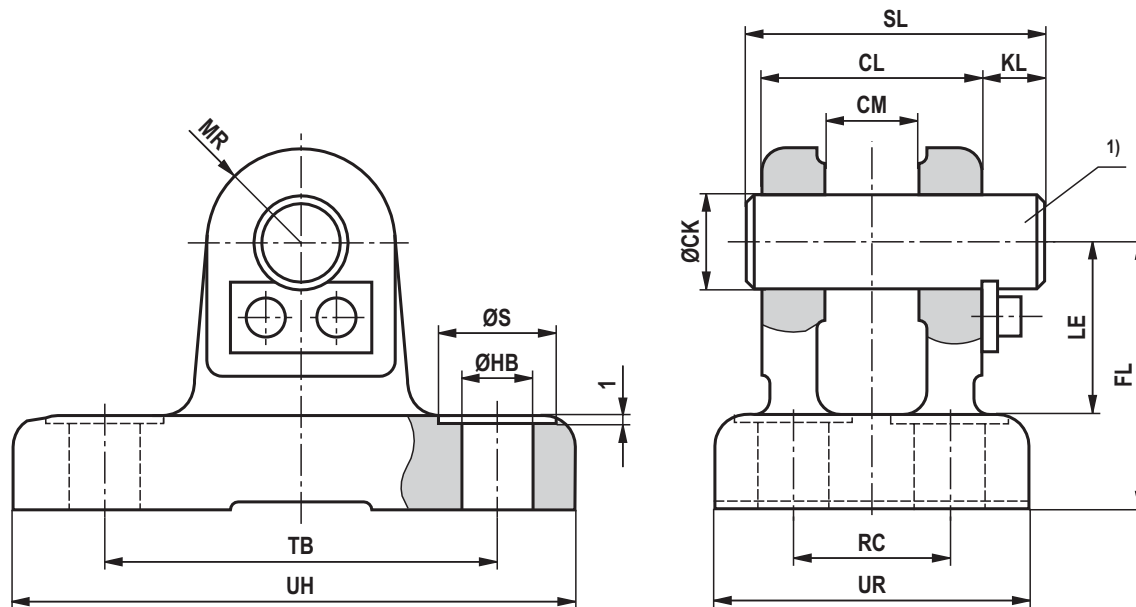

ØAL	ØMM	Type	Material no.	Nominal force kN	ØCK H9 1)	CL h16	CM A13	FL js12	ØHB H13	KL
40	25 / 28	CLCD 25	R900542882	32	25	56	25	55	13.5	10
50	32 / 36	CLCD 32	R900542883	50	32	70	32	65	17.5	13
63	40 / 45	CLCD 40	R900542884	80	40	90	40	76	22	16
80	50 / 56	CLCD 50	R900542885	125	50	110	50	95	26	19
100	63 / 70	CLCD 63	R900542886	200	63	140	63	112	33	20
125	80 / 90	CLCD 80	R900542887	320	80	170	80	140	39	26
140	90 / 100	CLCD 90	3)	400	90	190	90	160	45	28
160	100 / 110	CLCD 100	3)	500	100	210	100	180	45	30
180	110 / 125	CLCD 110	3)	635	110	240	110	200	52	31
200	125 / 140	CLCD 125	3)	800	125	270	125	230	52	32

Dimensions: Clevis bracket CLCD (dimensions in mm)

ØAL	ØMM	Type	LE min.	MR max.	RC js14	ØS	SL	TB js14	UR max.	UH max.	m ²⁾ kg
40	25 / 28	CLCD 25	37	25	40	20	69	85	70	113	1.9
50	32 / 36	CLCD 32	43	32	50	26	87	110	85	143	3
63	40 / 45	CLCD 40	52	40	65	33	110	130	108	170	5.5
80	50 / 56	CLCD 50	65	50	80	40	133	170	130	220	10.6
100	63 / 70	CLCD 63	75	63	100	48	164	210	160	270	17
125	80 / 90	CLCD 80	95	80	125	57	202	250	210	320	32
140	90 / 100	CLCD 90	108	90	140	66	224	290	230	370	³⁾
160	100 / 110	CLCD 100	120	100	160	66	246	315	260	400	³⁾
180	110 / 125	CLCD 110	138	110	180	76	277	350	290	445	³⁾
200	125 / 140	CLCD 125	170	125	200	76	310	385	320	470	³⁾

Note:

Geometry and dimensions may differ depending on the manufacturer. In case of combination with other mounting elements, the usability must be checked.

ØAL = Piston Ø

ØMM = Piston rod Ø

¹⁾ Bolt Ø m6 required (bolt and bolt lock are included in the scope of delivery and are not mounted upon delivery)

²⁾ **m** = Weight of clevis bracket in kg

³⁾ Upon request

Kinking

For the admissible stroke length with flexibly guided load and a factor of 3.5 for safety against kinking, please refer to the relevant table. For other installation positions of the cylinder, the admissible stroke length must be interpolated. Admissible stroke length for non-guided load on request. Kinking calculations are carried out according to the following formulas:

1. Calculation according to Euler

$$F = \frac{\pi^2 \cdot E \cdot I}{\nu \cdot L_K^2} \quad \text{if } \lambda > \lambda_g$$

2. Calculation according to Tetmajer

$$F = \frac{d^2 \cdot \pi (335 - 0.62 \cdot \lambda)}{4 \cdot \nu} \quad \text{if } \lambda \leq \lambda_g$$

Explanation:

E = Module of elasticity in N/mm²

= 2.1 x 10⁵ for steel

I = Geometrical moment of inertia in mm⁴

for circular cross-section = $\frac{d^4 \cdot \pi}{64} = 0.0491 \cdot d^4$

ν = 3.5 (safety factor)

L_K = Free kinking length in mm (depending on the type of mounting see sketches A, B, C)

d = Piston rod Ø in mm

λ = Slenderness ratio

$$= \frac{4 \cdot L_K}{d} \quad \lambda_g = \pi \sqrt{\frac{E}{0.8 \cdot R_e}}$$

R_e = Yield strength of the piston rod material

Influence of the type of mounting on the kinking length:

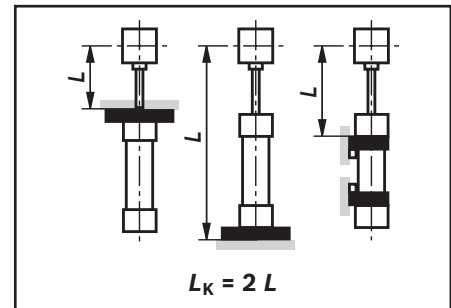
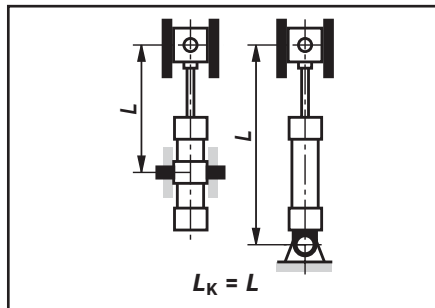
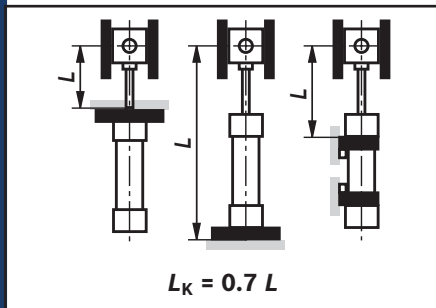

Admissible stroke length (dimensions in mm)

Type of mounting CDH2...XC / CSH2...XE ²⁾: MP3, MP5

ØAL	ØMM	Admissible stroke length with									Installation position
		100 bar			160 bar			250 bar			
		0°	45°	90°	0°	45°	90°	0°	45°	90°	
40	25	195	200	215	130	135	140	40	45	55	<div style="display: flex; flex-direction: column; align-items: center;"> <div style="margin-bottom: 20px;"> <p>0°</p> </div> <div style="margin-bottom: 20px;"> <p>45°</p> </div> <div> <p>90°</p> </div> </div> <p>¹⁾ Adm. stroke length</p>
	28	385	400	445	295	300	320	215	220	225	
50	32	380	390	430	280	285	300	195	200	205	
	36	505	525	595	395	405	430	290	295	305	
63	40	480	500	550	365	370	385	255	260	265	
	45	640	660	750	505	515	550	380	385	395	
80	50	590	615	690	455	465	495	330	335	345	
	56	765	800	930	615	630	685	470	475	495	
100	63	750	780	910	595	610	660	445	455	470	
	70	940	985	1195	775	800	885	605	615	650	
125	80	970	1015	1200	780	805	880	595	605	635	
	90	1235	1300	1610	1030	1070	1200	825	840	895	
140	90	1075	1130	1360	875	905	1000	675	685	725	
	100	1335	1405	1770	1120	1165	1325	900	920	985	
160	100	1175	1230	1480	955	985	1085	735	750	785	
	110	1430	1500	1875	1195	1240	1400	955	975	1040	
180	110	1250	1310	1570	1010	1045	1150	775	790	830	
	125	1620	1710	2160	1365	1420	1620	1100	1125	1205	
200	125	1435	1510	1860	1180	1220	1365	915	935	990	
	140	1795	1900	2450	1525	1590	1840	1240	1270	1370	
220	140	1620	1710	2180	1360	1415	1630	1090	1120	1200	
	160	2075	2200	3000	1810	1890	2280	1510	1560	1730	
250	160	1805	1910	2490	1520	1590	1850	1220	1250	1360	
	180	2250	2395	3300	1960	2060	2500	1630	1690	1880	
280	180	2075	2200	2900	1775	1880	2170	1450	1490	1620	
	200	2510	2670	3700	2200	2310	2820	1850	1920	2140	
320	200	2135	2270	3030	1820	1900	2260	1470	1510	1660	
	220	2550	2720	3820	2230	2340	2880	1860	1930	2170	

Admissible stroke length (dimensions in mm)

Type of mounting CDH2...XC / CGH2...XC / CSH2...XE 2): MF3

ØAL	ØMM	Admissible stroke length with									Installation position
		100 bar			160 bar			250 bar			
		0°	45°	90°	0°	45°	90°	0°	45°	90°	
40	25	895	915	980	730	735	760	440	450	510	
	28	1400	1415	1630	1180	1205	1275	970	980	1010	
50	32	1440	1490	1670	1210	1230	1300	985	995	1025	
	36	1760	1830	2000	1510	1545	1675	1255	1270	1320	
63	40	1735	1800	2000	1475	1510	1620	1215	1230	1270	
	45	2000	2000	2000	1830	1880	2080	1540	1560	1640	
80	50	2000	2000	2000	1810	1850	1995	1495	1515	1570	
	56	2000	2000	2000	2000	2000	2000	1870	1900	2000	
100	63	2580	2690	3000	2235	2300	2550	1875	1910	2010	
	70	3000	3000	3000	2690	2780	3000	2300	2350	2520	
125	80	3000	3000	3000	2840	2930	3000	2400	2450	2590	
	90	3000	3000	3000	3000	3000	3000	3000	3000	3000	
140	90	3000	3000	3000	3000	3000	3000	2700	2760	2950	
	100	3000	3000	3000	3000	3000	3000	3000	3000	3000	
160	100	3000	3000	3000	3000	3000	3000	2920	2980	3000	
	110	3000	3000	3000	3000	3000	3000	3000	3000	3000	
180	110	3000	3000	3000	3000	3000	3000	3000	3000	3000	
	125	3000	3000	3000	3000	3000	3000	3000	3000	3000	
200	125	3000	3000	3000	3000	3000	3000	3000	3000	3000	
	140	3000	3000	3000	3000	3000	3000	3000	3000	3000	
220	140	5400	5680	6000	4800	4980	5780	4120	4220	4560	
	160	6000	6000	6000	5820	6000	6000	5150	5330	6000	
250	160	5850	6000	6000	5270	5500	6000	4600	4740	5250	
	180	6000	6000	6000	6000	6000	6000	5650	5850	6000	
280	180	6000	6000	6000	6000	6000	6000	5270	5420	5970	
	200	6000	6000	6000	6000	6000	6000	6000	6000	6000	
320	200	6000	6000	6000	6000	6000	6000	5950	6000	6000	
	220	6000	6000	6000	6000	6000	6000	6000	6000	6000	

Type of mounting CDH2...XC / CSH2...XE 2): MF4

ØAL	ØMM	Admissible stroke length with									Installation position
		100 bar			160 bar			250 bar			
		0°	45°	90°	0°	45°	90°	0°	45°	90°	
40	25	325	340	370	245	250	260	105	110	140	
	28	565	590	695	465	475	520	365	370	385	
50	32	600	625	715	485	495	530	370	375	390	
	36	755	790	950	630	650	715	505	515	540	
63	40	730	765	905	600	615	675	470	480	500	
	45	920	965	1190	780	805	905	630	645	685	
80	50	910	950	1130	750	775	845	595	605	630	
	56	1125	1185	1470	960	990	1120	785	800	850	
100	63	1120	1175	1460	945	980	1105	770	785	835	
	70	1350	1430	1860	1175	1220	1420	980	1000	1090	
125	80	1430	1510	1910	1225	1270	1450	1000	1025	1100	
	90	1750	1855	2490	1540	1610	1910	1300	1340	1470	
140	90	1585	1675	2170	1370	1425	1650	1135	1165	1260	
	100	1895	2010	2750	1675	1755	2110	1425	1470	1630	
160	100	1725	1820	2340	1490	1545	1780	1230	1260	1360	
	110	2030	2150	2900	1785	1870	2230	1510	1560	1720	
180	110	1855	1960	2510	1595	1660	1910	1315	1350	1450	
	125	2300	2440	3350	2040	2130	2580	1735	1790	1990	
200	125	2105	2230	2950	1830	1910	2250	1530	1570	1715	
	140	2535	2700	3000	2260	2370	2920	1940	2010	2255	
220	140	2250	2400	3350	1990	2090	2550	1685	1740	1950	
	160	2800	2990	4500	2530	2680	3480	2220	2310	2700	
250	160	2600	2770	3900	2310	2430	3000	1975	2040	2300	
	180	3130	3350	5050	2840	3000	3910	2500	2600	3040	
280	180	2850	3050	4400	2550	2680	3370	2190	2270	2600	
	200	3370	3610	5550	3070	3250	4300	2700	2820	3330	
320	200	3070	3270	4750	2750	2890	3650	2150	2460	2810	
	220	3560	3820	5850	3250	3430	4550	2860	2980	3530	

Admissible stroke length (dimensions in mm)

Type of mounting CDH2...XC / CGH2...XC / CSH2...XE 2): MT4 trunnion in cylinder center

ØAL	ØMM	Admissible stroke length with									Installation position
		100 bar			160 bar			250 bar			
		0°	45°	90°	0°	45°	90°	0°	45°	90°	
40	25	340	345	365	250	255	260	130	135	145	
	28	590	605	665	470	480	500	365	370	375	
50	32	600	615	670	470	480	495	355	360	365	
	36	770	795	890	625	635	670	485	490	505	
63	40	740	765	845	590	600	630	450	455	465	
	45	940	975	1115	770	790	845	610	620	640	
80	50	920	950	1055	735	750	790	570	575	590	
	56	1155	1195	1375	950	975	1045	755	765	790	
100	63	1145	1190	1365	940	960	1030	740	750	775	
	70	1400	1460	1740	1180	1210	1330	955	970	1015	
125	80	1470	1530	1780	1220	1250	1350	970	985	1020	
	90	1820	1910	2320	1550	1600	1780	1275	1300	1370	
140	90	1640	1710	2020	1370	1410	1540	1100	1120	1170	
	100	1980	2080	2570	1700	1755	1970	1400	1430	1515	
160	100	1780	1850	2180	1485	1520	1660	1190	1210	1260	
	110	2110	2210	2710	1800	1860	2080	1480	1510	1595	
180	110	1910	1990	2340	1590	1635	1780	1275	1295	1350	
	125	2405	2530	3000	2065	2130	2400	1710	1740	1850	
200	125	2180	2280	2740	1840	1890	2090	1490	1510	1590	
	140	2660	2800	3000	2300	2380	2720	1915	1960	2100	
220	140	2490	2510	3150	2050	2120	2400	1685	1720	1835	
	160	3000	3170	4230	2640	2750	3260	2240	2310	2530	
250	160	2730	2870	3640	2350	2440	2790	1950	1990	2140	
	180	3320	3520	4720	2940	3060	3650	2500	2570	2830	
280	180	3040	3210	4140	2640	2750	3170	2210	2260	2440	
	200	3620	3840	5210	3210	3360	4040	2750	2830	3140	
320	200	3250	3430	4455	2820	2930	3410	2360	2420	2620	
	220	3800	4030	5500	3370	3530	4250	2880	2970	3290	

Type of mounting CDH2...XC / CGH2...XC / CSH2...XE 2): MS2

ØAL	ØMM	Admissible stroke length with									Installation position
		100 bar			160 bar			250 bar			
		0°	45°	90°	0°	45°	90°	0°	45°	90°	
40	25	825	840	885	645	650	665	370	375	410	
	28	1305	1350	1535	1085	1110	1180	875	885	910	
50	32	1330	1375	1560	1095	1120	1190	875	885	910	
	36	1645	1715	2030	1395	1430	1560	1140	1160	1210	
63	40	1610	1670	1950	1345	1380	1490	1085	1100	1145	
	45	1980	2000	2000	1700	1750	1950	1410	1435	1510	
80	50	1980	2000	2000	1665	1710	1850	1350	1370	1425	
	56	2000	2000	2000	2000	2000	2000	1730	1760	1860	
100	63	2420	2535	3000	2080	2140	2390	1720	1750	1850	
	70	2880	3000	3000	2530	2630	3000	2140	2190	2360	
125	80	3000	3000	3000	2660	2750	3000	2220	2270	2410	
	90	3000	3000	3000	3000	3000	3000	2810	2890	3000	
140	90	3000	3000	3000	2970	3000	3000	2490	2550	2740	
	100	3000	3000	3000	3000	3000	3000	3000	3000	3000	
160	100	3000	3000	3000	3000	3000	3000	2690	2750	2950	
	110	3000	3000	3000	3000	3000	3000	3000	3000	3000	
180	110	3000	3000	3000	3000	3000	3000	2890	2960	3000	
	125	3000	3000	3000	3000	3000	3000	3000	3000	3000	
200	125	3000	3000	3000	3000	3000	3000	3000	3000	3000	
	140	3000	3000	3000	3000	3000	3000	3000	3000	3000	
220	140	5090	5370	6000	4490	4670	5470	3820	3910	4260	
	160	6000	6000	6000	5510	5800	6000	4850	5020	5750	
250	160	5520	5860	6000	4940	5170	6000	4270	4410	4920	
	180	6000	6000	6000	6000	6000	6000	5320	5520	6000	
280	180	6000	6000	6000	5700	5960	6000	4930	5070	5630	
	200	6000	6000	6000	6000	6000	6000	6000	6000	6000	
320	200	6000	6000	6000	5890	6000	6000	4750	5310	6000	
	220	6000	6000	6000	6000	6000	6000	6000	6000	6000	

With longer strokes, an extended guide and/or the use of guide rings may be reasonable for increasing the service life, depending on the respective application and installation position. Recommendation on request.

2) With CSH2...XE, observe the maximum stroke length "X*_{max.}", pages 26 to 37

Bosch Rexroth AG, RE 17335, edition: 2014-03

End position cushioning

End position cushioning:

The objective is to reduce the velocity of a moved mass, whose center of gravity lies on the cylinder axis to a level, at which neither the cylinder nor the machine into which the cylinder is installed is damaged. For velocities above 20 mm/s, we recommend the use of an end position cushioning feature, which absorbs energy without requiring the use of additional equipment. It must, however, always be verified whether end position cushioning is also required for lower velocities with large masses.

Damping capacity:

When decelerating masses via end position cushioning, the structural-inherent cushioning capacity must not be exceeded. Cylinders with end position cushioning can achieve their full damping capacity only over the entire stroke length.

With the adjustable end position cushioning version "E", a throttle valve is additionally provided when compared with version "D". End position cushioning version "E" allows cycle times to be optimized. The max. damping capacity can only be achieved when the throttle valve is closed.

Formulas:

$$D_m = \frac{m}{10K} ; K = kv(0.5-v)$$

m = Moved weight in kg

v = Stroke velocity in m/s

kv = See table page 60

Extension for CDH2...XC and CSH2...XE

$$D_p = p_s - \frac{m \cdot 9.81 \cdot \sin \alpha}{A_1 \cdot 10}$$

Retraction for CDH2...XC, CGH2...XC and CSH2...XE;

Extension for CGH2...XC

$$D_p = p_s + \frac{m \cdot 9.81 \cdot \sin \alpha}{A_3 \cdot 10}$$

p_s = System pressure in bar

A_1 = Piston area in cm² (see page 11)

A_3 = Annulus area in cm² (see page 11)

α = Angle to the horizontal in degree

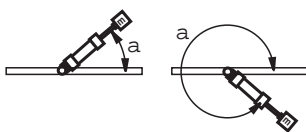

The calculation depends on the factors weight, velocity, system pressure and installation position. For this reason, mass and velocity are used to determine the characteristic D_m and system pressure and installation position to determine the characteristic D_p .

These two characteristics are used for verifying the admissible damping capacity in the "damping capacity" diagram. The intersection point of the characteristics D_m and D_p must always be below the damping capacity curve of the selected cylinder. The values in the diagrams refer to an average oil temperature of +45 to +65 °C with the throttle valve being closed.

For special applications with very short stroke times, high velocities or large masses, cylinders with special end position cushioning versions can be offered on request. When fixed or adjustable stops are used, special measures must be taken!

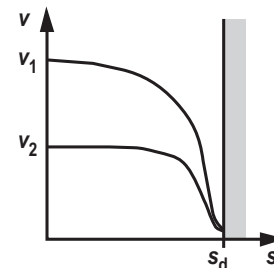
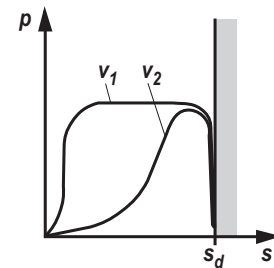
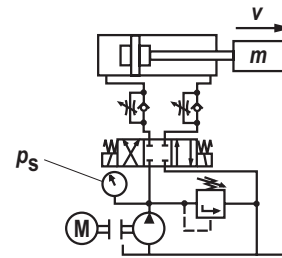

Damping length

ØAL mm	40	50	63	80	100	125	140	160	180	200	220	250	280	320
Head side	21	20	23	25	25	25	33	33	37	37	76	81	86	90
Base side	21	20	23	25	25	25	33	33	37	37	76	81	86	90

End position cushioning

ØAL mm	40	50	63	80	100	125	140	160	180	200	220	250	280	320
kv ①	2.85	2.97	2.56	2.82	3.51	3.02	2.53	2.65	2.91	2.76	2.85	2.95	3.11	3.13
kv ②	3.1	3.25	2.85	2.85	3.52	2.91	2.53	2.93	2.95	2.95	2.93	3.1	3.12	3.07
kv ③	2.95	3.1	2.73	3.1	3.51	2.95	2.51	2.91	2.95	2.91	2.93	2.93	3.15	3.25

Damping capacity: Extension for CDH2...XC and CSH2...XE, with kv ①

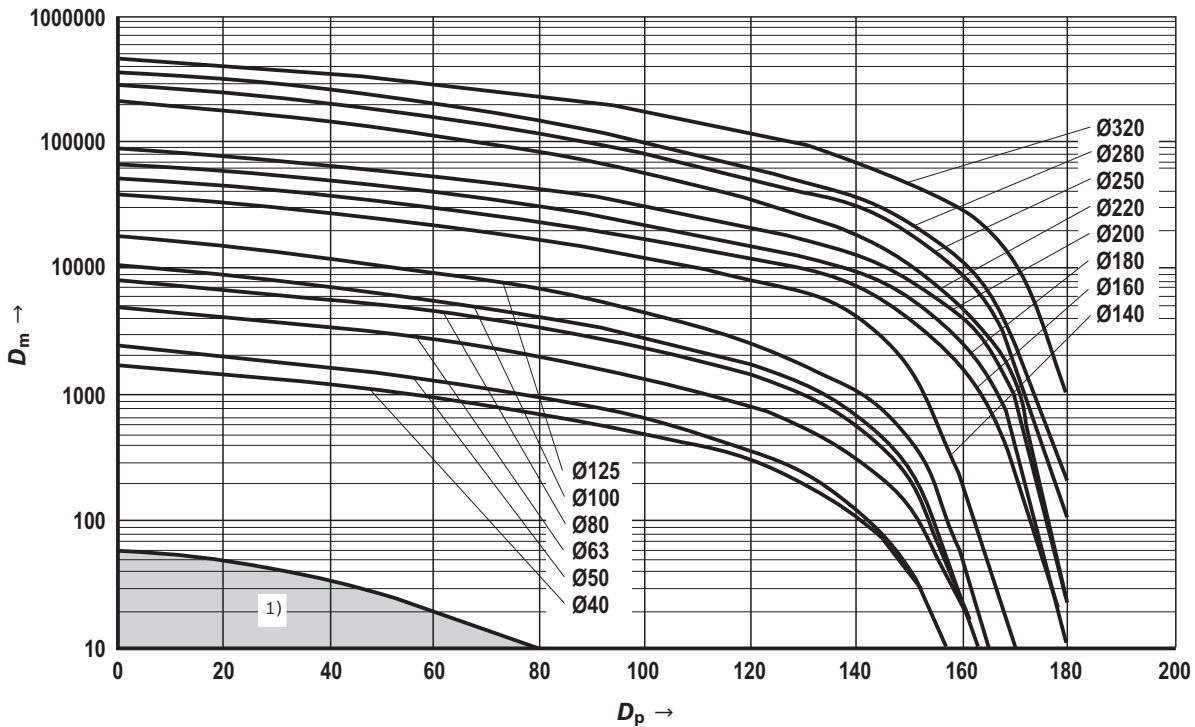

ØAL = Piston Ø

1) If with standard applications the calculated intersection point of D_m and D_p is within the marked area, we recommend designing the cylinder without end position cushioning.

End position cushioning

Damping capacity: Retraction for CDH2...XC, CGH2...XC and CSH2...XE; extension for CGH2...XC with k_v ②

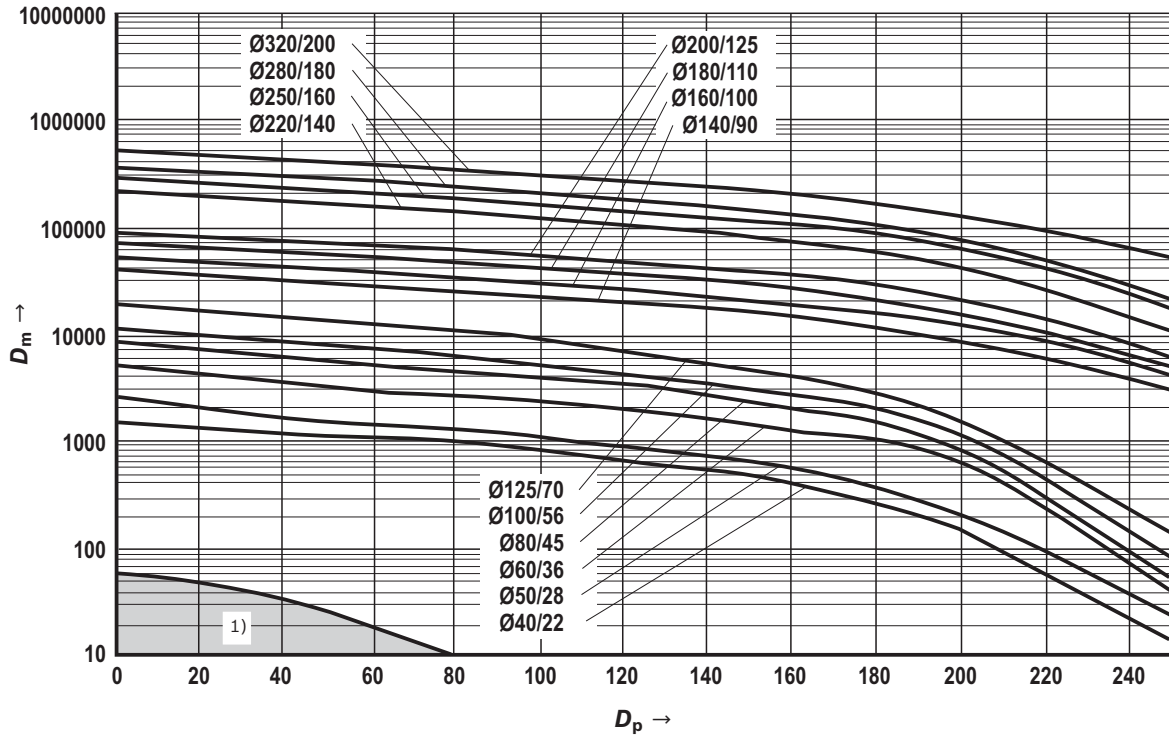

Damping capacity: Retraction for CDH2...XC, CGH2...XC and CSH2...XE; extension for CGH2...XC with k_v ③

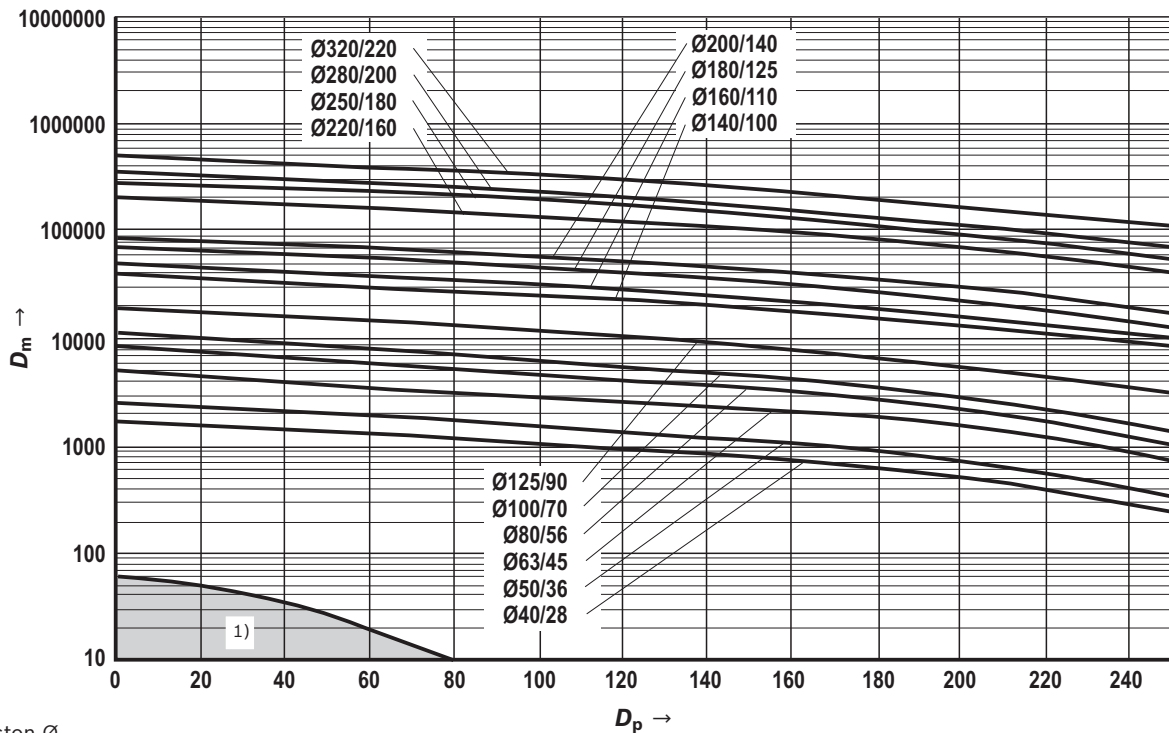

ØAL = Piston Ø

1) If with standard applications the calculated intersection point of D_m and D_p is within the marked area, we recommend designing the cylinder without end position cushioning.

Selection criteria for seals

Work and environmental conditions		Seal versions				
		M	A	B	T	S
Medium/temperature	Medium HL, HLP/operating temperature medium -20 °C to +80 °C	++	++	++	++	++
	Medium HFA/operating temperature medium +5 °C to +55 °C	+/-	+	+/-	++	+/-
	Medium HFC/operating temperature medium -20 °C to +60 °C	-	+/-	-	++	-
	Medium HFD-R/operating temperature medium -15 °C to +80 °C	-	-	++	-	++
	Ambient and rod temperature in the area of the piston rod from -20 °C to +80 °C ¹⁾	++	++	+ ²⁾	+	++ ²⁾
Function/velocity...	Static holding function more than 10 minutes: Attention! Application- and temperature-dependent	++	++	++	+	+
	Static holding function short-term < 1 minute	++	++	++	++	++
	Robust application conditions: Steel works, mining, thin ice	++	++	++	-	-
	Zero point control, hardly any amplitude, frequency max. 5 Hz, not longer than 5 minutes	-	-	-	++	++
	Cylinder velocity min. 0.001 m/sec stick-slip behavior	++	-	-	++	++
	Cylinder velocity from 0.01 m/sec to 0.5 m/sec ³⁾	++	+	+	++	++
	Cylinder velocity > 0.5 m/sec to max. 0.8 m/sec ³⁾	-	-	-	++	++
	Stroke > 1.0 m	+/-	++	++	++	++
	Standstill period (wear)	++	+/-	-	++	++
	Undissolved air in the oil ⁴⁾	-	-	-	+	+

++ = Very good

+ = Good

+/- = Conditional, depending on the application parameters

- = Unsuitable

General technical data in corresponding data sheets will remain valid!

Generally, a medium temperature of approx. 40 °C is recommended. The specified values are to be regarded as guidelines; depending on the application, it may be necessary to check the suitability of the seal system.

¹⁾ Moreover, observe the corresponding medium temperature range

²⁾ Lower temperature limit -15 °C

³⁾ Standard line connections not designed for that velocity

⁴⁾ - seal is destroyed/+ seal is not directly destroyed, leakage may occur

Seal kits

CDH2...XC – Standard

ØAL	ØMM	Material no. for seal design				
		M	A	B	T	S
40	25	R901010141	R901010145	R901010147	R901010143	R901010146
	28	R900851087	R900859445	R900859770	R900858841	R900861001
50	32	R900860274	R900860929	R900860939	R900860275	R900861003
	36	R900849392	R900851515	R900860940	R900860277	R900861004
63	40	R900859509	R900851637	R900860941	R900860279	R900861006
	45	R900847956	R900851638	R900859678	R900847855	R900861007
80	50	R900857129	R900856092	R900860943	R900860281	R900861009
	56	R900850905	R900854718	R900851205	R900856180	R900861010
100	63	R900860283	R900856093	R900860945	R900860284	R900861012
	70	R900853382	R900856094	R900860946	R900860285	R900861013
125	80	R900860287	R900860931	R900860950	R900860288	R900861015
	90	R900857949	R900856095	R900855464	R900856102	R900861016
140	90	R900858281	R900860932	R900860951	R900860289	R900861017
	100	R900853965	R900856096	R900860952	R900860290	R900849080
160	100	R900855683	R900860468	R900860953	R900860291	R900861018
	110	R900851146	R900860933	R900860954	R900857536	R900861019
180	110	R900856497	R900860934	R900860955	R900852561	R900861020
	125	R900848603	R900860935	R900860956	R900860292	R900861021
200	125	R900860294	R900860936	R900860957	R900860295	R900861022
	140	R900856431	R900860937	R900860958	R900860293	R900861023
220	140	R900888100	R900888116	R900888140	R900888108	R900888132
	160	R900888101	R900888117	R900888141	R900888109	R900888133
250	160	R900888102	R900888118	R900888142	R900888110	R900888134
	180	R900888103	R900888119	R900888143	R900888111	R900888135
280	180	R900888104	R900888120	R900888144	R900888112	R900888136
	200	R900888105	R900888121	R900888145	R900888113	R900888137
320	200	R900888106	R900888122	R900888146	R900888114	R900888138
	220	R900888107	R900888123	R900888147	R900888115	R900888139

ØAL = Piston Ø

ØMM = Piston rod Ø

Seal kits

CGH2...XC – Standard

ØAL	ØMM	Material no. for seal design				
		M	A	B	T	S
40	25	R901010159	R901010162	R901010170	R901010161	R901010169
	28	R900867252	R900866747	R900867133	R900868889	R900868943
50	32	R900867254	R900866749	R900857135	R900868891	R900868945
	36	R900864930	R900866750	R900867136	R900868892	R900868946
63	40	R900867261	R900866752	R900867138	R900868894	R900868948
	45	R900867262	R900866753	R900867139	R900868895	R900868949
80	50	R900867264	R900866755	R900867141	R900868897	R900868951
	56	R900867265	R900866756	R900867142	R900868898	R900868952
100	63	R900867267	R900866758	R900867144	R900868900	R900868954
	70	R900867268	R900866759	R900867146	R900868901	R900868955
125	80	R900860730	R900866761	R900867148	R900868903	R900868956
	90	R900867270	R900866762	R900867149	R900868904	R900868957
140	90	R900867271	R900866763	R900867150	R900868905	R900868958
	100	R900867272	R900866764	R900867151	R900868906	R900868959
160	100	R900867273	R900866765	R900867152	R900868907	R900868960
	110	R900867274	R900866766	R900867153	R900868908	R900868961
180	110	R900867275	R900866767	R900867154	R900868909	R900868962
	125	R900867276	R900866768	R900867155	R900868910	R900868963
200	125	R900867277	R900866769	R900867156	R900868911	R900868964
	140	R900867278	R900866770	R900867157	R900868912	R900868965
220	140	R900888020	R900888036	R900888060	R900888028	R900888052
	160	R900888021	R900888037	R900888061	R900888029	R900888053
250	160	R900888022	R900888038	R900888062	R900888030	R900888054
	180	R900888023	R900888039	R900888063	R900888031	R900888055
280	180	R900888024	R900888040	R900888064	R900888032	R900888056
	200	R900888025	R900888041	R900888065	R900888033	R900888057
320	200	R900888026	R900888042	R900888066	R900888034	R900888058
	220	R900888027	R900888043	R900888067	R900888035	R900888059

ØAL = Piston Ø

ØMM = Piston rod Ø

Seal kits

CDH2...XC – Standard + additional option F

ØAL	ØMM	Material no. for seal design		
		M+F	T+F	S+F
40	25	R901010148	R901010149	R901010150
	28	R900861025	R900861050	R900861100
50	32	R900861027	R900861052	R900861102
	36	R900861028	R900861053	R900861103
63	40	R900861030	R900861055	R900861105
	45	R900861031	R900861056	R900861106
80	50	R900861033	R900861058	R900861108
	56	R900861034	R900861059	R900861109
100	63	R900861036	R900861061	R900861114
	70	R900861037	R900861062	R900861115
125	80	R900861039	R900861064	R900861120
	90	R900861040	R900861065	R900861122
140	90	R900861041	R900861066	R900861124
	100	R900861042	R900861067	R900861126
160	100	R900861043	R900861068	R900861128
	110	R900861044	R900861069	R900861130
180	110	R900861045	R900861070	R900861133
	125	R900861046	R900861071	R900861135
200	125	R900861047	R900861072	R900861142
	140	R900861048	R900861073	R900861143

CGH2...XC – Standard + additional option F

ØAL	ØMM	Material no. for seal design		
		M+F	T+F	S+F
40	25	R901010151	R901010154	R901010156
	28	R900868999	R900869026	R900869093
50	32	R900869001	R900869028	R900869095
	36	R900869002	R900869029	R900869096
63	40	R900869004	R900869031	R900869098
	45	R900869005	R900869032	R900869099
80	50	R900869007	R900869034	R900869101
	56	R900869008	R900869035	R900869102
100	63	R900869012	R900869037	R900869104
	70	R900869013	R900869038	R900869105
125	80	R900869015	R900869040	R900869107
	90	R900869016	R900869041	R900869108
140	90	R900869017	R900869042	R900869109
	100	R900869018	R900869043	R900869110
160	100	R900869019	R900869044	R900869111
	110	R900869020	R900869045	R900869112
180	110	R900869021	R900869046	R900869113
	125	R900869022	R900869047	R900869114
200	125	R900869023	R900869048	R900869115
	140	R900869024	R900869049	R900869116

ØAL = Piston Ø

ØMM = Piston rod Ø

RE 17335-X, edition: 2014-03, Bosch Rexroth AG

Seal kits ²⁾

CSH2...XE

ØAL	ØMM	Material no. for seal design		
		M	T	S
40	28	R900861025	R900861050	R900861100
50	32	R900861027	R900861052	R900861102
	36	R900861028	R900861053	R900861103
63	40	R900861030	R900861055	R900861105
	45	R900861031	R900861056	R900861106
80	50	R900861033	R900861058	R900861108
	56	R900861034	R900861059	R900861109
100	63	R900861036	R900861061	R900861114
	70	R900861037	R900861062	R900861115
125	80	R900861039	R900861064	R900861120
	90	R900861040	R900861065	R900861122
140	90	R900861041	R900861066	R900861124
	100	R900861042	R900861067	R900861126
160	100	R900861043	R900861068	R900861128
	110	R900861044	R900861069	R900861130
180	110	R900861045	R900861070	R900861133
	125	R900861046	R900861071	R900861135
200	125	R900861047	R900861072	R900861142
	140	R900861048	R900861073	R900861143
220	140	R900888100	R900888108	R900888116
	160	R900888101	R900888109	R900888117
250	160	R900888102	R900888110	R900888118
	180	R900888103	R900888111	R900888119
280	180	R900888104	R900888112	R900888120
	200	R900888105	R900888113	R900888121
320	200	R900888106	R900888114	R900888122
	220	R900888107	R900888115	R900888123

Only for position measurement system

ØAL	Material no. for seal design	
	M, T	S
40	R900885935	R900885937
50	R900894958	R900894979
63	R900894959	R900894980
80	R900894960	R900894981
100	R900894961	R900894982
125	R900894962	R900894983
140	R900894963	R900894985
160	R900894964	R900894986
180	R900894973	R900894987
200	R900894974	R900894988
220	R900894975	R900894989
250	R900894976	R900894991
280	R900894977	R900894993
320	R900894978	R900894994

ØAL = Piston Ø

ØMM = Piston rod Ø

²⁾ Seal kits for position measurement system separate material no.

Tightening torques

Screws: Head and base (item 1 and 2)

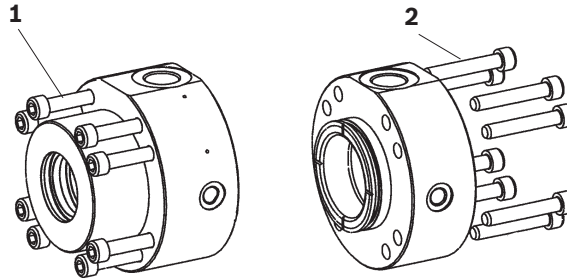

Series	Piston Ø	Screw	Quantity	Quality class	Tightening torque
CDH2...XC / CGH2...XC / CSH2...XE	40	M8	4	10.9	23 Nm
CDH2...XC / CGH2...XC / CSH2...XE	50	M8	8	10.9	20 Nm
CDH2...XC / CGH2...XC / CSH2...XE	63	M8	8	10.9	30 Nm
CDH2...XC / CGH2...XC / CSH2...XE	80	M10	8	10.9	55 Nm
CDH2...XC / CGH2...XC / CSH2...XE	100	M12	8	10.9	100 Nm
CDH2...XC / CGH2...XC / CSH2...XE	125	M16	8	10.9	200 Nm
CDH2...XC / CGH2...XC / CSH2...XE	140	M16	12	10.9	170 Nm
CDH2...XC / CGH2...XC / CSH2...XE	160	M16	12	10.9	220 Nm
CDH2...XC / CGH2...XC / CSH2...XE	180	M20	12	10.9	350 Nm
CDH2...XC / CGH2...XC / CSH2...XE	200	M20	12	10.9	410 Nm
CDH2...XC / CGH2...XC / CSH2...XE	220	M20	16	10.9	460 Nm
CDH2...XC / CGH2...XC / CSH2...XE	250	M24	16	10.9	700 Nm
CDH2...XC / CGH2...XC / CSH2...XE	280	M30	12	10.9	1700 Nm
CDH2...XC / CGH2...XC / CSH2...XE	320	M30	16	10.9	1500 Nm

Screws: Seal cover (item 3)

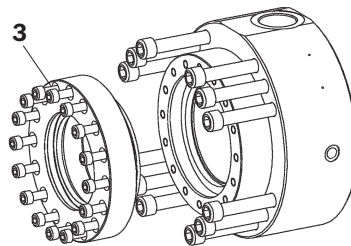

Only with seal design "A" and "B"

Series	Piston Ø	Piston rod Ø	Screw	Quantity	Quality class	Tightening torque
CDH2...XC / CGH2...XC	160	100	M10	16	10.9	60 Nm
		110				
CDH2...XC / CGH2...XC	180	110	M12	16	10.9	80 Nm
		125				
CDH2...XC / CGH2...XC	200	125	M12	16	10.9	90 Nm
		140				
CDH2...XC / CGH2...XC	220	140	M12	16	10.9	90 Nm
		160		24		
CDH2...XC / CGH2...XC	250	160	M12	24	10.9	90 Nm
		180				
CDH2...XC / CGH2...XC	280	180	M12	24	10.9	90 Nm
		200				
CDH2...XC / CGH2...XC	320	200	M12	24	10.9	90 Nm
		220	M16	16		230 Nm

Spare parts drawing: Series CDH2...XC:

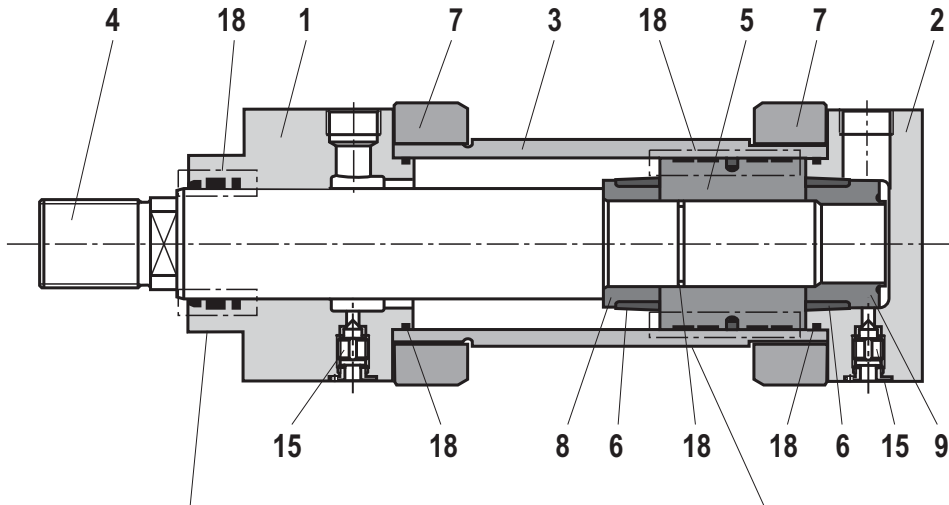

Piston rod

"M"

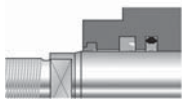

"S / T"

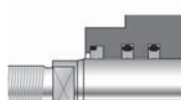

"A / B"

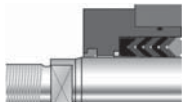

Piston

"M / T / S"

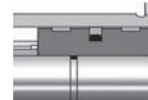

"A / B"

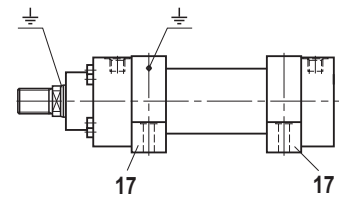
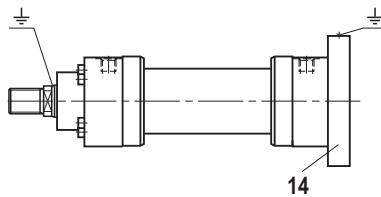
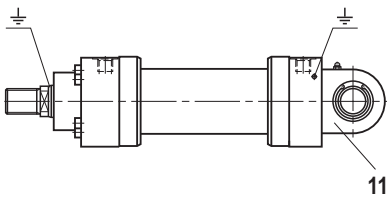
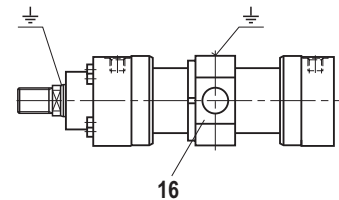
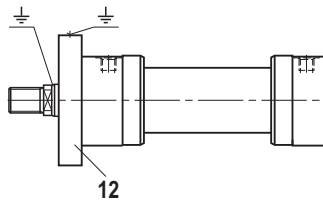
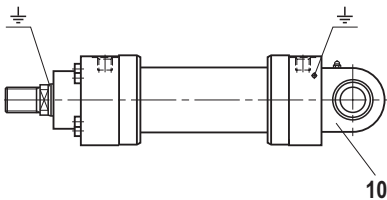
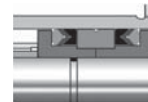

- | | | | |
|--------------|----------------|---------------------|---------------|
| 1 Head | 6 Damping bush | 11 Base MP5 | 17 Foot MS2 |
| 2 Base | 7 Flange | 12 Round flange MF3 | 18 Seal kit: |
| 3 Pipe | 8 Socket | 14 Round flange MF4 | ▶ Wiper |
| 4 Piston rod | 9 Socket | 15 Bleeding | ▶ Rod seal |
| 5 Piston | 10 Base MP3 | 16 Trunnion MT4 | ▶ Piston seal |
| | | | ▶ Seal ring |
| | | | ▶ Guide ring |

Spare parts drawing: Series CGH2...XC:

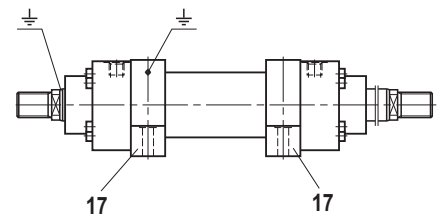
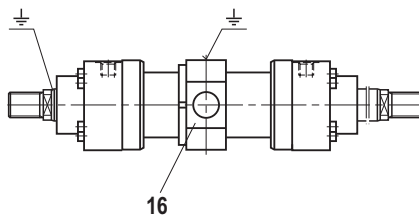
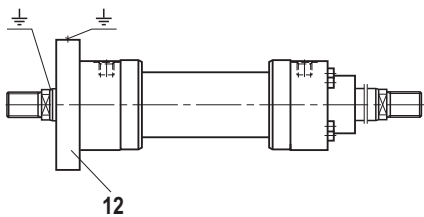
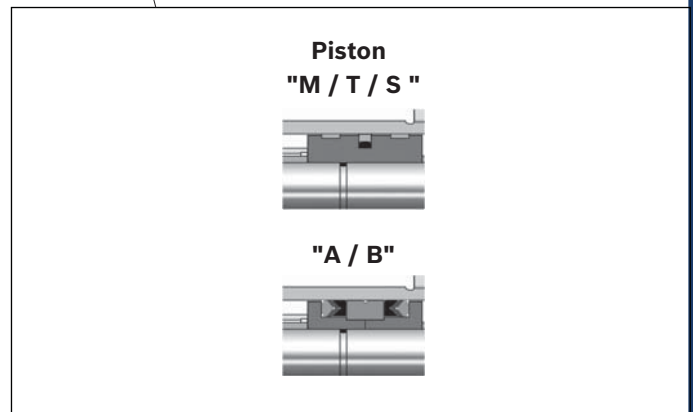
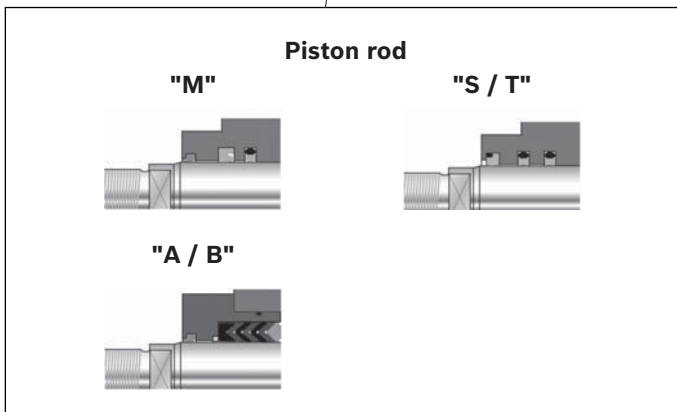
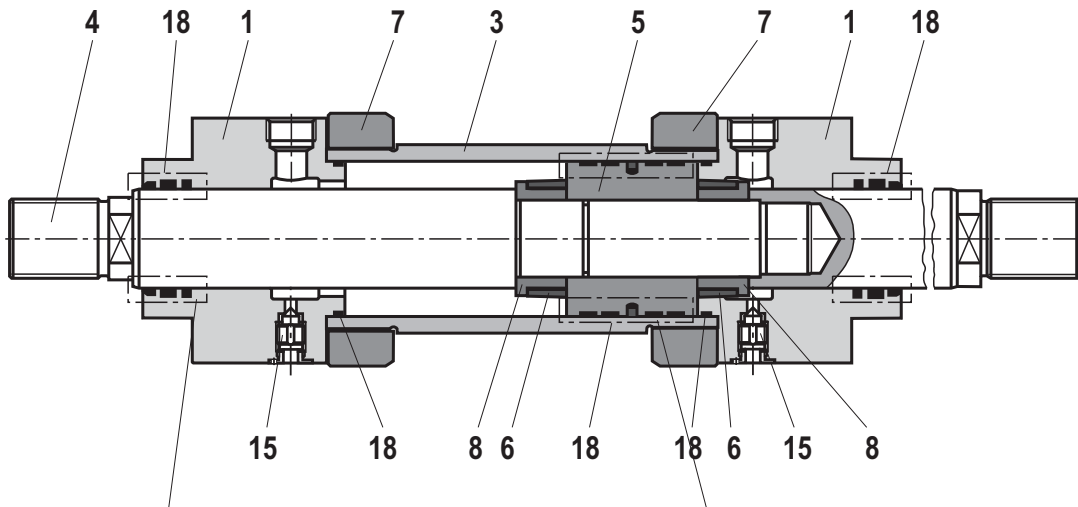

- 1 Head
- 3 Pipe
- 4 Piston rod
- 5 Piston
- 6 Damping bush
- 7 Flange

- 8 Socket
- 12 Round flange MF3
- 15 Bleeding
- 16 Trunnion MT4
- 17 Foot MS2

- 18 Seal kit:**
- ▶ Wiper
 - ▶ Rod seal
 - ▶ Piston seal
 - ▶ Seal ring
 - ▶ Guide ring

Spare parts drawing: Series CSH2...XE: MF3, MF4, MT4 and MS2

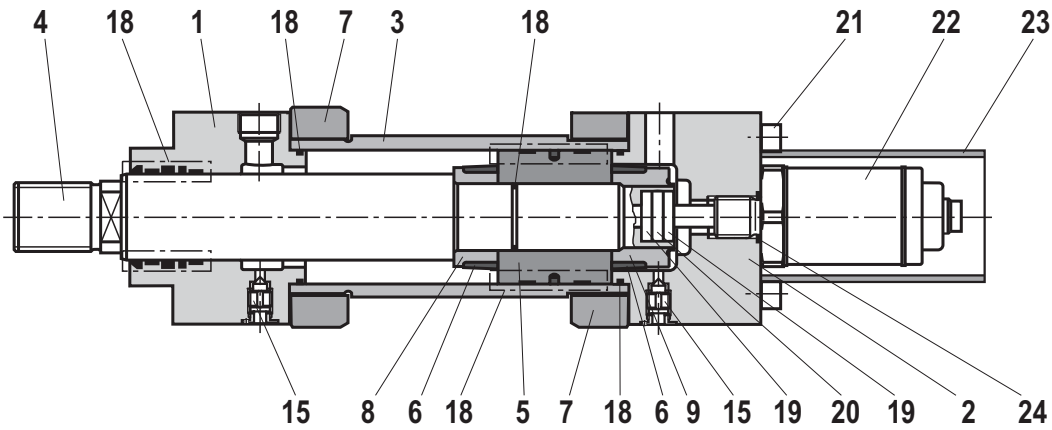

Piston rod
"M" "S / T"



Piston
"M / T / S"

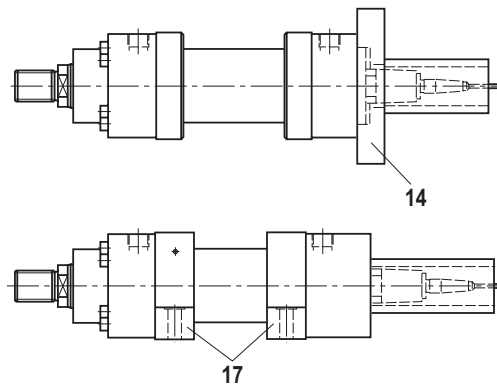
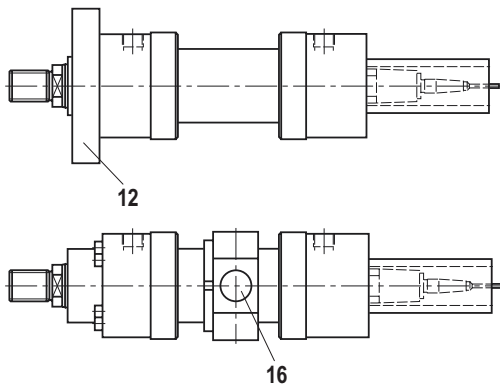
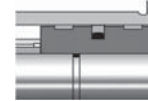

- | | | | |
|----------------|---------------------|-----------------|-----------------------------------|
| 1 Head | 7 Flange | 16 Trunnion MT4 | 19 Insulating socket |
| 2 Base | 8 Socket | 17 Foot MS2 | 20 Solenoid |
| 3 Pipe | 9 Socket | 18 Seal kit: | 21 Hexagon socket head cap screws |
| 4 Piston rod | 12 Round flange MF3 | ▶ Wiper | 22 Position transducer |
| 5 Piston | 14 Round flange MF4 | ▶ Rod seal | 23 Protective pipe |
| 6 Damping bush | 15 Bleeding | ▶ Piston seal | 24 Seal |
| | | ▶ Seal ring | |
| | | ▶ Guide ring | |

Spare parts drawing: Series CSH2...XE: MP3 and MP5

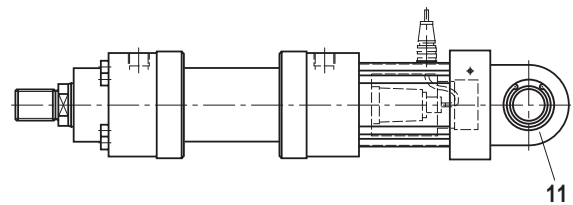
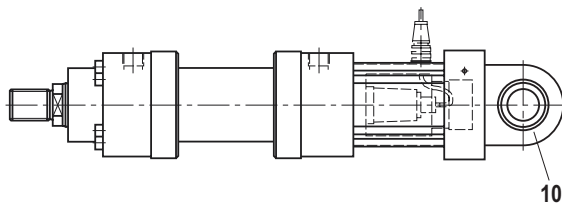
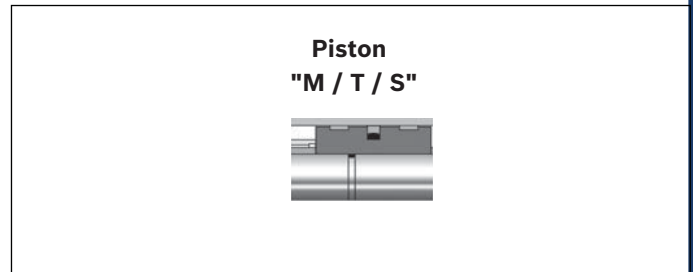
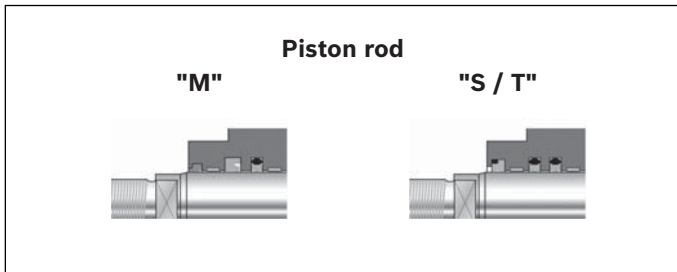
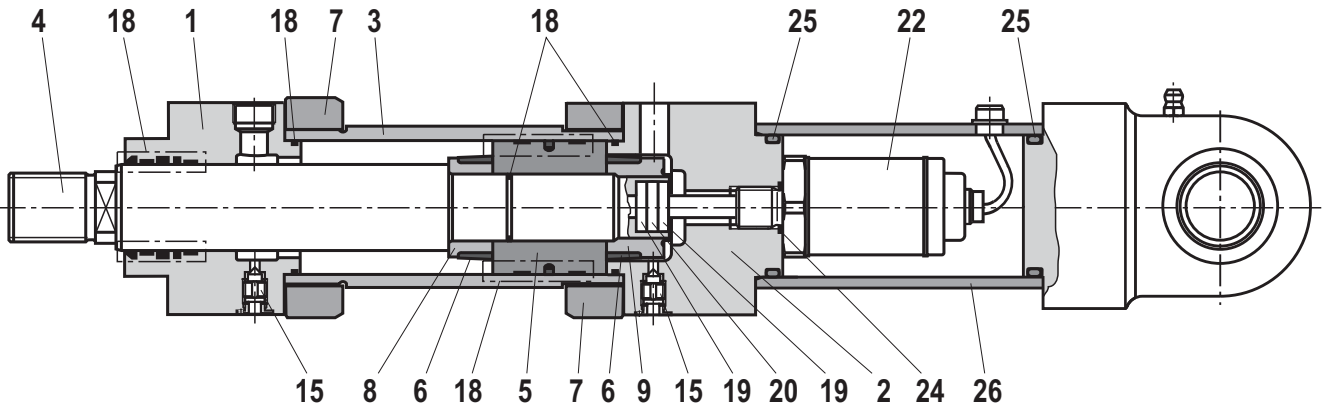

- | | | | |
|----------------|-------------|---------------|------------------------|
| 1 Head | 7 Flange | 18 Seal kit: | 19 Insulating socket |
| 2 Base | 8 Socket | ▶ Wiper | 20 Solenoid |
| 3 Pipe | 9 Socket | ▶ Rod seal | 22 Position transducer |
| 4 Piston rod | 10 Base MP3 | ▶ Piston seal | 24 Seal |
| 5 Piston | 11 Base MP5 | ▶ Seal ring | 25 Seal |
| 6 Damping bush | 15 Bleeding | ▶ Guide ring | 26 Protective pipe |

Cylinder weight

Piston ØAL mm	Piston rod ØMM mm	CD/CS cylinder with 0 mm stroke length					Per 100 mm stroke length kg	CG cylinder with 0 mm stroke length			Per 100 mm stroke length kg
		MP3 ¹⁾ MP5 ¹⁾ kg	MP3 ²⁾ MP5 ²⁾ kg	MF3 MF4 kg	MT4 kg	MS2 kg		MF3 kg	MT4 kg	MS2 kg	
40	25	7	12	9	9	9	0.9	10	10	10	1.3
	28	7	12	9	9	9	1.0	10	10	10	1.5
50	32	12	19.5	14	13	13	1.3	16	16	16	1.9
	36	12	19.5	14	13	14	1.5	16	16	16	2.3
63	40	20	29.5	21	21	21	2.3	25	25	25	3.3
	45	20	29.5	21	21	21	2.6	25	25	25	3.8
80	50	32	42.5	35	34	35	3.2	41	40	41	4.7
	56	32	42.5	35	34	36	3.6	41	40	42	5.5
100	63	51	64.5	54	54	55	5.2	63	63	64	7.6
	70	51	64.5	55	54	56	5.7	64	64	65	8.8
125	80	95	114	96	99	98	8.2	113	115	114	12.1
	90	96	115	97	100	99	9.2	115	117	116	14.2
140	90	131	157	132	136	137	10.7	155	158	159	15.7
	100	132	158	133	137	138	11.9	156	160	161	18.1
160	100	185	220	184	197	206	12.6	217	231	239	18.8
	110	186	221	186	199	207	13.9	220	233	242	21.4
180	110	255	303	253	264	274	14.7	294	305	314	22.1
	125	258	304	256	267	277	16.8	300	311	320	26.5
200	125	349	405	332	350	363	19.0	359	377	389	28.6
	140	352	406	335	353	366	21.5	365	383	396	33.5
220	140						27.1				39.1
	160	527	625	512	546	518	30.9	604	638	610	46.7
250	160						32.7				48.5
	180	673	795	640	677	650	36.9	761	798	772	56.9
280	180						44.2				64.2
	200	976	1192	966	1020	918	48.8	1130	1183	1081	73.4
320	200						55.2				79.8
	220	1251	1512	1172	1223	1174	60.4	1354	1405	1356	90.2

ØAL = Piston Ø

ØMM = Piston rod Ø

¹⁾ Weight without position measurement system

²⁾ Weight with position measurement system

EC Declaration of Conformity

Wir erklären, dass das Produkt mit den Bestimmungen der Richtlinie 94/9/EG Explosionsschutz übereinstimmt.

Produktbezeichnung: Hydrozylinder für explosionsgefährdete Bereiche

Baureihe: CDH2...XC/...
CGH2...XC/...
CSH2...XE/...

Angewendete harmonisierte Normen: EN 1127-1, EN 13 463-1, EN 13 463-5

Hersteller: BOSCH REXROTH AG
Zum Eisengießer 1
97816 Lohr am Main
Deutschland

Lohr am Main
Ort

Oktober 2013
Datum



Franz Wirzberger
Leiter Entwicklung
Hydraulikzylinder



Holger Gast
Technischer Leiter
Hydraulikzylinder