

Electric Drives
and Controls

Hydraulics

Linear Motion and
Assembly Technologies

Pneumatics

Service

Rexroth
Bosch Group

3/3 directional high-response valve (cartridge valve) with integrated control electronics

RE 29222/02.09
Replaces: 29218

1/14

Type 3WRCBEE

Sizes 25, 32 and 50
Component series 1X
Maximum operating pressure 315 bar
Maximum flow 2,250 l/min



Table of contents

Contents	Pages
Features	1
Ordering code, symbols	2
Function, section	3
Technical data	4
Electrical connection	5
Integral control electronics (OBE)	6 and 7
Characteristic curves	8 to 10
Unit dimensions	11 to 13
Installation dimensions	14

Features

- Pilot operated 3/3 directional high-response valve sizes 25, 32 and 50
- Design: Block installation, 3/3 directional symbol control edges P > A or A > T
- Mounting cavity, see page 14
- Control spool with anti-rotation feature and control edges in servo-performance quality
- Pressure-resistant up to 315 bar
- With inductive position transducer on main spool and pilot valve
- Position-controlled with integrated electronics OBE.
- These valves serve for closed-loop control of the magnitude and direction of the flow.
- Completely adjusted unit
- Flow characteristics
 - M = Progressive with fine control edge
- In case of an error in the OBE and pilot pressure applied the main spool is opened in direction A towards T. P to A is blocked then.

Ordering code

3WRCB	EE							M	-1X	/G24	K31	/	M	*
--------------	-----------	--	--	--	--	--	--	----------	------------	-------------	------------	----------	----------	----------

3/3 high-response cartridge valve															Further details in the clear text
Integrated pilot and OBE															M = NBR seals suitable for mineral oils (HL, HLP) according to DIN 51524 ²⁾
Size 25															Electronics interface
Size 32															A1 = ±10 V DC
Size 50															F1 = 4 to 20 mA
Spool with zero overlap															Electrical connection
Actuating area ratio at the spool ¹⁾															K31 = Without mating connector, individual connection with connector according to DIN EN 175201-804
1:1 (Size 50)															G24 = Voltage supply OBE 24V
1:1.5 (Size 25, size 32)															1X = Component series 10 to 19 (10 to 19: unchanged mounting and connection dimensions)
Nominal flow l/min (at 5 bar valve pressure drop)															
Size 25															
190 l/min															= 190
Size 32															
380 l/min															= 380
Size 50															
750 l/min															= 750
Characteristic curve inflected															= M
Progressive with linear fine control range															

¹⁾ Determined in the factory
²⁾ Other seal materials upon request

Symbols

Simplified

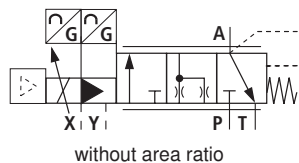
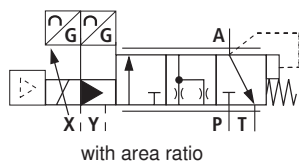

Detailed

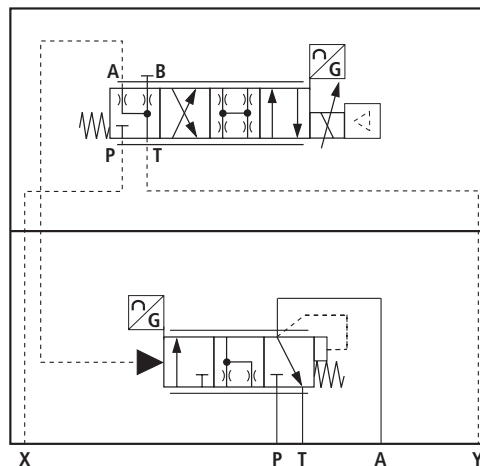

Pilot valve
4WRPEH6

Main stage
In preferred position with de-energized pilot valve (example with area ratio)

Function, section

The 3/3 directional high-response valve is designed as cartridge valve with integrated control electronics for the stepless closed-loop control of a flow from P to A and A to T.

Technical design

The valve consists of the following assemblies

- Cover (1) with connection faces,
- Main spool (7) with control edges,
- Bushing (2),
- Pilot control valve (3) with paired spool/bushing unit and inductive position transducer (6).
- Integrated control electronics (4) with inductive position transducer (12) of the main spool.

Function

- Actuation of the main spool (7) using the pilot control valve (3); pressure build-up in the control chamber (10) acts on area (8) – the pressure in port A acting on area (11) and the spring force (9) act in the opposite direction
- The spool of the pilot control valve is controlled by means of proportional solenoid (5) against the force of the spring in the pilot control valve.
- Linking of command values (4) and actual values (12 and 6) in the microcontroller of the integrated control electronics (4)
- Pilot oil supply X to the pilot control valve port P; pilot oil drain via Y to the tank
- At command value 0 V or 12 mA the electronics controls the main spool (7) in central position, thus pressure in A approx. P system/2
- Area ratio of area (11) to area (8) at:
Size 25 = 1 : 1.5
Size 32 = 1 : 1.5
Size 50 = 1 : 1

Failure of supply voltage

- The integrated control electronics de-energizes the solenoid when the supply voltage fails or the cable is ruptured
- Depressurization of spool area (8) via pilot control valve (3) to Y to the tank.
- Due to spring force (9) and pressure in port A on area (11) the main spool (7) opens the connection A to T and closes from P to A

Important note:

Failure of the supply voltage results in the closed control loop stopping abruptly. The accelerations occurring at this point may lead to machine damages.

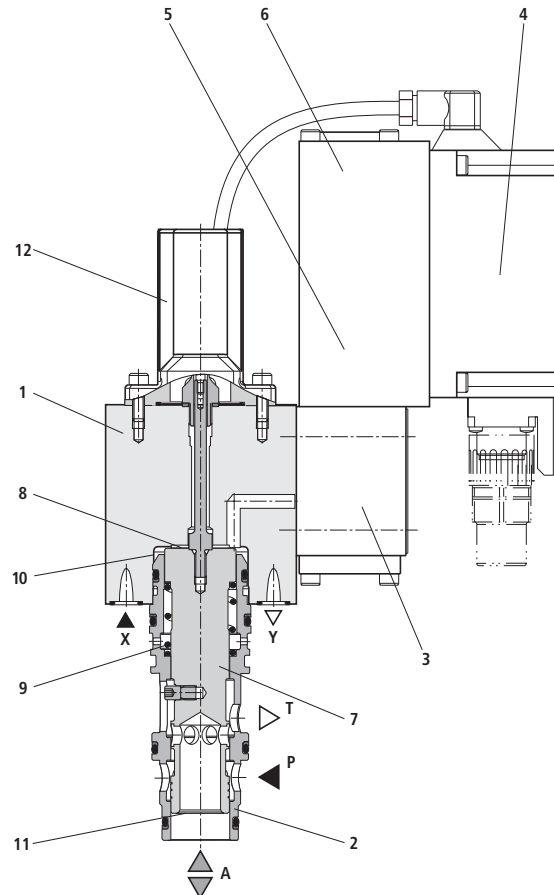

Section example size 25

Technical data (For applications outside these parameters, please consult us!)

general

Size		25	32	50
Weight	kg	11.8	16.2	23.2
Installation position		Any (when the valve is installed on a consumer, you should avoid the main spool being arranged parallel to the acceleration respectively deceleration direction of the consumer!)		
Ambient temperature range	°C	-20 to +50		
Storage temperature range	°C	-20 to +80		

hydraulic

Max. operating pressure	bar	up to 315		
Return flow pressure	bar	up to 30		
Nominal flow $q_{V \text{ nom}}$ at $\Delta p = 5 \text{ bar}$	l/min	190	380	750
Max. admissible flow	l/min	600	1,000	2,250
Max. zero flow in control position (at $p = 315 \text{ bar}$)	l/min	1.5	2.5	3.5
Pilot flow in X or Y for minimum actuating time (command value -100% to +100%)	l/min	12	16	30
Leakage in spring-centered position (-100% command value) at max. operating pressure	l/min	0.2	0.4	0.8
Area ratio of main spool		1 : 1.5	1 : 1.5	1 : 1
Main spool spring		$\Delta p = 2.5 \text{ bar}$ (relating to the spool area at port A)		
Hydraulic fluid		Mineral oil (HL, HLP) according to DIN 51 524		
Hydraulic fluid temperature range	°C	-20 to +80		
Viscosity range	mm ² /s	15 to 380		
Cleanliness class accord- ing to ISO code	Pilot valve	Maximum admissible degree of contamination of the hydraulic fluid according to ISO 4406 (c) ¹⁾ class 18/16/13		
	Main valve	Maximum admissible degree of contamination of the hydraulic fluid according to ISO 4406 (c) ¹⁾ class 18/20/15		
Hysteresis	%	< 0.1		
Response sensitivity	%	< 0.1		

electrical

Supply voltage DC	Nominal voltage	V	24	
	Lower limit value	V	21	
	Upper limit value	V	35	
Current consumption	I_{max}	A	1.8	
	Impulse load	A	3	
Duty cycle	%	100		
Protection class according to DIN 40050		IP 65 with mating connector mounted and locked		
Thermal drift of the main spool	%/10K	0.16	0.34	0.02
Control electronics		Integrated in the valve, see pages 6 and 7		

¹⁾ The cleanliness classes specified for the components must be adhered to in hydraulic systems. Efficient filtration prevents malfunctions and at the same time prolongs the service life of components.
For the selection of filters, see data sheets RE 50070, RE 50076, and RE 50081.

Electrical connection

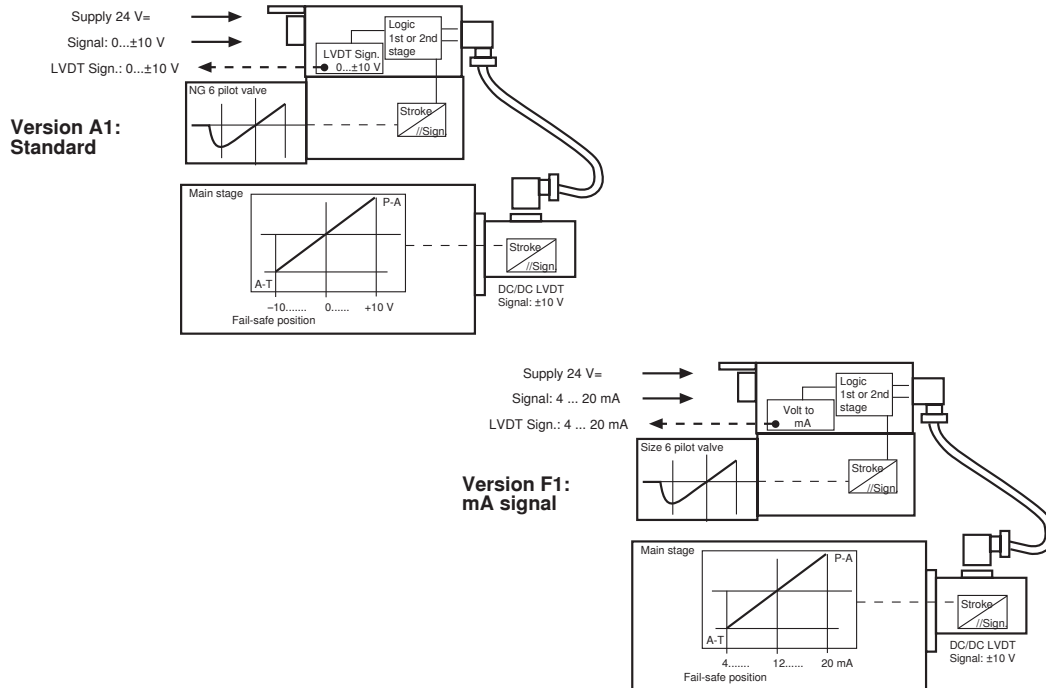

Mating connector 6P+PE / PG11 according to DIN EN 175201-804

See data sheet RE 08008

Separate order with material no. 1834484252

Pinout, see pages 6 and 7

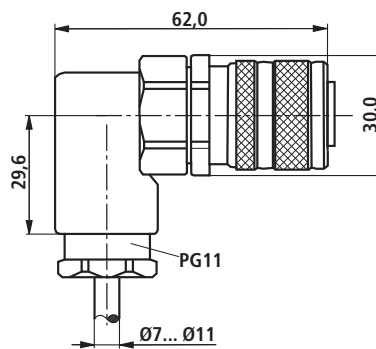

Integral control electronics

Block circuit diagram / pinout

Version A1: $U_{D,E} \pm 10\text{ V}$

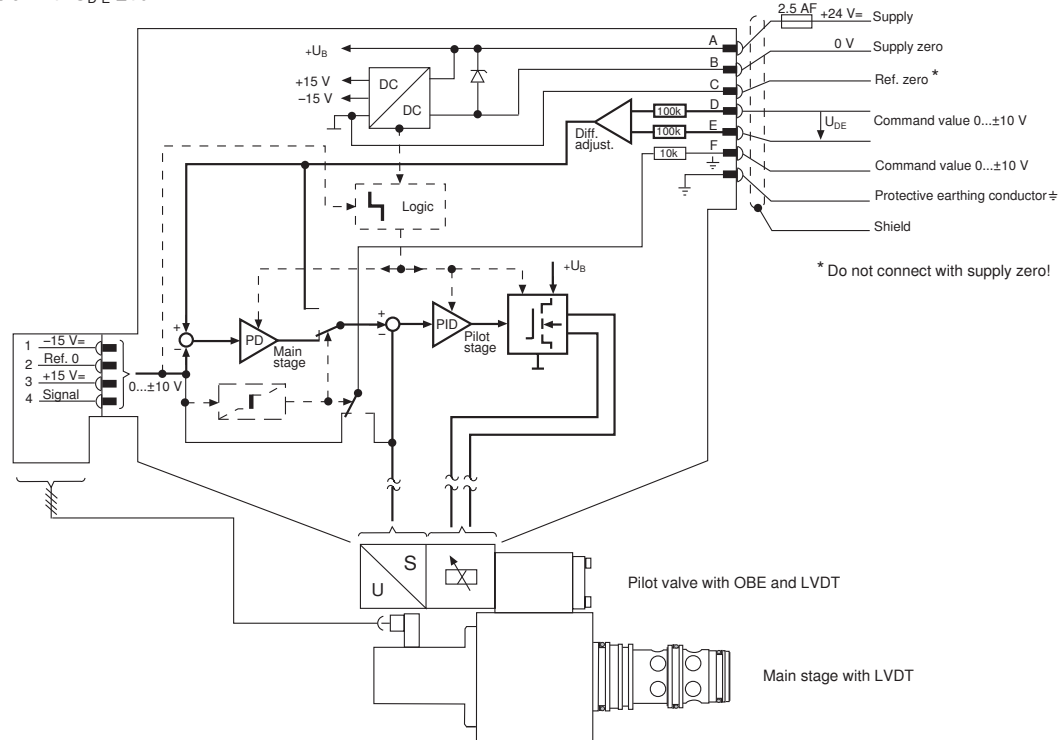

* Do not connect with supply zero!

Pinout 6P+PE

Version A1: $U_{D,E} \pm 10\text{ V}$

($R_i = 100\text{ k}\Omega$)

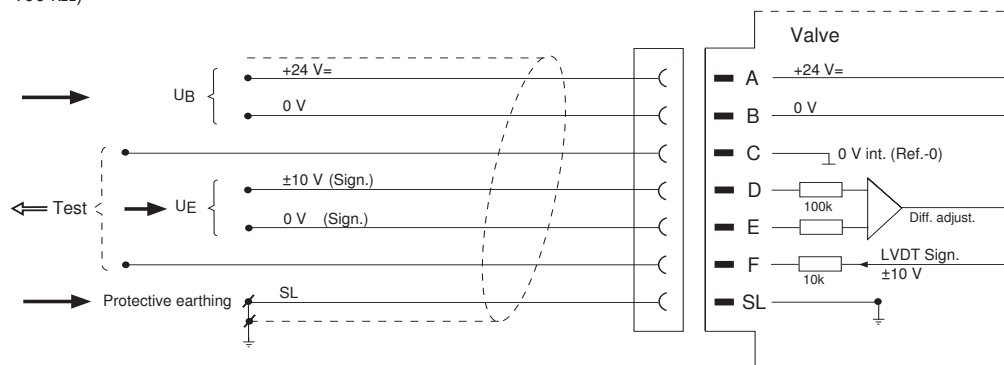

Recommendation connecting cable: - up to 25 m min 0.75 mm² per wire
- up to 50 m min 1.5 mm² per wire
- with shield braid (connect shield to supply zero of the mains adapter on one side)
- max. external diameter 7 to 11 mm

Integral control electronics

Block circuit diagram / pinout

Version F1: I_{D-E} 4...12...20 mA

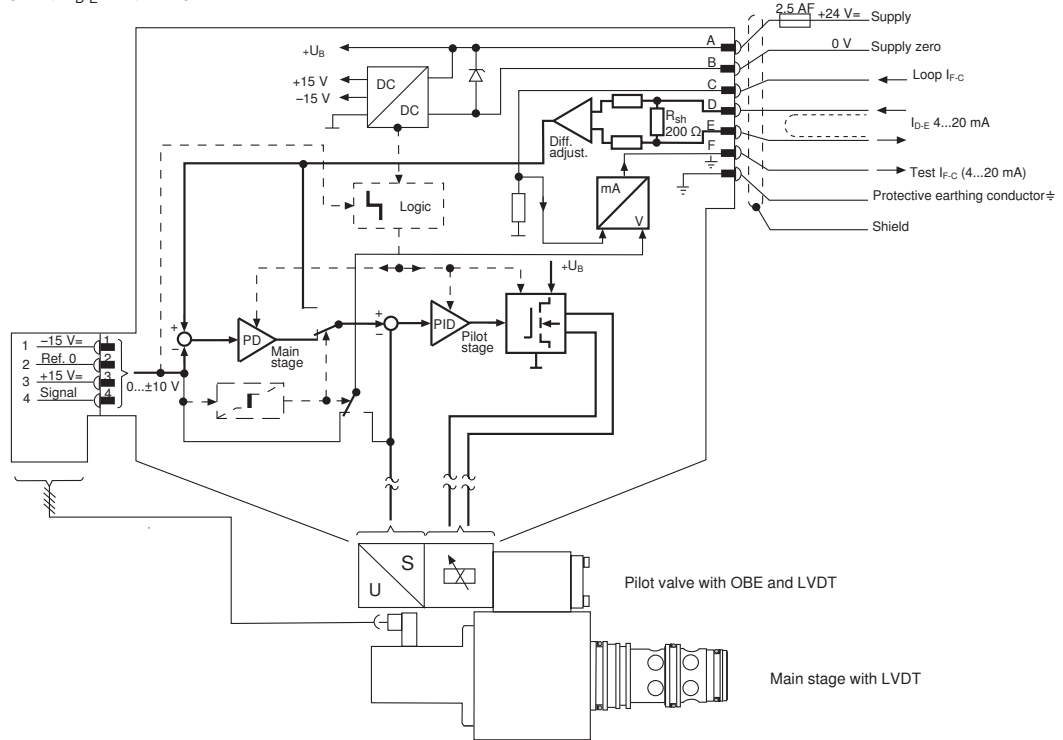

Pinout 6P+PE

Version F1: I_{D-E} 4...12...20 mA

($R_{sh} = 200 \Omega$)

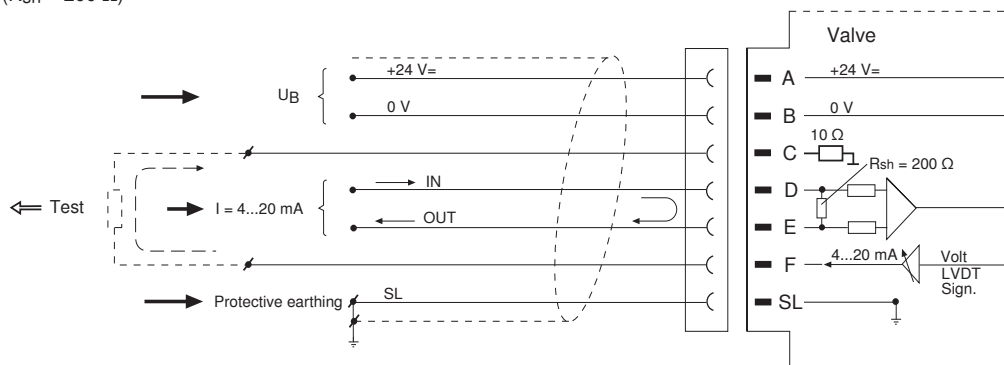

- Recommendation connecting cable:
- up to 25 m min 0.75 mm² per wire
 - up to 50 m min 1.5 mm² per wire
 - with shield braid (connect shield to supply zero of the mains adapter on one side)
 - max. external diameter 7 to 11 mm

Characteristic curves size 25 (measured with HLP32, $\vartheta_{oil} = 40^\circ\text{C} \pm 5^\circ\text{C}$)

Nominal flow for $Q_N = 190\text{ l/min}$ at $D_p 5\text{ bar}$

Pressure/signal function

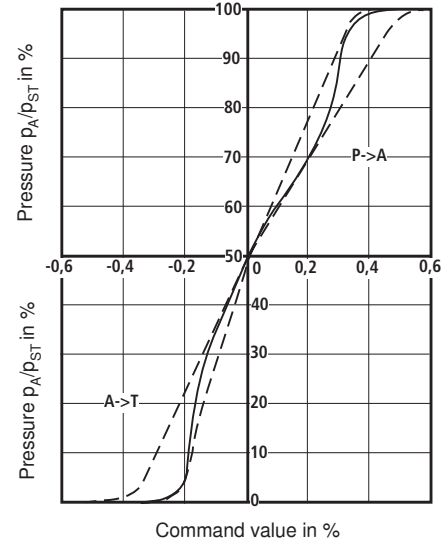
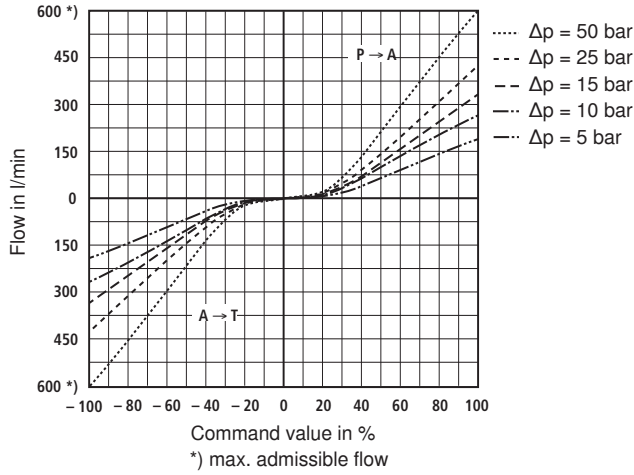

Frequency response at $p_{St}/p_A = 100\text{ bar}/50\text{ bar}$

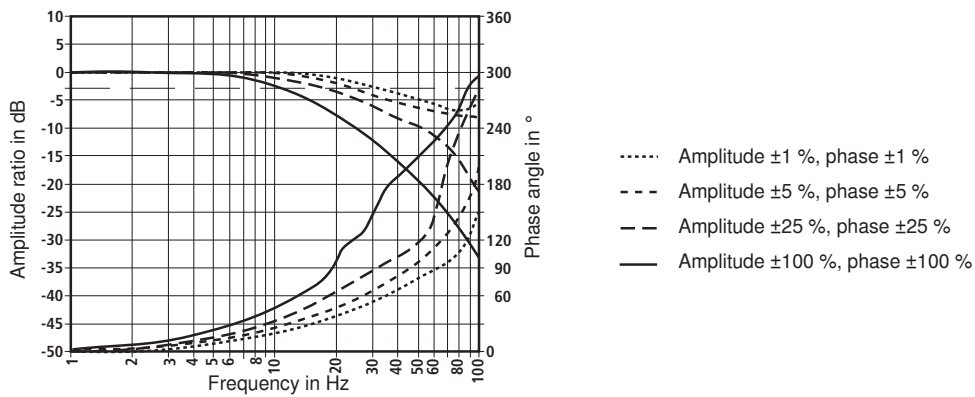

Dependency of the frequency response at -90° and $p_{St}/p_A = 100\text{ bar}/50\text{ bar}$

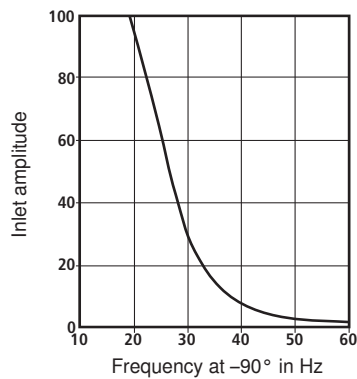

Transition function with stepped, electrical input signal measured at $p_{St}/p_A = 100\text{ bar}/50\text{ bar}$

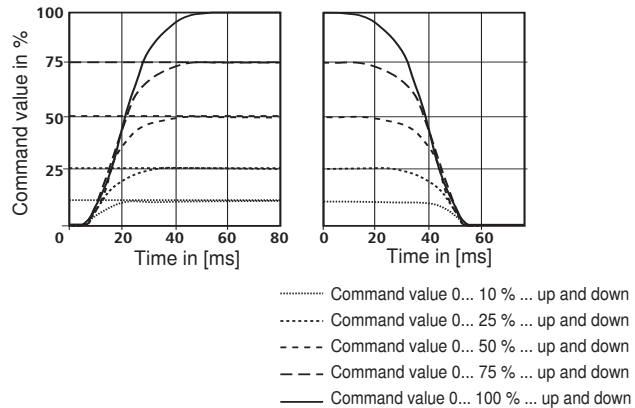

Characteristic curves size 32 (measured with HLP32, $\vartheta_{oil} = 40^\circ\text{C} \pm 5^\circ\text{C}$)

Nominal flow for $Q_N = 380$ l/min at D_p 5 bar

Pressure/signal function

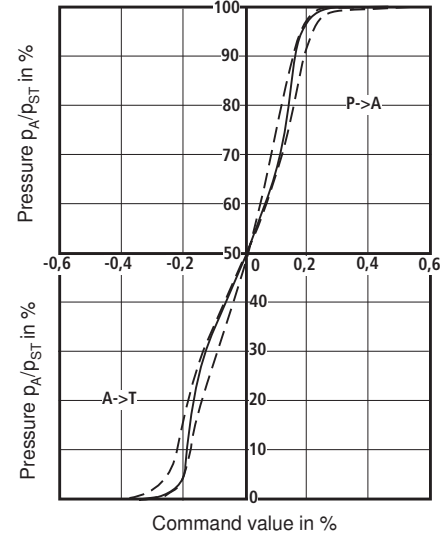
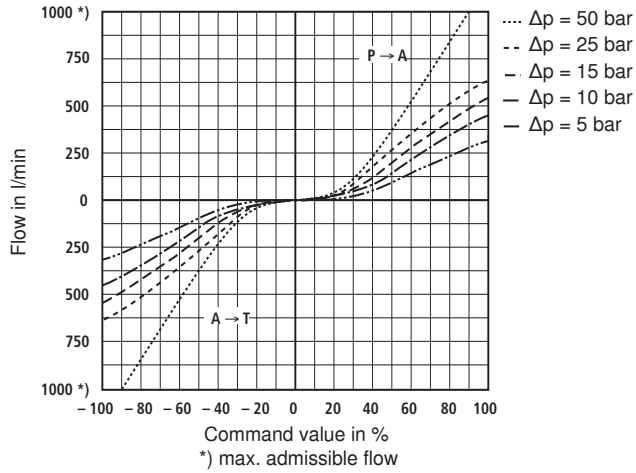

Frequency response at $p_{St}/p_A = 100$ bar/50 bar

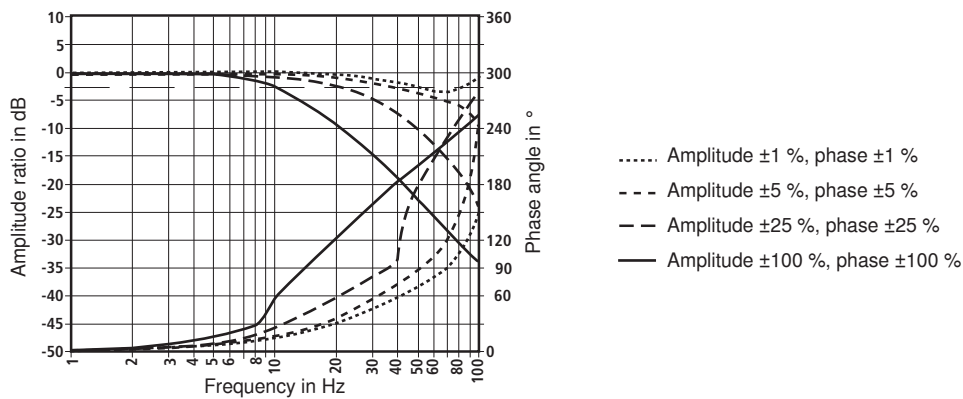

Dependency of the frequency response at -90° and $p_{St}/p_A = 100$ bar/50 bar

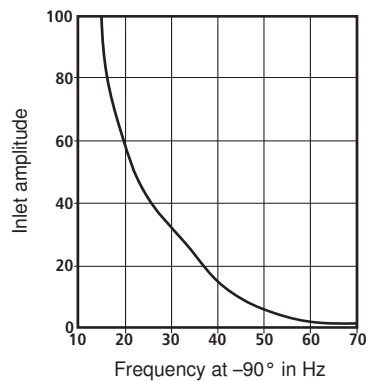

Transition function with stepped, electrical input signal measured at $p_{St}/p_A = 100$ bar/50 bar

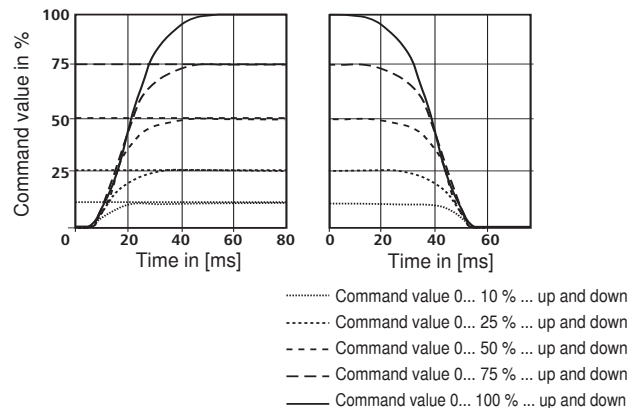

Characteristic curves size 50 (measured with HLP32, $\bar{\theta}_{oil} = 40^\circ\text{C} \pm 5^\circ\text{C}$)

Nominal flow for $Q_N = 750\text{ l/min}$ at $D_p = 5\text{ bar}$

Pressure/signal function

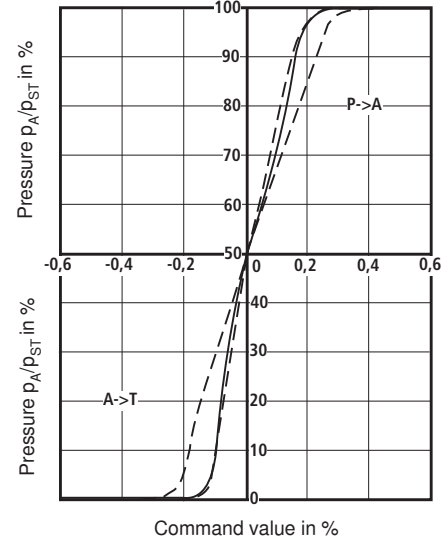
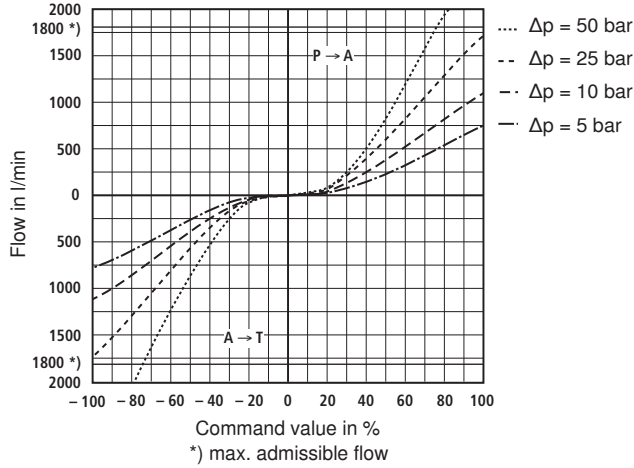

Frequency response at $p_{St}/p_A = 100\text{ bar}/50\text{ bar}$

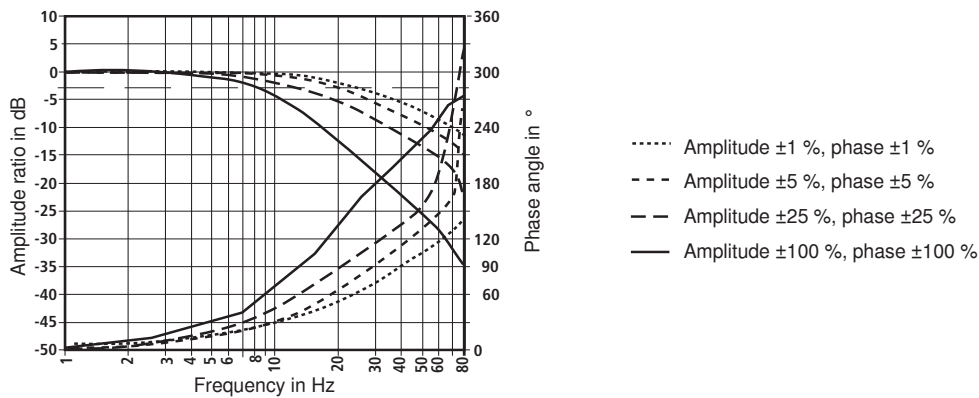

Dependency of the frequency response at -90° and $p_{St}/p_A = 100\text{ bar}/50\text{ bar}$

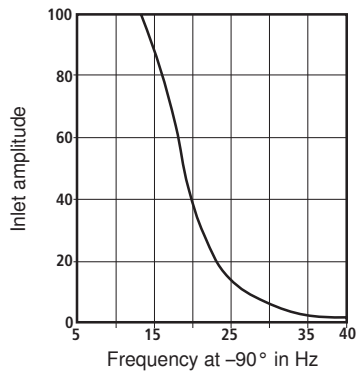

Transition function with stepped, electrical input signal measured at $p_{St}/p_A = 100\text{ bar}/50\text{ bar}$

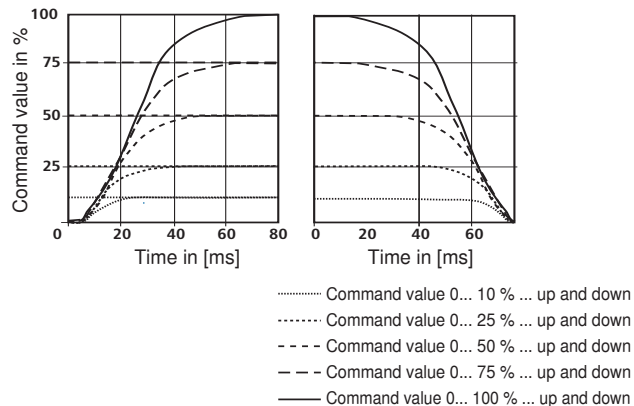

Unit dimensions: Size 25 (dimensions in mm)

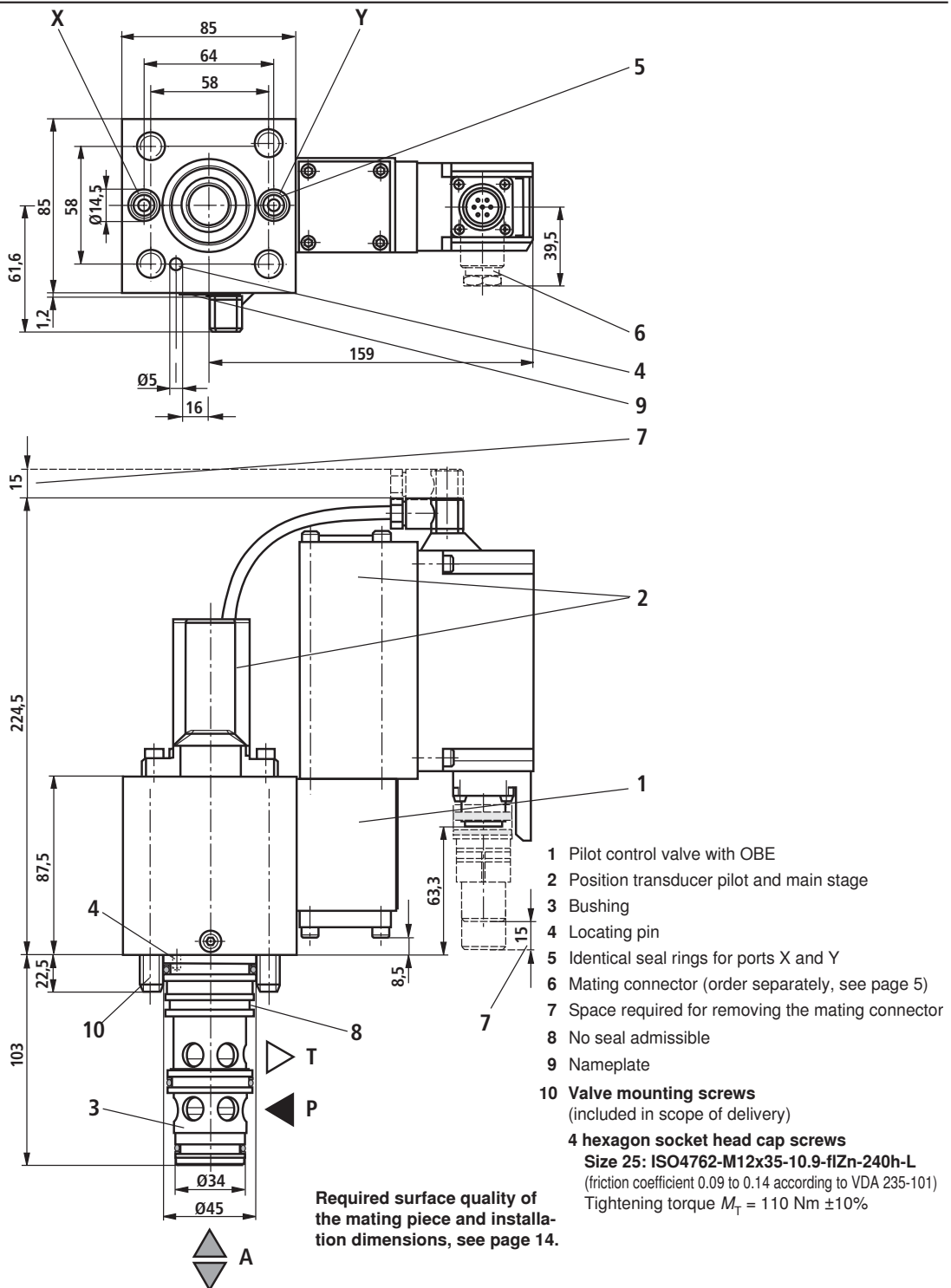

Unit dimensions: Size 32 (dimensions in mm)

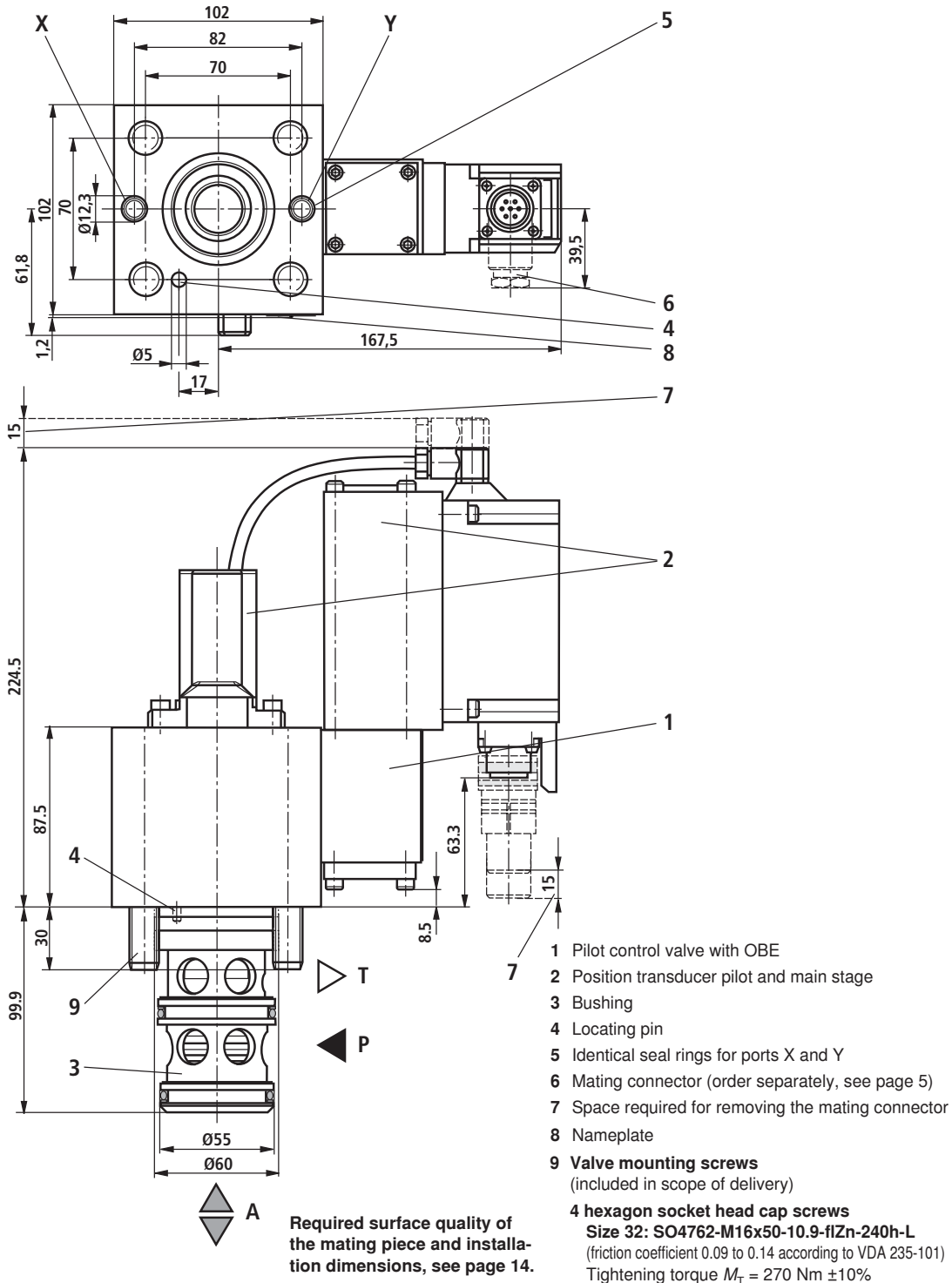

Unit dimensions: Size 50 (dimensions in mm)

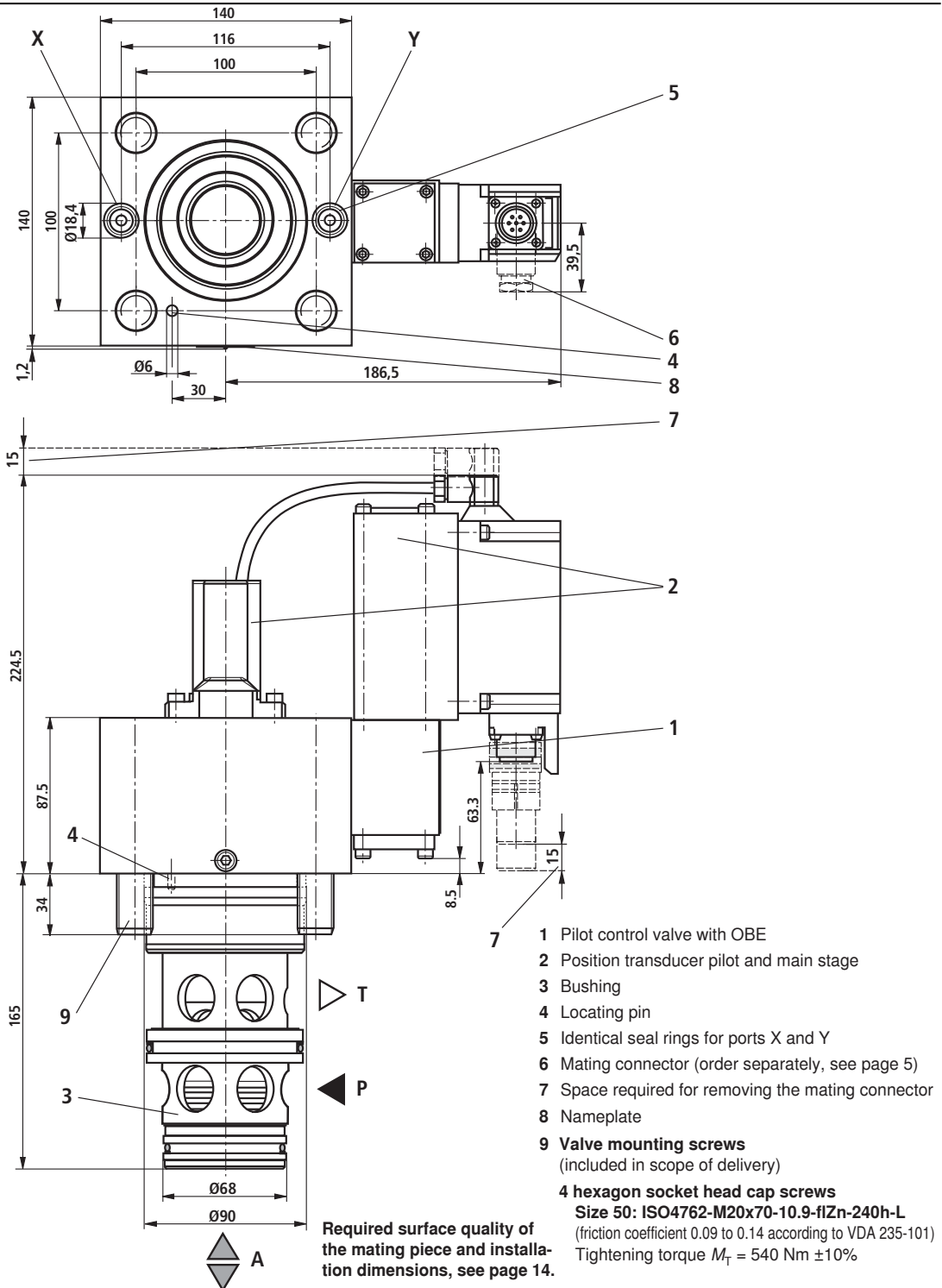

Mounting cavity (dimensions in mm)

Size	25	32	50
L1	85	102	140
L2	85	102	140
L3	42,5	51	70
L4±0.2	58	70	100
L5±0.1	29	35	50
L6±0.2	33	41	58
L7±0.2	16	17	30
H1 ^{+0.1}	103	100	165
H2	56	43.5	87
H3	45	30	66
H4	15	16	40
H5	25	18	66
H6±0.3	78	70.5	122
H7 ^{+0.3}	89	85	143
H8	11.5	13.5	18
H9	2.5	3	3
H10	2.5	2.5	4
ØD1H7 [Ⓔ]	45	60	90
ØD2H7 [Ⓔ]	43	58	87
ØD3H7 [Ⓔ]	34	55	68
max. ØD4	20	30	35
max. ØD5	20	24	35
max. ØD6	6	8	10
D7	M12	M16	M20
ØD8H13	6	6	8
ØD9 ^{+0.2}	33.7	54.7	67.7
T1	25	35	45
min T2	10	10	10
V	0.03	0.03	0.03
W	0.05	0.1	0.1

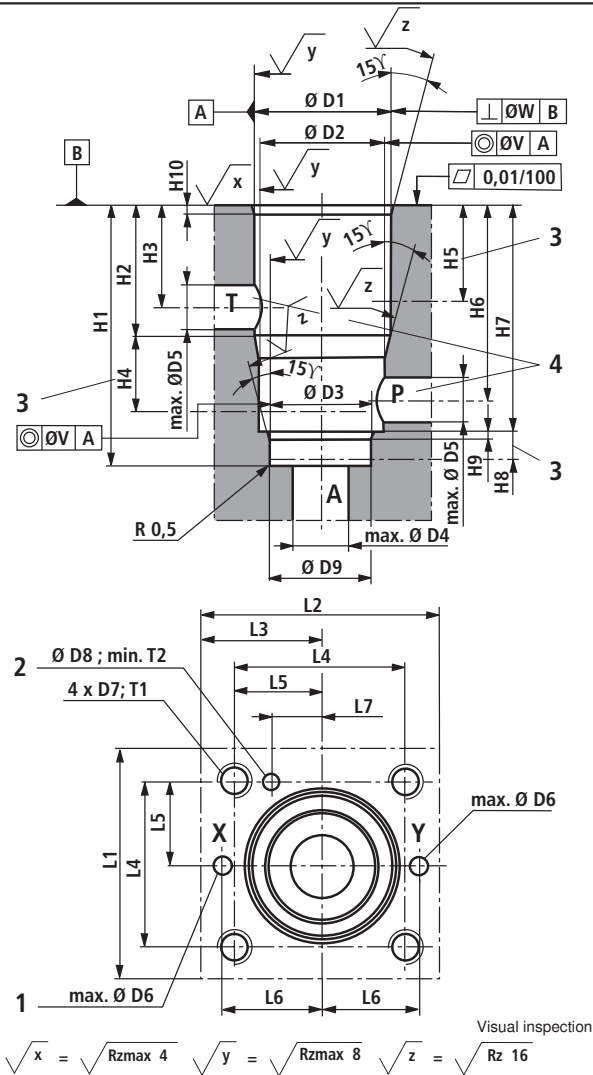

Tolerance ISO 8015
General tolerances ISO 2768-mK

- 1 Connect port X with port P or externally
- 2 Boring for locating pin
- 3 Depth of fit
- 4 Ports P and T can be positioned around the central axis of port A. Mounting and pilot bores must not be damaged in doing so.

RE 29222/02.09 | 3WRCBEE

Hydraulics | Bosch Rexroth AG

Notes

© This document, as well as the data, specifications and other information set forth in it, are the exclusive property of Bosch Rexroth AG. It may not be reproduced or given to third parties without its consent. The data specified above only serve to describe the product. No statements concerning a certain condition or suitability for a certain application can be derived from our information. The information given does not release the user from the obligation of own judgment and verification. It must be remembered that our products are subject to a natural process of wear and aging.