

Wedge clamp, double-acting, type A for dies with flat clamping edge

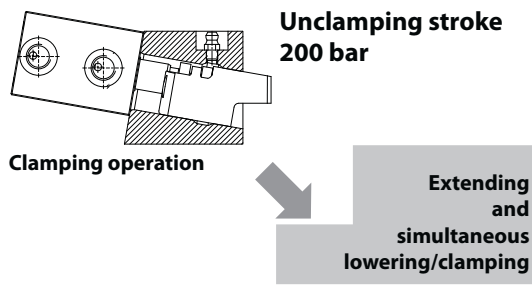

ROEMHELD
HILMA ■ STARK

Type A - Clamping force axially applied to the clamping edge

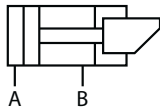

Application:

- safe clamping of dies with flat clamping edge
- for clamping of dies in injection moulding machines
- for clamping of dies on press bed and slide

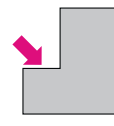

Design:

Double-acting wedge clamp for clamping dies on the press bed or slide or for clamping dies in injection moulding machines according to Euromap standard.

The wedge clamp consists of a hydraulic block cylinder connected with a clamping bolt in a floating manner. Clamping cycle: the clamping bolt which is inclined by 5° performs an idle stroke and simultaneously a clamping stroke. The clamping bolt is lowered axially onto the clamping edge. The 5° angle of the housing has been determined so as to ensure that despite frictional engagement on the clamping edge the hydraulic pressure required for unclamping is sufficient.

Since the clamping force is vertically transmitted to the clamping point, only low transverse forces occur. The wedge clamp is available with or without position monitoring.

Special features:

- ◆ transverse forces are absorbed by drill bushes; high functional reliability is ensured by position monitoring and automatic cycle
- ◆ rugged and compact design
- ◆ well-proven clamping element with high degree of safety and long service life
- ◆ retracting clamping bolt ensures unrestricted die change
- ◆ clamping and unclamping pressures are different

Please note

In case of incorrect operation of the wedge clamping element, the clamping bolt may fully retract into the guide housing and thus cause the upper die to fall off the slide.

When using wedge clamping elements on press slides or vertical presses it is recommended that multiple-circuit hydraulic supply of the clamping elements and pilot-controlled check valves are used in the clamping lines for securing hydraulic clamping.

The greasing intervals (high-temperature grease) should be scheduled in accordance with the operating conditions (at least once a week). **Greasing of the clamping bolt should only be made with the elements being retracted.**

Position monitoring

The integrated position monitoring system is coupled to the clamping bolt and signals:

1. Clamping bolt in home position
2. Clamping bolt in extended position



Subject to technical modification

2. 2451

05/2011



ROEMHELD
HILMA ■ STARK

Wedge clamp, double-acting Type A - Clamping force axially applied to the clamping edge

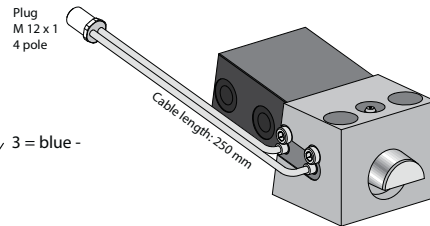
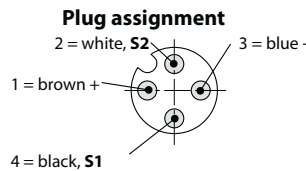
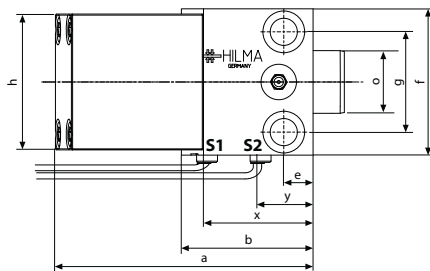
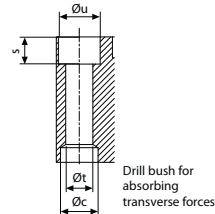
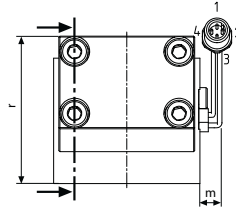
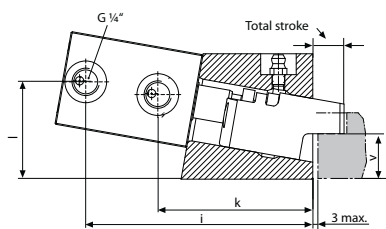
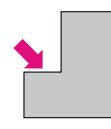

Standard mounting grid (comparable to wedgeclamp 2.2400)

Euromap mounting grid (comparable to wedge clamp 2.2460)

	16	40	60	16	40	60
Max. clamping force * (kN)	16	40	60	16	40	60
Perm. retention force** (kN)	35	60	120	35	60	120
Screw property class 8.8						
Max. clamping pressure (bar)	120	120	120	120	120	120
Max. unclamping pressure (bar)	200	200	200	200	200	200
Cylinder-Ø (mm)	25	40	50	25	40	50
Total stroke (mm)	20	25	25	20	25	25
Max. oil consumption (cm ³)	10	32	50	10	32	50
Clamping stroke (mm)	12	16	17	12	16	17
a (mm)	123	160	197	123	176	197
Ø c H7 x depth (mm)	18H7 x 7	26H7 x 9	30H7 x 11	18H7 x 7	26H7 x 9	30H7 x 11
b (mm)	60	78	109	60	95	109
e (mm)	14	16	20	15	33	32
f (mm)	70	95	120	95	100	140
g (± 0,2 mm)	48	65	85	70	70	105
h (mm)	65	85	100	65	85	100
i (mm)	109	142	180	109	158	180
k (mm)	75	99	131	75	115	131
l (mm)	36	50	65	36	50	65
m (mm)	12	5	0	0	0	0
Ø o (mm)	30	40	55	30	40	55
r (mm)	60	81	103	60	81	103
s (mm)	13	17	20	13	17	20
Ø t (mm)	13	17	21	13	17	21
Ø u (mm)	20	26	32	20	26	32
v** (± 0,1) (mm)	22	25	35	22	25	35
x (mm)	52	68	100	52	85	100
y (mm)	27	29	75	27	45	75
Weight (kg)	2,5	6,0	11,0	2,5	6,0	11,0
with position monitoring						
Part no. up to 100°C*	8.2403.5120	8.2404.5120	8.2405.5120	8.2403.5130	8.2404.5130	8.2405.5130
without position monitoring						
Part no. up to 160°C*	8.2403.5020	8.2404.5020	8.2405.5020	8.2403.5030	8.2404.5030	8.2405.5030
Accessories Drill bushes DIN 179	12 x 12	17 x 16	21 x 20	12 x 12	17 x 16	21 x 20
Part no.	3300 285	3300 287	3300 288	3300 285	3300 287	3300 288

* Temperatures up to 250°C on request ** Clamping edge height: on request to Euromap standard, tolerance ± 0.1 mm

2.2451

06/2011

Subject to technical modification

Wedge clamp, double-acting, type V for dies with flat clamping edge



ROEMHELD
HILMA ■ STARK

Type V - Clamping force vertically applied to the clamping edge

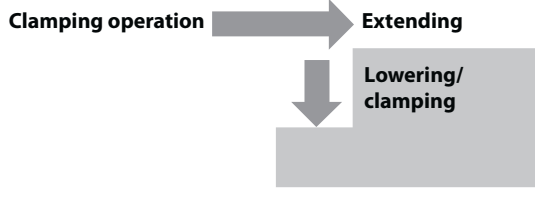
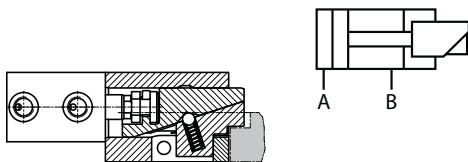

Please note:

In case of incorrect operation of the wedge clamping element, the clamping bolt may fully retract into the guide housing and thus cause the upper die falling off the slide.

When using wedge clamping elements on the press slide, it is recommended that multiple-circuit hydraulic supply of the clamping elements and pilot-controlled check valves are used for securing hydraulic clamping.

The greasing intervals (high-temperature grease) should be scheduled in accordance with the operating conditions (at least once a week). **Greasing of the clamping bolt should only be made with the elements being retracted.**

Clamping elements with a wedge clamping bolt must be protected against dirt, scale, swarf, coolant, etc. by means of a suitable covering. If penetration of such foreign matters cannot be prevented, this type of element should not be used.

Position monitoring

The integral position monitoring system is connected to the thrust pad and signals the following conditions:

1. Thrust pad in initial position
2. Thrust pad in extended position

Application:

- safe clamping of dies with flat clamping edge, even in case of pressure loss
- for clamping of dies in injection moulding machines
- for clamping of dies on press bed and slide

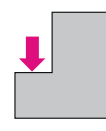

Design:

Double-acting wedge clamp for clamping dies on the press bed or slide or for clamping dies in injection moulding machines.

The wedge clamp consists of a hydraulic block cylinder and a two-piece thrust pad.

Clamping cycle: the bolt with the thrust pad first performs a defined idle stroke. When the inner stop is reached, the thrust pad is lowered onto the clamping edge.

The angle of the thrust pad has been determined to ensure that despite self-locking the oil pressure required for unclamping is not higher than that required for clamping.

Since the clamping force is vertically transmitted to the clamping point, no transverse forces occur.

The wedge clamp is available with or without position monitoring.

Special features:

- ◆ the clamping piston does not retract in the case of pressure drop
- ◆ available in sizes of 25 kN, 50 kN and 100 kN
- ◆ high functional reliability ensured by position monitoring and automatic cycle
- ◆ rugged and compact design
- ◆ special versions available on request
- ◆ well-proven clamping element with high degree of safety and long service life
- ◆ retracting clamping bolt ensures unrestricted die change

Subject to technical modification

2.2460

1

05/2011



ROEMHELD
HILMA ■ STARK

Wedge clamp, double-acting Type V - Clamping force vertically applied to the clamping edge

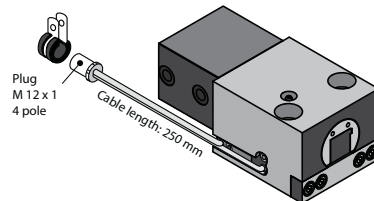
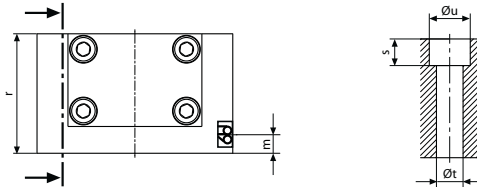
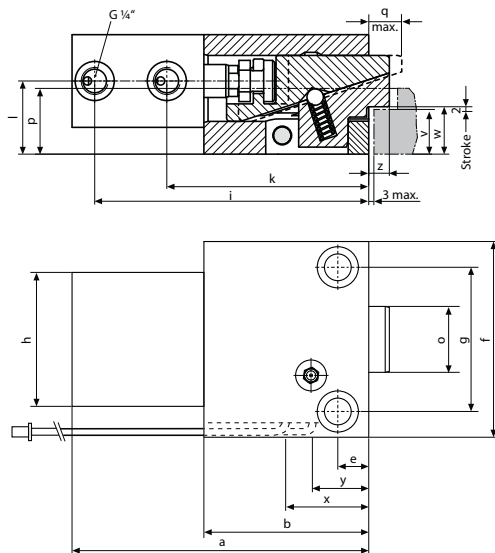
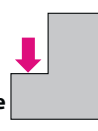

Connecting lead with screw coupling:
cable length 5 m **part no. 5700013**
cable length 10 m **part no. 5700014**

Proximity switch (Twin Set):
part no. 2.5012.0073 (spare part)

Technical data - Position monitoring

Tripping function	N/O contact
Type	PNP
Nom. tripping cycle S_n	1 mm
Ambient temperature T_A	-25°C ... + 100°C *
	Ambient temperature 120° for 1000 working hours.
Operating voltage U_B	10 ... 30 V DC
Residual ripple/supply frequency	≤ 15% (SS)
Max. constant current	100 mA
Unit power consumption	≤ 10 mW
Voltage drop U_D at I max.	≤ 1,5 V
Output resistance R_A	4,7 kΩ
Material of housing	corrosion-proof steel
Type of connection *2	plug on the right side
Protective system acc. to DIN 40050	IP 67

Cable length: 250 mm

* **A design to withstand higher temperatures is available on request**

Pin assignment:

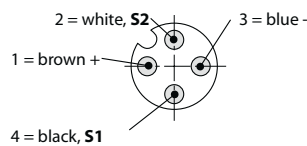

Max. clamping force (kN)	25	50	100
Perm. retention force (kN)			
Schraube DIN 912 8.8	35	65	130
Screw DIN 912 12.9	45	75	145
Max. operating pressure (bar)	250	250	250
Cylinder-Ø (mm)	25	40	50
Max. stroke	2	2	2
Max. oil consumption (cm ³)	10	31	49
Clamping stroke (mm)	1	1	1
a (mm)	144	196	240
b (mm)	80	117	150
e (mm)	15	33	32
f (mm)	95	100	140
g (± 0,2 mm)	70	70	105
h (mm)	65	85	100
i (mm)	133	185	227
k (mm)	98	141	177
l (mm)	35,5	48,5	62,5
m (mm)	9	9	17
Ø o (mm)	32	50	60
p (mm)	32	43	56
q max. (mm)	17	24	24
r (mm)	58	80	100
s (mm)	13	16	22
Ø t (mm)	13	17	21
Ø u (mm)	20	26	32
v** (± 0,3) (mm)	22	25	35
w (mm)	23	26	36
x (mm)	39	65	85
y (mm)	26	47	50
z (mm)	10	17	17
Weight (kg)	4,28	9,55	15,20
with position monitoring			
up to 100°C Part no.	8.2403.6601	8.2404.6611	8.2405.6621
without position monitoring			
up to 160°C Part no.	8.2403.6800	8.2404.6810	8.2405.6820

**Clamping edge height: on request to Euromap standard, tolerance ±0.3 mm

2.2460

05/2011

Subject to technical modification

2

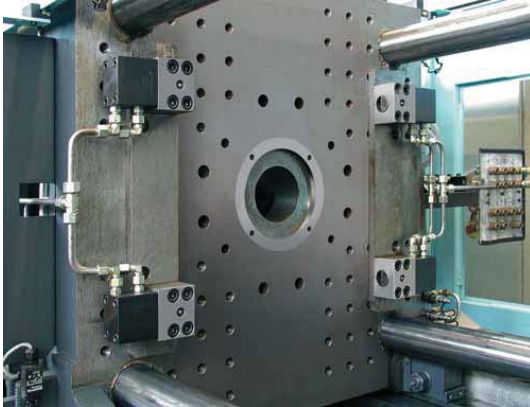

Wedge clamp on a Demag Ergotech 250/630 injection moulding machine



Wedge clamp with check valve on a Krauss Maffei KM 575 injection moulding machine



Wedge clamp in a forging die
Temperatures up to 250°C



Wedge clamp with 160 kN clamping force on a Windsor W 550

Subject to technical modification

3

2.2460

05/2011



ROEMHELD
HILMA ■ STARK

Safety levels for the installation of wedge clamps

Safety requirements are defined by safety regulations and manufacturing technology. In accordance with up to date practice hydraulic die clamping systems are divided into 3 safety levels.

1st safety level:

Preferably used in connection with post-guided dies.

Pressure switches in each clamping circuit for clamping force control as machine safety.

Two hydraulic circuits independent of each other.

Clamping circuit 1 = 50% of the clamping elements in the bed and the slide, respectively

Clamping circuit 2 = 50% of the clamping elements in the bed and the slide, respectively

If one circuit fails, the upper or lower die is still clamped with 50% of the total clamping force. Thus, the 2nd clamping circuit becomes a safety circuit.

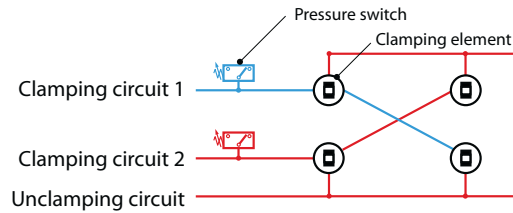

2nd safety level:

Used in connection with dies that are not post-guided.

A check valve (pilot-controlled) keeps pressure in the clamping and safety circuit when pressure drops in the remaining system.

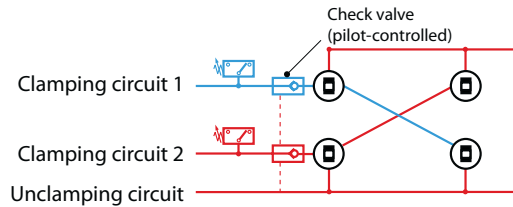

3rd safety level:

Used in connection with dies on power presses and car body presses that are not post-guided.

All clamping elements are secured by pilot-controlled check valves. In the event of pressure drop > 20% of the operating pressure, the press is switched off by a pressure switch. The check valves ensure that the clamping force is maintained over many days.

For this safety level, **wedge clamps with locking bolts and valve sequence controls are used. Maximum safety by standard wedge clamps.**

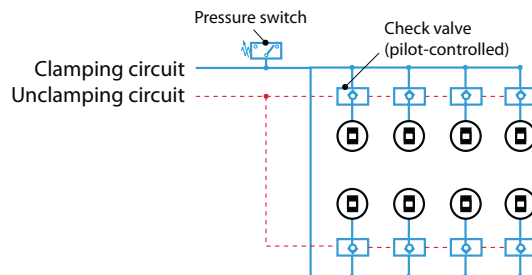

2.2460

05/2011

Subject to technical modification

4