

Electric Drives
and Controls

Hydraulics

Linear Motion and
Assembly Technologies

Pneumatics

Service

Rexroth
Bosch Group

1/12

Pressure relief valve, pilot operated

RE 25802-XC-B2/01.07

Type DB...5X/...XC

Nominal sizes (NG) 10, 20, 30
Unit series 5X
Maximum operating pressure 350 bar

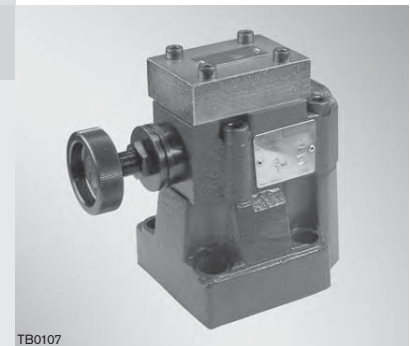

TB0107

ATEX units
For potentially explosive atmospheres

Part II Technical Data Sheet



Information on explosion protection:

- Range of application in accordance with the
Explosion Protection Directive and type of protection
- Range of application as per Directive
RL 94/9/EG IM2, II2G, II2D
 - Type of protection of valve: c (EN 13463-5:2001-01)

What you need to know about these Operating Instructions

These Operating Instructions apply to the explosion-proof version of Rexroth valves,
and consist of the following three parts:

- Part I General Information RE 07010-X-B1
- Part II Technical Data Sheet RE 25802-XC-B2
- Part III Product-specific Instructions RE 25802-XC-B3

Mat. No. R901155669

You can find further information on the correct handling of Rexroth hydraulic products in our publication
"General Product Information for Hydraulic Products", RE 07008.

Overview of Contents

Contents	Page
Features	2
Ordering data and scope of delivery	3
Function, sectional diagram, symbols	4
Technical data	5
Information on explosion protection	5
Characteristic curves	6, 7
Unit dimensions	8...10
Solenoid-operated relief	11, 12

Features

- For subplate mounting, mounting hole configuration to:
ISO 6264-AR-06-2-A (NG10),
ISO 6264-AS-08-2-A (NG20),
ISO 6264-AT-10-2-A (NG30)
- For threaded connection
- Type of adjustment: rotary knob
- 5 pressure stages
- Subplates (see page 10)

Note:

By adding an additional type 3WE 6... spool-type directional control valve, you can expand the valve in such a way that it can feature solenoid-operated relief (see pages 11 and 12).

Ordering data and scope of delivery

	DB		1	5X/				XC	V	
Pilot operated pressure relief valve										V = FKM seals
Nominal size (NG)	= 10, 20, 30									
Type of connection										
Valve for subplate mounting	= -									
Valve for threaded connection	= G									
Type of adjustment										
Rotary knob	= 1									
With main piston Ø24 mm (NG10, NG20)	= -									
With main piston Ø28 mm (NG30 only)	= N									
Unit series 50 to 59 (50 to 59: installation and connection dimensions unchanged)	= 5X									
Set pressure up to 50 bar	= 50									
Set pressure up to 100 bar	= 100									
Set pressure up to 200 bar	= 200									
Set pressure up to 315 bar	= 315									
Set pressure up to 350 bar	= 350									
										XC = Valve in explosion-proof design, see information on explosion protection, page 5 for details
										No code = Standard version
										U = Valve for minimum opening pressure (only possible up to pressure stage 315 bar)
										Control oil flow
										- = Internal control oil supply and return
										X = External control oil supply, internal return
										Y = Internal control oil supply, external return
										XY = External control oil supply and return

Included in scope of delivery:

Valve operating instructions

Function, sectional diagram, symbols

DB type valves are pilot operated pressure relief valves and are used to limit the operating pressure. They basically consist of the main valve (1) with main piston cartridge (3), the pilot valve (2) and the sealing plate (16).

The available pressure in channel P acts on the main piston (3). At the same time, the pressure is applied to the spring-loaded end of the main piston (3) and to the ball (8) in the pilot valve (2) via the control lines (6) and (7), which are equipped with nozzles (4). If the pressure in channel P rises above the value set at the spring (9), the ball (8) opens against the spring (9). The signal that triggers this arrives internally from channel P via the control lines (10) and (6). The pressure fluid at the spring-loaded end of the main piston (3) now flows through

the control line (7), nozzle hole (11) and ball (8) into the spring chamber (12). From here, it is conveyed to the tank internally via control line (13) in the DB...-... type valve, and externally via control line (14) in the DB...Y... type valve. The nozzles (4) and (5) lead to a drop in pressure at the main piston (3), so that the connection from channel P to channel T is now free. The pressure fluid now flows from channel P to channel T, and the set operating pressure is maintained.

The pressure relief valve can be relieved from pressure or switched to a different pressure (second pressure stage) via the port "X" (15).

Type DB 10...XC...

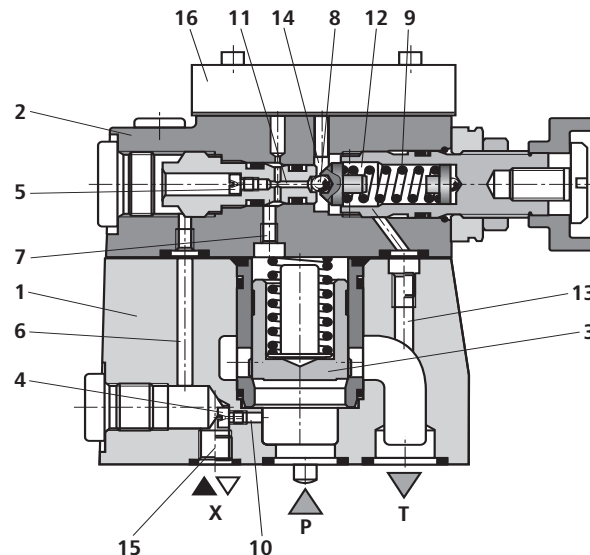

Type DB...-...

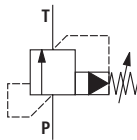

Type DB...X...

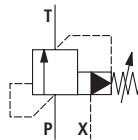

Type DB...Y...

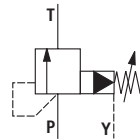

Type DB...XY...

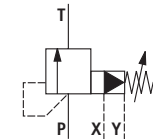

Note:

Hydraulic counter pressures in port T with an internal control oil return or in port Y with an external control oil return are added in the ratio of 1:1 to the response pressure of the valve that is set in the pilot control.

Example:

Pressure setting of valve through spring pre-tension (item 12) in the pilot valve/setting unit.

$$p_{\text{spring}} = 200 \text{ bar}$$

Hydraulic counter pressure in port T with internal control oil return $p_{\text{hydraulic}} = 50 \text{ bar}$

$$\Rightarrow \text{response pressure} = p_{\text{spring}} + p_{\text{hydraulic}} = 250 \text{ bar}$$

Technical data

General

Nominal size		NG10	NG20	NG30	
Installation position		Optional			
Ambient temperature range	°C	-20...+80			
Storage temperature range	°C	-20...+80			
Weight	Subplate mounting - DB...	kg	2.6	3.5	4.4
	Threaded connection - DB...G	kg	5.3	5.1	4.8
Surface protection	Standard	Paint, layer thickness max. 100 µm			

Hydraulic

Maximum working pressure	- Ports P, X	bar	350		
	- Port T	bar	315		
Maximum counter pressure	- Port Y (DB)	bar	315		
	- Ports Y, T (with spool-type directional control valve)	bar	See Technical Data Sheets listed in table on page 11		
Maximum set pressure ¹⁾		bar	50; 100; 200; 315; 350		
Minimum set pressure ¹⁾			Dependent on flow rate (see characteristic curves on page 6)		
Maximum flow rate	- Subplate mounting	l/min	250	500	650
	- Threaded connection	l/min	250	500	650
Pressure fluid			Mineral oil (HL, HLP) to DIN 51524, rapidly biodegradable pressure fluids to VDMA 24568 (also see RE 90221), HETG (rapeseed oil); HEPG (polyglycols); HEES (synthetic ester) Ignition temperature > 180 °C		
Pressure fluid temperature range		°C	-20...+80		
Viscosity range		mm ² /s	10...800		
Maximum permissible degree of contamination of pressure fluid Purity class to ISO 4406 (c)			Class 20/18/15 ²⁾		

Information on explosion protection

Range of application as per Directive RL 94/9/EG		IM2, II2G	II2D
Type of protection of valve		c (EN 13463-5:2001-01)	c (EN 13463-5:2001-01)
Maximum surface temperature ³⁾	°C	-	115
Temperature class		T4	-
Degree of protection		-	IP 65

¹⁾ In order to prevent the maximum permitted response pressure from being exceeded in the system, it must be checked with a suitable measuring instrument during the setting process.

²⁾ The purity classes stated for the components must be complied with in hydraulic systems. Effective filtration prevents problems and also extends the service life of components. For a selection of filters, see Technical Data Sheets RE 50070, RE 50076 and RE 5008.

³⁾ As high surface temperatures may occur, European standards EN 563 and EN 982 on the prevention of accidental contact must be observed.

Characteristic curves (measured with HLP46, $\vartheta_{oil} = 40\text{ °C} \pm 5\text{ °C}$)

Standard version

Minimum set pressure and circulating pressure as a function of the flow rate ¹⁾

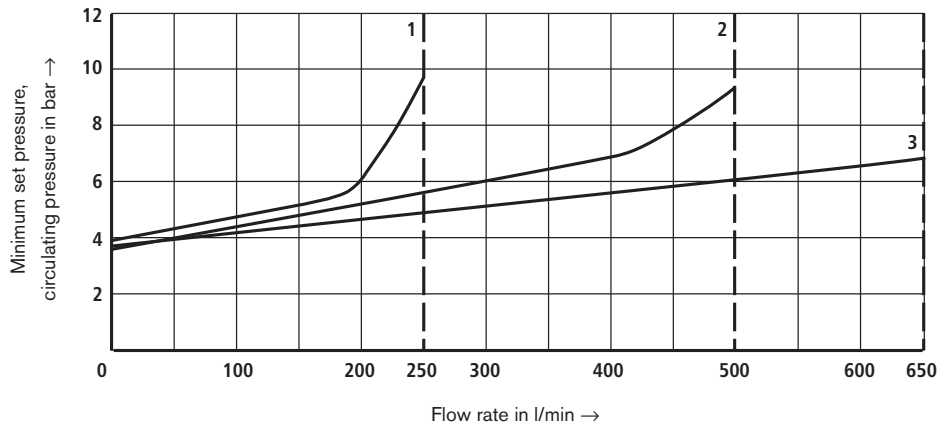

- 1 NG10
- 2 NG20
- 3 NG30

Version „U“

Minimum set pressure and circulating pressure as a function of the flow rate ¹⁾

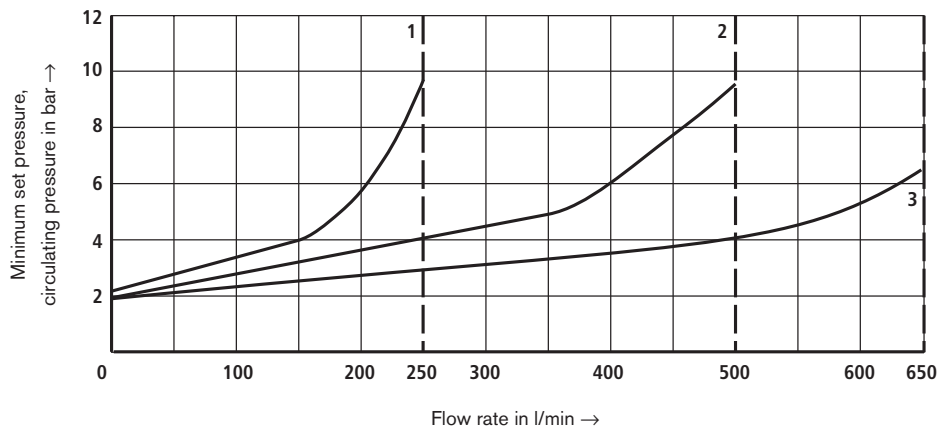

- 1 NG10
- 2 NG20
- 3 NG30

Important!

The characteristic curves were measured with **external, non-pressurized control oil return.**

If the control oil return is internal, the inlet pressure increases by the amount of outlet pressure at port T.

¹⁾ The curves apply to outlet pressure $p_1 = 0$ over the entire flow range!

Characteristic curves (measured with HLP46, $\vartheta_{oil} = 40\text{ °C} \pm 5\text{ °C}$)

Inlet pressure as a function of the flow rate

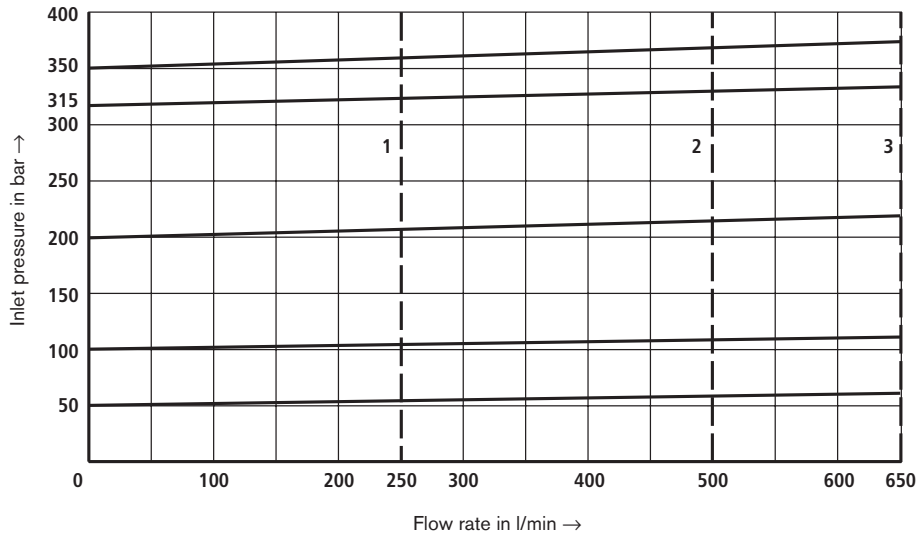

- 1 NG10
- 2 NG20
- 3 NG30

Important:

The characteristic curves were measured with **external, non-pressurized control oil return.**

If the control oil return is internal, the inlet pressure increases by the amount of outlet pressure at port T.

Control oil flow rate

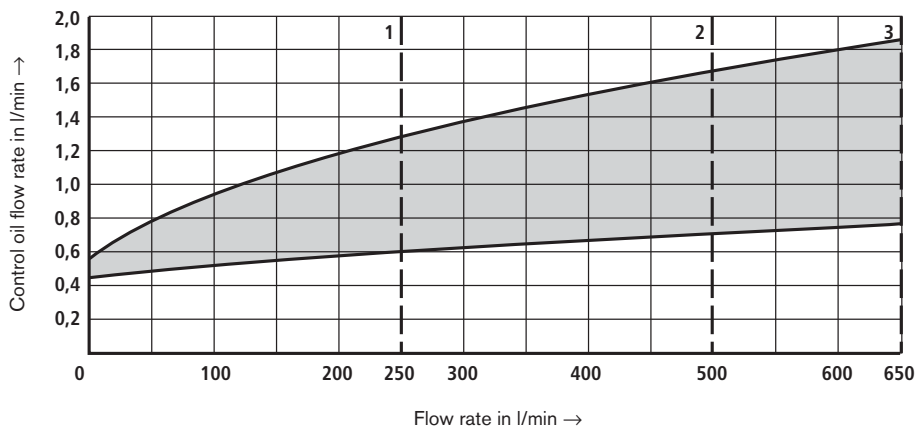

- 1 NG10
- 2 NG20
- 3 NG30

Unit dimensions: Subplate mounting (nominal dimensions in mm)

Type DB.-...XC...

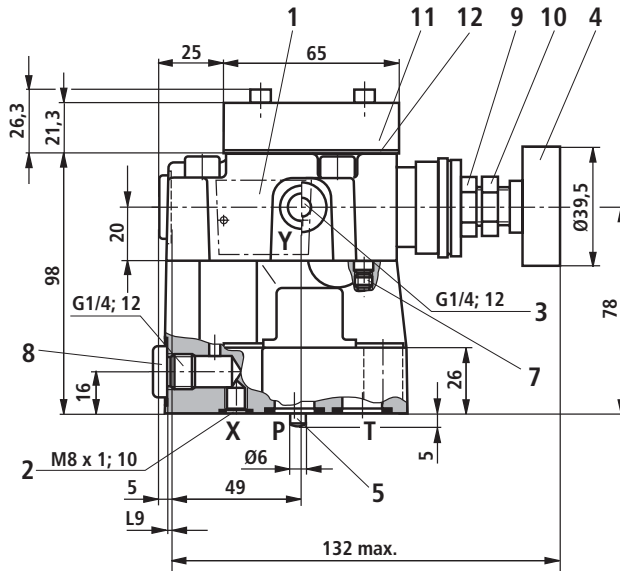

See page 10 for legend to item numbers

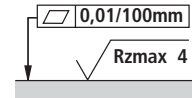

Required surface quality of mating component

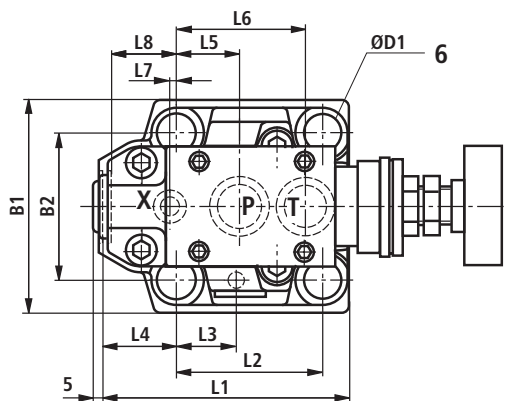

Typ	L1	L2	L3	L4	L5	L6	L7	L8	L9	B1	B2	ØD1
DB 10	91	53.8	22.1	27.5	22.1	47.5	0	25.5	2	78	53.8	14
DB 20	116	66.7	33.4	33.3	11.1	55.6	23.8	22.8	10.5	100	70	18
DB 30	147.5	88.9	44.5	41	12.7	76.2	31.8	20	21	115	82.6	20

Unit dimensions: Threaded connection (nominal dimensions in mm)

Type DB.G...XC...

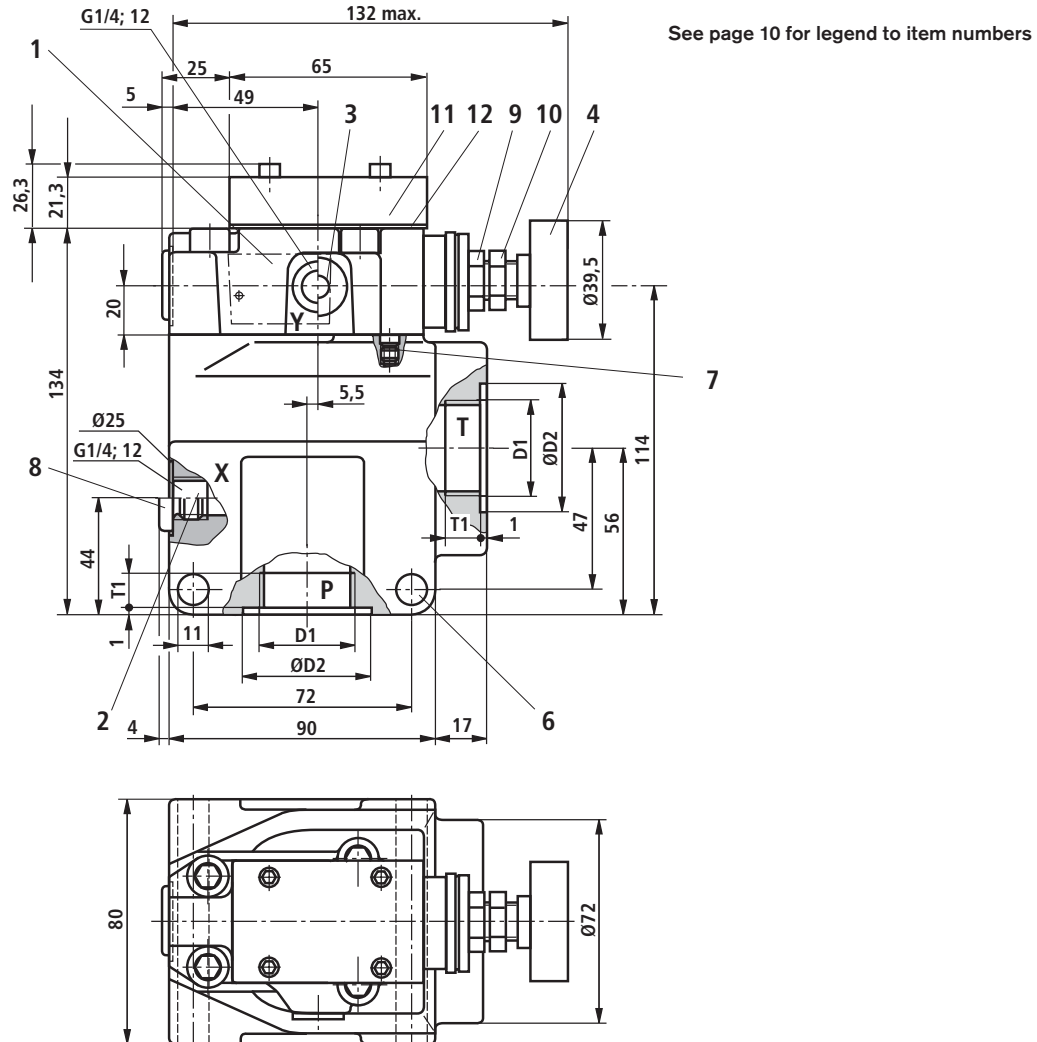

Type	D1	ØD2	T1
DB 10 G	G1/2	34	14
DB 15 G	G3/4	42	16
DB 20 G	G1	47	18
DB 25 G	G1 1/4	58	20
DB 30 G	G1 1/2	65	22

Unit dimensions: Legend to item numbers

- 1 Nameplate
- 2 Port X for external control oil supply
- 3 Port Y for external control oil return
- 4 Type of adjustment "1"
- 5 Dowel pin
- 6 Valve mounting bore
- 7 Not present with internal control oil return
- 8 Test port
- 9 Lock nut (SW17)
- 10 Lock nut (SW17)
- 11 Cover plate
- 12 Sealing plate

Subplates as per Technical Data Sheed RE 45064
(order separately)

Valve type	Type	Mat. no.
DB 10	G 546/01 FE/ZN (G1/2)	R901156999
DB 20	G 409/01 FE/ZN (G1)	R901018328
DB 30	G 411/01 FE/ZN (G1 1/2)	R900580254

Valve fastening bolts for subplate-mounted valves (order separately)

In order to ensure a secure connection, use only the following valve fastening bolts:

- Type DB 10
4 x ISO 4762-M12x50-10.9-flZn-240h-L
(coefficient of friction $\mu_{tot} = 0.09-0.14$)
Material No. **R913000283**
- Type DB 20
4 x ISO 4762-M16x50-10.9-flZn-240h-L
(coefficient of friction $\mu_{tot} = 0.09-0.14$)
Material No. **R913000378**
- Type DB 30
4 x DIN 912-M18x50-10.9
Material No. **R900002245**

Valve fastening bolts for threaded connection valves on request:

- **2 x M10 x ...**
(see unit dimensions on page 9, item 6)

Solenoid-operated relief

With the addition of a type 3WE 6... spool-type directional control valve, the valve can be converted in such a way that it is capable of being electrically switched to non-pressurized circulation (main piston relieved of pressure).

Before adding a 3WE 6... spool-type directional control valve to a DB...5X/...XC pilot operated pressure relief valve, check whether the category and safety class resulting from this combination still satisfy the requirements of the potentially explosive atmosphere in which the valve is to be used.

The spool-type directional control valves for the conversion and the resulting categories and safety classes are set out in the table below.

Important notes:

- The relief function with directional control valve must not be used for safety functions!
- During assembly, please note the operating instructions that are supplied with the spool-type directional control valves.
- Modification or conversion of valves without the use of the operating instructions is not permitted.
- Before assembly, identify all parts by means of their nameplates.

The spool-type directional control valve determines the category to Directive 94/9/EG:

Spool-type directional control valve	Category to 94/9/EG	Technical Data Sheet
3WE 6...5X/...XH	IM2; II2G	RE 23177-XH-B2
3WE 6...6X/...XD	IM2; II2G	RE 23178-XD-B2
3WE 6...6X/...XE	II2G	RE 23178-XE-B2
3WE 6...6X/...XN	II3G; II3D	RE 23178-XN-B2

Example:
DB...5X/...XC plus 3WE 6...6X/...XN ¹⁾ results in suitability for use in category II3G; II3D

¹⁾ When selecting a valve, please also note the possible switching versions on page 12.

Example:

Addition of a 3WE 6...6X/...XE spool-type directional control valve

The assembly of the directional control valve (removal of sealing plate) is described in RE 25802-XC-B3, section 3.4.

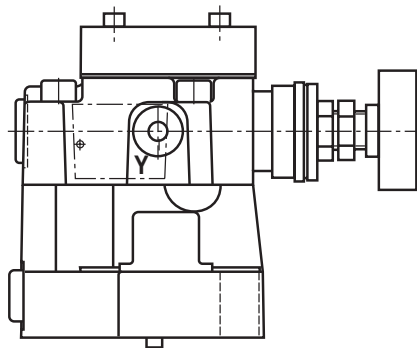
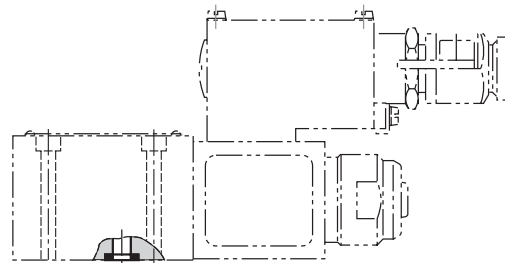

Solenoid-operated relief (continued)

Switching versions

For each type of control oil supply of a DB valve, two switching versions are possible for solenoid-operated relief:

- Closed without current
- Open without current

The choice of piston for the 3WE 6... spool-type directional control valve is determined by the required switching version.

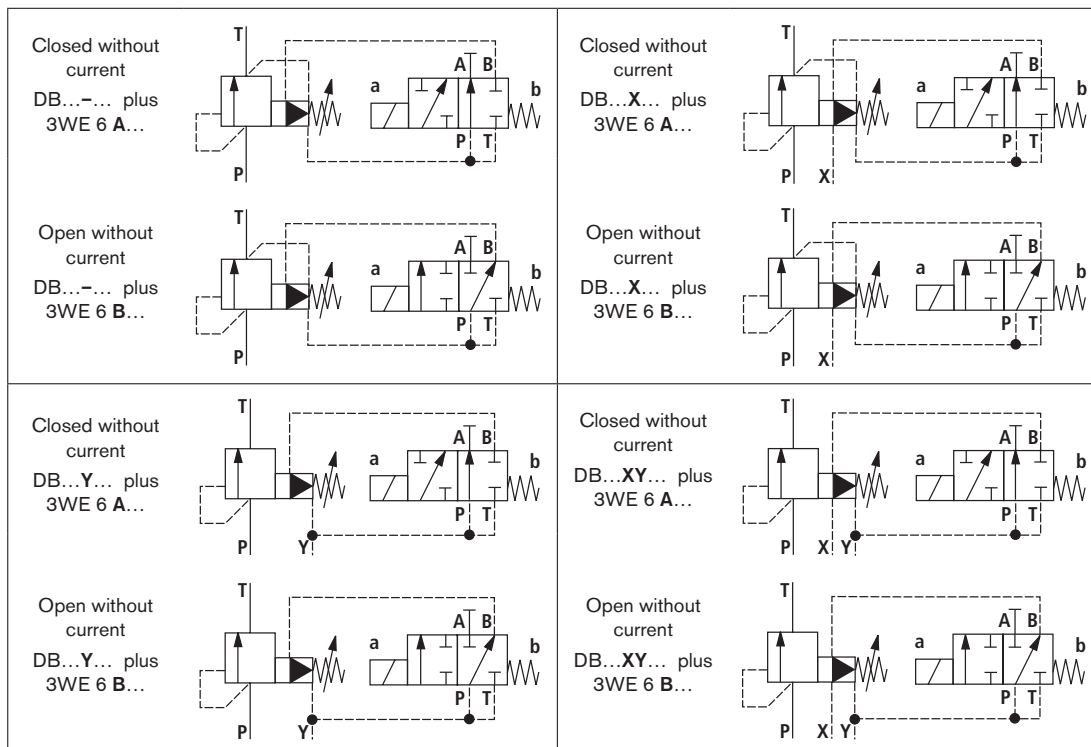

© This document, as well as the data, specifications and other information set forth in it, are the exclusive property of Bosch Rexroth AG. It may not be reproduced or given to third parties without its consent. The data specified above only serve to describe the product. No statements concerning a certain condition or suitability for a certain application can be derived from our information. The information given does not release the user from the obligation of own judgment and verification. It must be remembered that our products are subject to a natural process of wear and aging.