

Electric Drives  
and Controls

Hydraulics

Linear Motion and  
Assembly Technologies

Pneumatics

Service

**Rexroth**  
Bosch Group

## Pressure reducing valve, direct operated

**RE 26585/05.11**  
Replaces: 06.03

1/8

### Type ZDR

Size 10  
Component series 5X  
Maximum operating pressure 210 bar  
Maximum flow 80 l/min



### Table of contents

#### Contents

Features  
Ordering code  
Symbols  
Function, section  
Technical data  
Characteristic curves  
Unit dimensions

### Features

Page	
	– Sandwich plate valve
1	– Porting pattern according to ISO 4401-05-04-0-05
2	– 4 pressure ratings
2	– 4 adjustment types, optional:
3	• Rotary knob
4	• Bushing with hexagon and protective cap
4	• Lockable rotary knob with scale
5	• Rotary knob with scale
6	– Check valve, optional (version "A")
	– Pressure reduction in channel A, B or channel P

## Ordering code

Z	DR	10	D		-5X/	Y		*
Sandwich plate valve = Z	Pressure reducing valve = DR	Size 10 = 10	Direct operated = D	Pressure reduction in channel A <sup>②</sup> = A	Pressure reduction in channel P <sup>①</sup> (pilot oil supply from channel B) = B	Pressure reduction in channel P <sup>①</sup> = P	<b>Adjustment type</b>	Further details in the plain text
				Rotary knob = 1	Bushing with hexagon and protective cap = 2	Lockable rotary knob with scale = 3 <sup>1)</sup>	Rotary knob with scale = 7	<b>Seal material</b>
				Component series 50 to 59 (50 to 59: unchanged installation and connection dimensions) = 5X				No code = NBR seals
								V = FKM seals
								(other seals at request)
								Attention!
								Observe compatibility of seals with hydraulic fluid used!
								No code = With check valve
								(only with version "A")
								M = Without check valve
								Y = Pilot oil supply internal, pilot oil return external
								25 = Secondary pressure up to 25 bar
								75 = Secondary pressure up to 75 bar
								150 = Secondary pressure up to 150 bar
								210 = Secondary pressure up to 210 bar

<sup>1)</sup> H-key with material no. R900008158 is included in the delivery

Standard types and standard units are contained in the EPS (standard price list).

### Note!

For port X and Y bored according to ISO 4401-05-05-0-05 (e.g. for pilot operated directional valve size 10), version "SO30" at the end of the order code applies!

## Symbols (① = component side, ② = plate side)

Type ZDR 10 DP...YM...

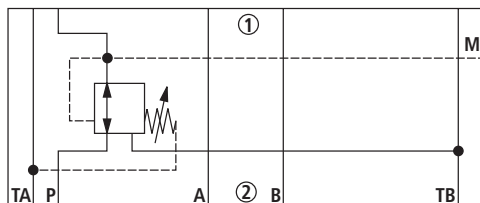

Type ZDR 10 DA...YM...

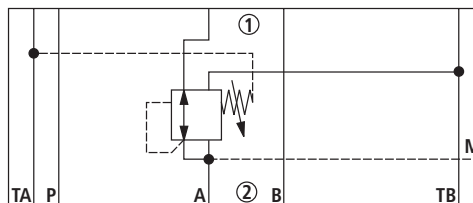

Type ZDR 10 DB...YM...

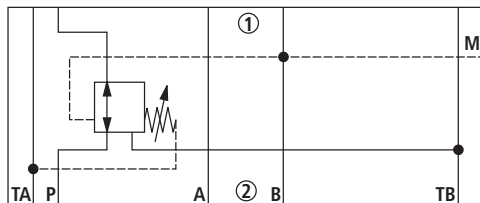

Type ZDR 10 DA...Y...

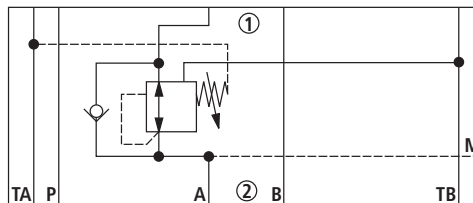

### Note!

Deviating from ISO 4401, port T is in this data sheet called TA, port T1 is called TB.

## Function, section

The valve type ZDR is a direct operated pressure reducing valve in sandwich plate design with pressure limitation of the secondary circuit. It is used to reduce the system pressure.

The pressure reducing valve basically comprises of a housing (1), a control spool (2), a compression spring (3), adjustment type (4) and an optional check valve.

The secondary pressure is set via the adjustment type (4).

### Version "A"

In the initial position the valve is open. Hydraulic fluid can flow from channel A<sup>①</sup> to channel A<sup>②</sup> without limitation. Via the pilot line (5), the pressure in channel A<sup>②</sup> is simultaneously applied to the spool face vis-à-vis the compression spring (3). If the pressure in channel A<sup>②</sup> rises above the value set at the compression spring (3), the control spool (2) moves against the compression spring (3) into the control position and thereby holds the set pressure in channel A<sup>②</sup> constant.

Control signal and pilot oil are provided internally, via the control line (5), from channel A<sup>②</sup>.

If the pressure in channel A<sup>②</sup> continues to increase due to external forces at the actuator, the control spool (2) moves further against the compression spring (3).

Thus, channel A<sup>②</sup> is, via control edge (6) at the control spool (2) and housing (1) connected with the tank (channel TB). Hydraulic fluid continues to flow to the tank until the pressure no longer increases.

The leakage oil drain from the spring chamber (7) is always external, via channel TA.

A pressure gauge connection (8) allows for the control of the secondary pressure at the valve.

With version "A", a check valve can be used for free flow back from channel A<sup>②</sup> to A<sup>①</sup>.

### Versions "P" and "B"

With version "P", the pressure is reduced in channel P<sup>①</sup>. Control signal and pilot oil are provided internally, from channel P<sup>①</sup>.

With version "B", the pressure is reduced in channel P<sup>①</sup>, the pilot oil is, however, taken from channel B. If the directional valve is in spool position P to A, the pressure in channel B must not exceed the set secondary pressure. Otherwise, the pressure in channel A will be reduced.

### Attention!

- In case of use without directional valve, channels TA and TB must be connected with each other (e.g. in the cover plate).
- In the set-up of a directional seat valve size 10, a sandwich plate type HSZ10A078-3X/M00 (Material no. R900537264) must be used.

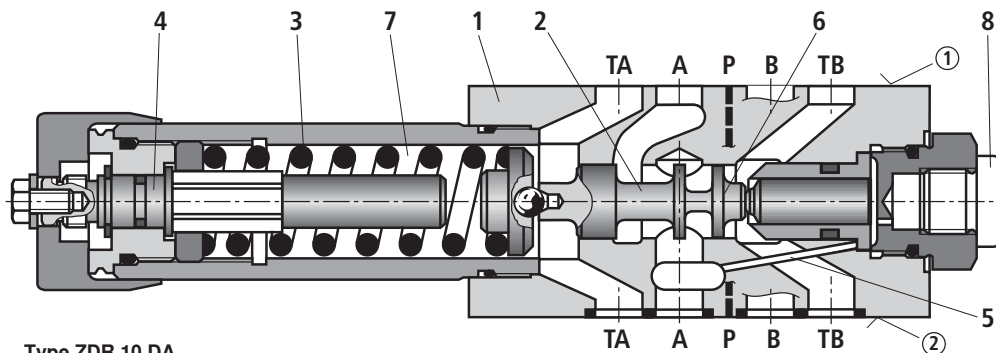

① = component side

② = plate side

## Technical Data (For applications outside these parameters, please consult us!)

### general

Weight	kg	Approx. 2.8
Installation position		Any
Ambient temperature range	°C	-30 to +80 (NBR seals) -20 to +80 (FKM seals)

### hydraulic

Maximum operating pressure – Input	bar	315
Maximum secondary pressure – Output	bar	25; 75; 150; 210
Maximum backpressure – Port T	bar	160
Maximum flow	l/min	80
Hydraulic fluid		See table below
Hydraulic fluid temperature range	°C	-30 to +80 (NBR seals) -20 to +80 (FKM seals)
Viscosity range	mm <sup>2</sup> /s	10 to 800
Maximum permitted degree of contamination of the hydraulic fluid - cleanliness class according to ISO 4406 (c)		Class 20/18/15 <sup>1)</sup>

Hydraulic fluid	Classification	Suitable sealing materials	Standards
Mineral oils and related hydrocarbons	HL, HLP, HLPD	NBR, FKM	DIN 51524
Environmentally compatible	- Insoluble in water	HETG	ISO 15380
	- Soluble in water	HEES	
Flame-resistant	- Water-free	HEPG	ISO 15380
	- Water-free	HFDU, HFDR	ISO 12922
	- Water-containing	HFC (Fuchs Hydrotherm 46M, Petrofer Ultra Safe 620)	NBR

#### Important information on hydraulic fluids!

- For more information and data on the use of other hydraulic fluids refer to data sheet 90220 or contact us!
- There may be limitations regarding the technical valve data (temperature, pressure range, service life, maintenance intervals, etc.)!

#### - Flame-resistant – water-containing:

- Maximum operating pressure 210 bar
- Maximum hydraulic fluid temperature 60 °C
- Expected service life as compared to HLP hydraulic oil 30 % to 100 %

<sup>1)</sup> The cleanliness classes specified for the components must be adhered to in hydraulic systems. Effective filtration prevents faults and at the same time increases the service life of the components.

**Characteristic curves** (measured with HLP46,  $\vartheta_{oil} = 40 \pm 5 \text{ }^\circ\text{C}$ )

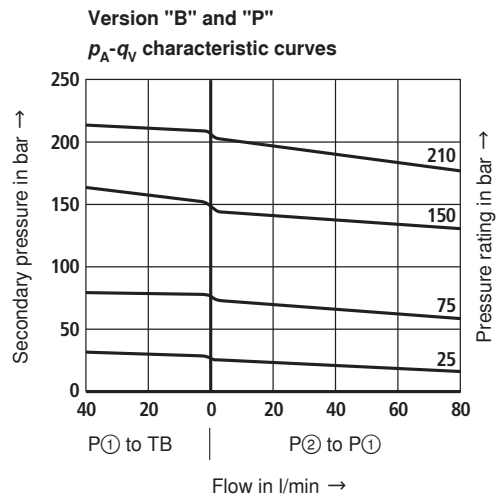
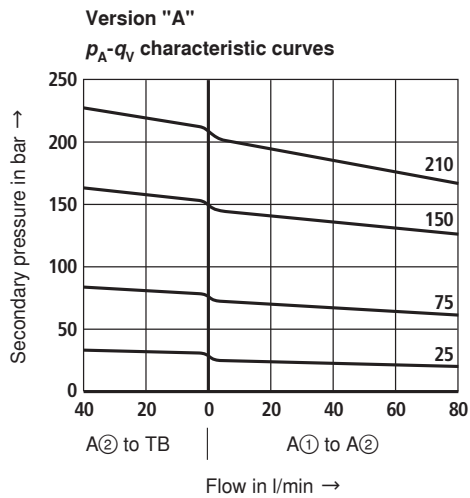

**Note!**

The curve development is maintained according to the pressure rating if the pressure is set lower.

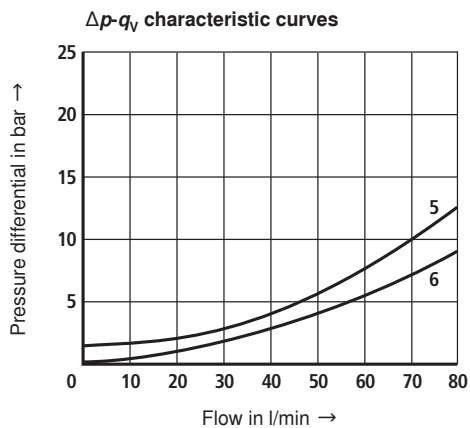
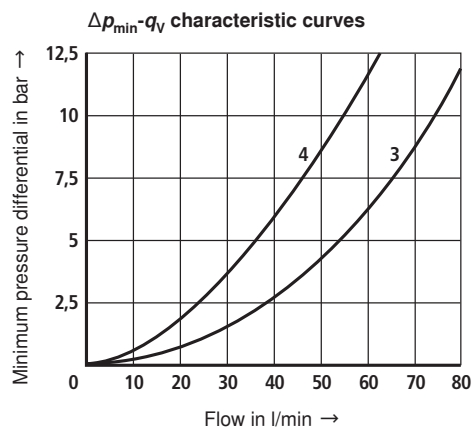
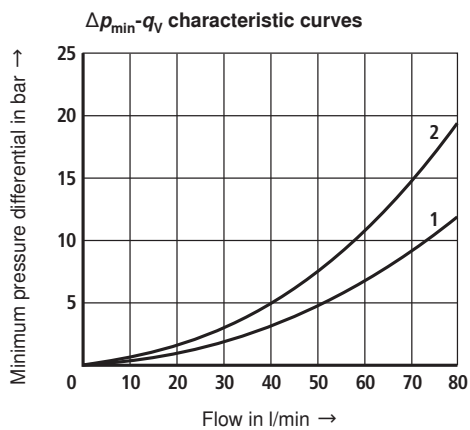

- 1 A(1) to A(2)
- 2 A(2) to TB (3rd way)
- 3 P(2) to P(1)
- 4 P(1) to TB (3rd way)
- 5 A(2) to A(1); flow only via check valve
- 6 A(2) to A(1); flow via check valve and completely opened control cross-section

The characteristic curves apply to the pressure at the valve output  $p_T = 0$  bar across the entire flow range.

## Unit dimensions (dimensions in mm)

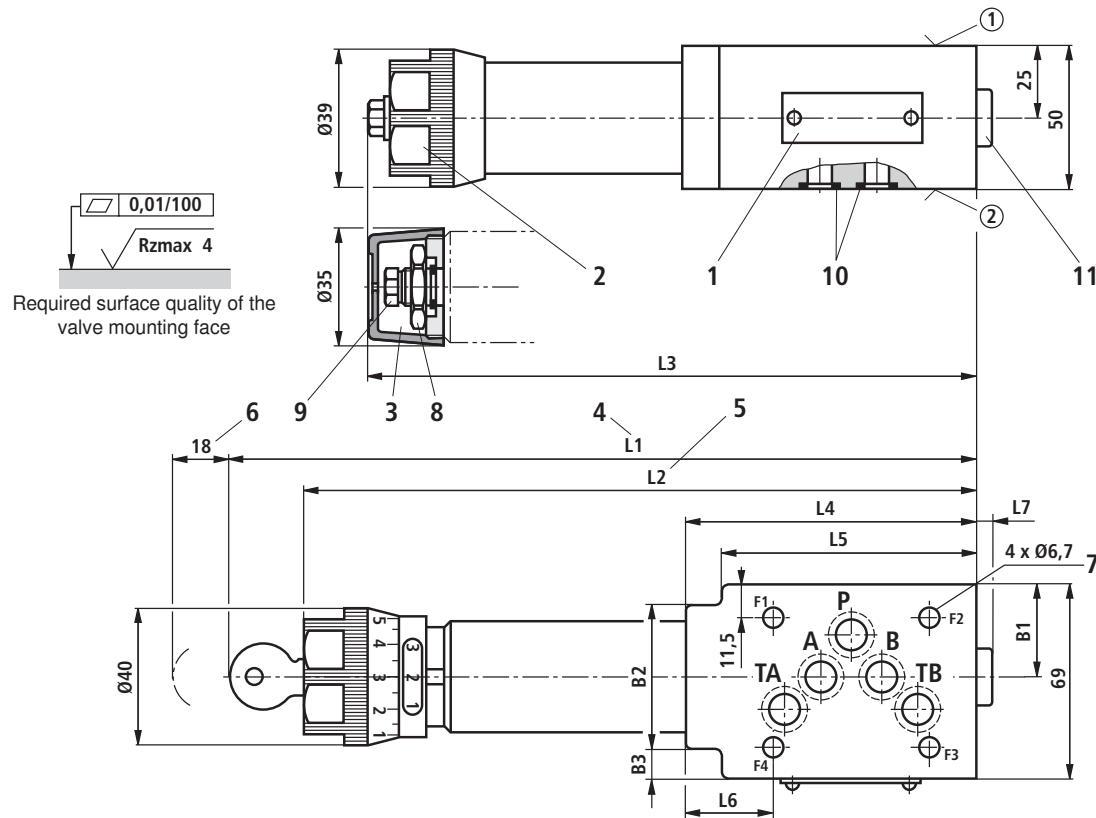

Version	L1	L2	L3	L4	L5	L6	L7	B1	B2	B3
"A"	254	230	210	104	93	31,5	3,8	32,9	51	12
"B" and "P"	242	218	198	91	-	18,5	15,8	35	-	-

- 1 Name plate
- 2 Adjustment type "1"
- 3 Adjustment type "2"
- 4 Adjustment type "3"
- 5 Adjustment type "7"
- 6 Space required to remove the key
- 7 Valve mounting bores
- 8 Lock nut SW24
- 9 Hexagon SW10
- 10 Identical seal rings for ports A, B, P, TA and TB
- 11 Pressure gauge connection G1/4; 12 deep; internal hexagon SW6

Valve mounting screws (separate order)

4 hexagon socket head cap screws ISO 4762 - M6 - 10.9

### Notes!

- Length and tightening torque of the valve mounting screws must be calculated according to the components mounted under and over the sandwich plate valve.
- For port X and Y bored according to ISO 4401-05-05-0-05 (e.g. for pilot operated directional valve size 10), version "SO30" at the end of the order code applies!
- Deviating from ISO 4401, port T is in this data sheet called TA, port T1 is called TB.

① Component side – porting pattern according to ISO 4401-05-04-0-05

② Plate side – porting pattern according to ISO 4401-05-04-0-05

## Notes

---

© This document, as well as the data, specifications and other information set forth in it, are the exclusive property of Bosch Rexroth AG. It may not be reproduced or given to third parties without its consent. The data specified above only serve to describe the product. No statements concerning a certain condition or suitability for a certain application can be derived from our information. The information given does not release the user from the obligation of own judgment and verification. It must be remembered that our products are subject to a natural process of wear and aging.