

The Drive & Control Company

**Rexroth**  
Bosch Group

## Valve amplifier for proportional valves

Type VT-SSPA1-1(5, 50, 100, 150)

**RE 30116**

Edition: 2014-07

Replaces: 04.14



H7072+7645

- ▶ Component series 1X
- ▶ Analog, connector design
- ▶ Suitable for controlling solenoid-actuated pressure and directional valves without position control (see page 2)

### Features

- ▶ Proportional command value/current characteristic curve for command values between 0 and 100%
- ▶ Regulated adjustable maximum current for command values greater than approx. 120% (for differential input only)
- ▶ Differential input
- ▶ Separate up/down ramp generator
- ▶ Zero potentiometer / pilot current
- ▶ Command value attenuator / maximum current
- ▶ Dither frequency potentiometer
- ▶ 24 V operating voltage

### Contents

Features	1
Ordering code	2
Applications	3
Function	4
Block diagram	4
Characteristic curve	5
Technical data5	
Electrical connection	6
Adjustment elements / dimensions	7
Project planning / maintenance instructions / additional information	8

RE 30116, edition: 2014-04 **Bosch Rexroth AG**

2/8 **VT-SSPA1-1(5, 50, 100, 150)** | Valve amplifier

## Ordering code

01	02	03	04	05	06	07
VT-SSPA1	-	-	1X	/	/	0 - 24 /

01	Valve amplifier for proportional valves, analog, connector design	<b>VT-SSPA1</b>
02	For DBET / DRE / DBEM...7x	<b>1</b>
	For KBPS...8	<b>5</b>
	Universal, 2.5 A	<b>50</b>
	For KKDSR	<b>100</b>
	Universal, 0.8 A	<b>150</b>
03	Component series 10 to 19 (10 to 19: unchanged technical data and pin assignment)	<b>1X</b>
04	Version: Standard	<b>V0</b>
	Version: ramp time: 10 ms to 2 s (only for variant VT-SSPA1-50-1X)	<b>V002</b>
05	Voltage input	<b>0</b>
06	24 V operating voltage	<b>24</b>
07	With cable gland	<b>no code</b>
	With M12 connector	<b>K24</b>

## Type overview

Type	Mat. no.	$U_B$	$I_{rated}$	$f$ with $I_{rated}$	Command value	For valve	Solenoid
VT-SSPA1-1-1X/V0/0-24	R900779643	24 V	1.6 A	340 Hz	0...10 V/24 V	DBET / DRE / DBEM...7x	5.5 $\Omega$
VT-SSPA1-1-1X/V0/0-24/K24	R901238534	24 V	1.6 A	340 Hz	0...10 V/24 V	DBET / DRE / DBEM...7x	5.5 $\Omega$
VT-SSPA1-5-1X/V0/0-24	R901024331	24 V	1.2 A	200 Hz	0...10 V/24 V	KBPS...8	4.77 $\Omega$
VT-SSPA1-5-1X/V0/0-24/K24	R901238530	24 V	1.2 A	200 Hz	0...10 V/24 V	KBPS...8	4.77 $\Omega$
VT-SSPA1-50-1X/V0/0-24	R901005414	24 V	2.5 A	305 Hz	0...10 V/24 V	universal	> 2 $\Omega$
VT-SSPA1-50-1X/V002/0-24	R901336728	24 V	2.5 A	305 Hz	0...10 V/24 V	universal	> 2 $\Omega$
VT-SSPA1-50-1X/V0/0-24/K24	R901238532	24 V	2.5 A	305 Hz	0...10 V/24 V	universal	> 2 $\Omega$
VT-SSPA1-100-1X/V0/0-24	R901030116	24 V	1.2 A	150 Hz	0...10 V/24 V	KKDSR1	7.2 $\Omega$
VT-SSPA1-100-1X/V0/0-24/K24	R901238528	24 V	1.2 A	150 Hz	0...10 V/24 V	KKDSR1	7.2 $\Omega$
VT-SSPA1-150-1X/V0/0-24	R901104644	24 V	0.8 A	150 Hz <sup>1)</sup>	0...10 V	universal	19.5 $\Omega$
VT-SSPA1-150-1X/V0/0-24/K24	R901263782	24 V	0.8 A	150 Hz <sup>1)</sup>	0...10 V	universal	19.5 $\Omega$

<sup>1)</sup>With a solenoid resistance of  $R = 19.5 \Omega$  and a solenoid current of  $I = 100 \text{ mA}$

## Ordering code(continued)

### Accessories for type .../K24

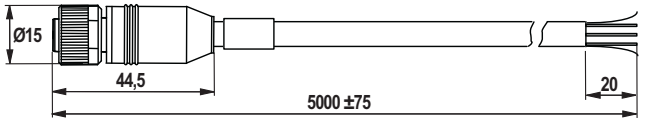
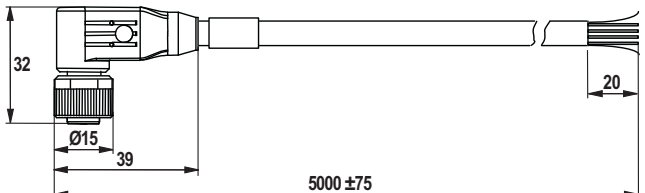
Description	Designation	Mat. no.
Assembled cable with straight mating connector	CABLE SET VT-SSPA1-1X/M12/1/V00	R901241656
	Cable sheath: PVC, black cable sheath Ø: 6.4 mm wire cross-section: 4 x 0.75 mm <sup>2</sup> Cable and mating connector shielded Connection see page 6	
Assembled cable with angular mating connector	CABLE SET VT-SSPA1-1X/M12/2/V00	R901241651
	Cable sheath: PVC, black cable sheath Ø: 6.4 mm wire cross-section: 4 x 0.75 mm <sup>2</sup> Cable and mating connector shielded Connection see page 6	

## Applications

### 2-conductor technology (only with differential input)

- ▶ Switching application with fixed flow control
- ▶ Ramp function upon switch-on

The "IN+" input is bridged with supply voltage (+U<sub>B</sub>) in the connector, the IN- input is bridged with supply voltage (0 V) in the connector.

The maximum current must generally be adjusted according to the solenoid information using potentiometer "G". The ramp time "ramp up" (t <) can be set within the range of t<sub>min</sub> to 5 s.

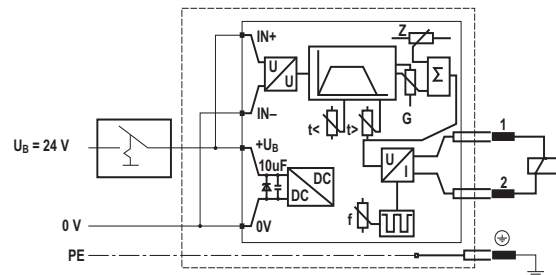

### 3-conductor technology (only with differential input)

- ▶ Switching application with fixed flow control
- ▶ Switching with low control power
- ▶ Ramp function can be adjusted separately when switching on and off the control voltage

The "IN+" input is connected to the control voltage (U<sub>s</sub> = 24 V), the "IN-" input is bridged with supply voltage (0 V) in the connector.

The maximum current must generally be adjusted according to the solenoid information using potentiometer "G". When switched off ("IN+" = 0 V or "IN+" = open) a pilot current can be set at "Z". This serves to reduce the switch-on delay, particularly with ramp. If required, this value can be adjusted between approx. 0 mA and approx. 15% of the rated current. The ramp times "ramp up" (t <) and "ramp down" – (t >) can be set within the range of t<sub>min</sub> to 5 s.

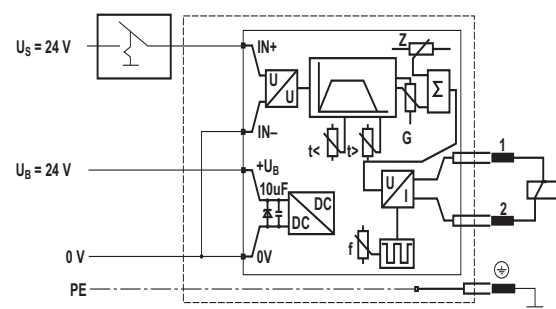

4/8 VT-SSPA1-1(5, 50, 100, 150) | Valve amplifier

## Applications (continued)

### 4-conductor technology

The "IN+" input is connected to the control signal ( $U_s = 0 \dots 10 \text{ V}/24 \text{ V}$ ), the "IN-" input is connected to the reference potential of the control voltage. Pilot current and maximum current are set using potentiometers "Z" and "G" prior to commissioning. The current can now be proportionally adjusted according to the control voltage between the set pilot current and the set maximum current. The pilot current can be set in the range of approx. 0 mA to approx. 15% of the rated current, the maximum current can be set in the range of 0 to  $I_{\max}$  (see technical data page 5).

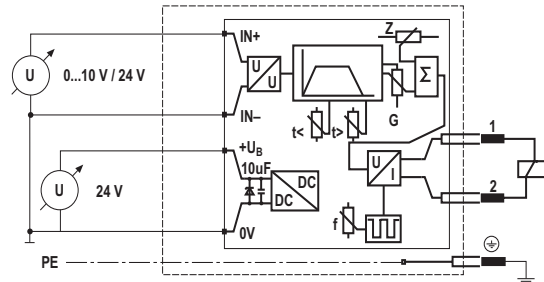

## Function

The plug-in amplifier is suitable for installation on a valve connection base according to EN 175301-803. By turning the plug insert and the electronics in the housing, the plug-in amplifier can be mounted on the solenoid in 90° increments.

### Command value presetting

The command value range is between 0 and  $U_B$ . In the command value range 0... 10 V the solenoid current is proportional to the command value. Starting with a command value of 12 V up to  $U_B$  the solenoid current is almost constant according to the  $I_{\max}$  setting (switching application).

### Ramp generator

The ramp generator (5) limits the rise of the control output. The up and down ramp times can be adjusted separately. In switching applications, the ramps can be used to dampen the switch-on and switch-off impulse. (When switching off only with 3-conductor connection, i.e. switching signal and supply are connected separately.)

This behavior also depends on the valve and solenoid type. The downstream command value attenuator (4) has no influence on the ramp time.

### Characteristic curve

Up to a command value of approx. 110% the transfer characteristic curve rises linearly. The zero point can be corrected using potentiometer "Z", the maximum value can be corrected using potentiometer "G".

### Power output stage

Output stage (7) is freely clocking. The clock frequency depends on the current level, the operating voltage and the impedance of the controlled solenoid. The clock frequency can be re-adjusted using potentiometer "f". The current output stage generates a regulated current signal according to the control output provided by the summing device (3). If the clock frequency is too high, the valve hysteresis is increased. If the clock frequency is too low, the noise level of the hydraulic system is increased.

( ) = Assignment to the block diagram

## Block diagram

- (1) Internal voltage adjustment
- (2) Command value input
- (3) Zero point potentiometer "Z" / pilot current  $I$  ( $IN = 0\%$ )
- (4) Command value attenuator "G" / maximum current  $I$  ( $IN = 100\%$ )
- (5) Ramp time potentiometers " $t <$ " and " $t >$ "
- (6) Frequency range correction " $f$ "
- (7) Power output stage

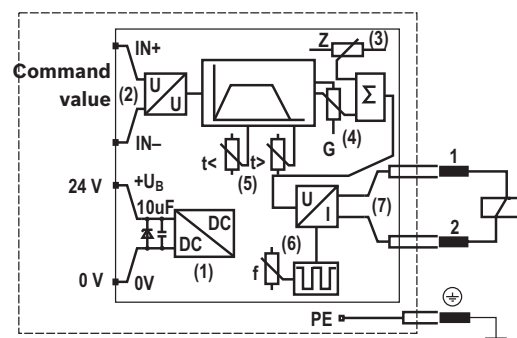

Bosch Rexroth AG, RE 30116, edition: 2014-04

## Characteristic curve

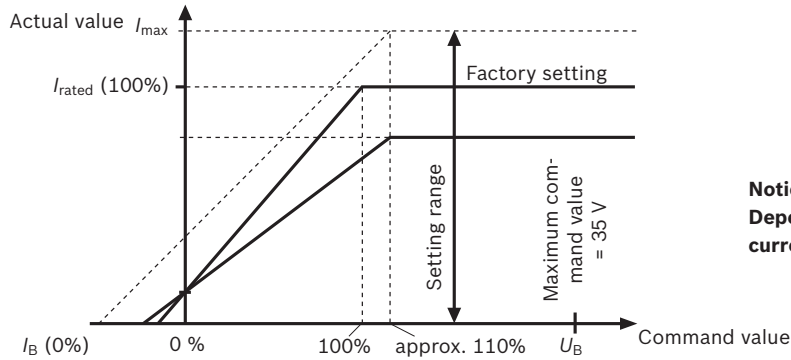

**Notice:**  
Depending on the type, the pilot current can also be "0".

## Technical data (For applications outside these parameters, please consult us!)

Type	VT-SSPA1-1	VT-SSPA1-5	VT-SSPA1-50	VT-SSPA1-100	VT-SSPA1-150
24 V operating voltage	24 VDC				
$U_B$	24 VDC				
$u(t)_{max}$	35 V				
$u(t)_{min}$	18 V				
Maximum cable inductance <sup>1)</sup>	100 $\mu$ H				
$L_{max}$	100 $\mu$ H				
Current and power consumption (dependent on solenoid data)	$I / A$	$I / A$	$I / A$	$I / A$	$I / A$
	< 1.7	< 1.7	< 2.6	< 1.7	< 1.2
	$P_{max} / VA$	$P_{max} / VA$	$P_{max} / VA$	$P_{max} / VA$	$P_{max} / VA$
	< 40	< 40	< 60	< 40	< 30
Recommended pre-fuse	$I / A$	$I / A$	$I / A$	$I / A$	$I / A$
	2; time-lag	2; time-lag	3.15; time-lag	2; time-lag	1.5; time-lag
Minimum coil inductivity	$L_{min} / mH$	$L_{min} / mH$	$L_{min} / mH$	$L_{min} / mH$	$L_{min} / mH$
	15	15	10	15	15
Pilot current (setting range)	$I_B / mA$	$I_B / mA$	$I_B / mA$	$I_B / mA$	$I_B / mA$
	0...300	0...300	0...350	0...250	0...200
Pilot current (factory setting)	$I_B / mA$	$I_B / mA$	$I_B / mA$	$I_B / mA$	$I_B / mA$
	100	0	100	0	100
Rated current (factory setting)	$I / A$	$I / A$	$I / A$	$I / A$	$I / A$
	1.6	1.2	2.5	1.2	0.8
Maximum current (setting range)	$I_{max} / A$	$I_{max} / A$	$I_{max} / A$	$I_{max} / A$	$I_{max} / A$
	$I_B \dots 1.7$	$I_B \dots 1.8$	$I_B \dots 2.6$	$I_B \dots 1.7$	$I_B \dots 0.8$
Clock frequency at $I_{max}$	$f / Hz$	$f / Hz$	$f / Hz$	$f / Hz$	$f / Hz$
	340	200	305	150	150 <sup>2)</sup>
Command value input (voltage)					
Proportional range	$U$	0...10 V			
Switching range	$U$	12 V... $U_B$			
Resistance	$R$	20 k $\Omega$			
Ramp time (setting range)					
Variant V0	$t$	100 ms...5 s	60 ms...5 s		
Variant V002	$t$		10 ms...2 s		
Type of connection (cable gland)	4 screw terminals				
Cable diameter	4.5 ... 11 mm				
Type of connection (M12 connector)	Connector, 4-pole, M12x1				
Type of connection (solenoid)	Base according to EN 175301-803				
Number of poles (solenoid)	2 + PE				
Dimensions	see page 7				
Type of mounting	M3 x 40 mm				
Admissible operating temperature range (amplifier with cable gland)	$^{\circ}C$	-25 ... +70	-25 ... +70	-25 ... +60	-25 ... +70
Admissible operating temperature range (amplifier with M12 connector)	$^{\circ}C$	-25 ... +70	-25 ... +70	-25 ... +50	-25 ... +70
Storage temperature range	$^{\circ}C$	-25 ... +85			
Protection class according to EN 60529	IP65 with mounted cable/mounted mating connector				
Weight	$m$	0.125 kg			

<sup>1)</sup> Usually corresponds to a cable length < 100 m

<sup>2)</sup> With a solenoid resistance of  $R = 19.5 \Omega$  and a solenoid current of  $I = 100 \text{ mA}$

6/8 VT-SSPA1-1(5, 50, 100, 150) | Valve amplifier

## Electrical connection

Terminal / pin		Terminal / pin	
+UB / 1	Operating voltage $U_B$ 24 V	IN+ / 2	Command value input 24 V; 0...10 V
0 V / 3	0 V ground	IN- / 4	Reference potential for the command value

## Terminal connection

Risk of malfunctions in case of EMC/ESD interference on the connection cable

**Do not route command value connection lines through this section!**

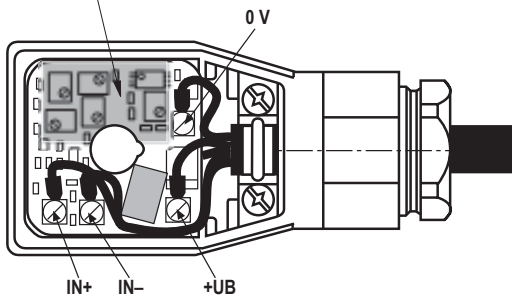

**The connection for the protective earthing conductor is accessible after the electronic printed-circuit board has been removed.**

Connection cross-section:  
4 x 0.75 mm<sup>2</sup> shielded or  
5 x 0.5 mm<sup>2</sup> shielded (connect shield in control cabinet)  
For VT-SSPA1-50:  
4 x 1.5 mm<sup>2</sup> shielded (connect shield in control cabinet)  
Cable diameter: 4.5 ... 11 mm

## M12 plug-in connector port

### Connector on amplifier

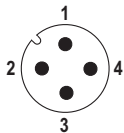

### Mating connector and wire colors with pre-assembled cable set

Please order the cable set separately, see page 3

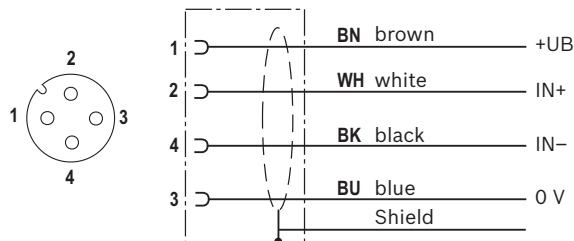

**The connection for the protective earthing conductor is not provided**

Connection cross-section:  
4 x 0.75 mm<sup>2</sup> shielded  
(connect shield in control cabinet)

**Adjustment elements / dimensions** (dimensions in mm)

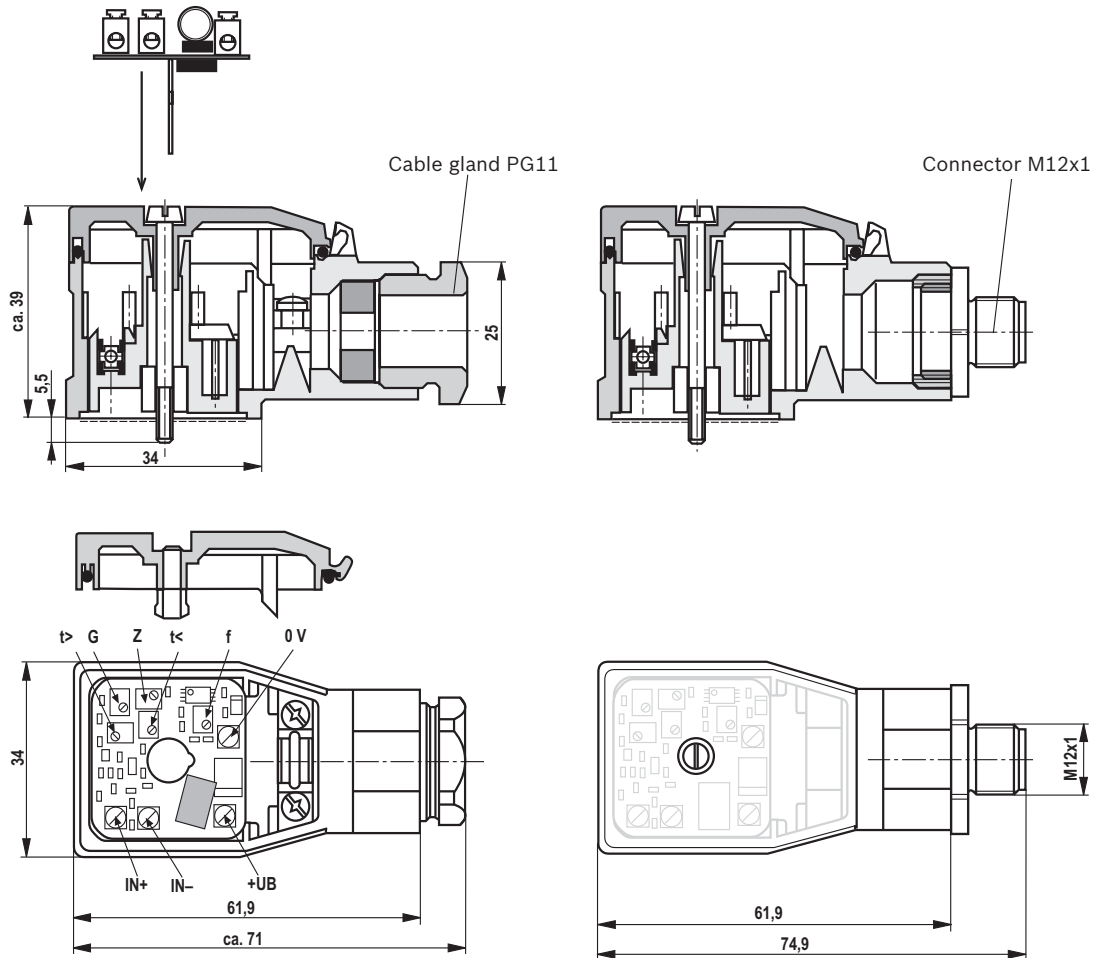

Top view on open housing:

- G Command value attenuator / maximum current
- Z Zero point potentiometer / pilot current
- t < Ramp time "up"
- t > Ramp time "down"
- f Frequency range

8/8 VT-SSPA1-1(5, 50, 100, 150) | Valve amplifier

## Project planning / maintenance instructions / additional information

- ▶ The plug insert can be rotated in 90° steps in compliance with ESD protective measures.
- ▶ The plug-in amplifier may only be wired when de-energized.
- ▶ Do not lay lines close to power cables!
- ▶ The distance to aerial lines, radios, and radar systems has to be 1 m at least.
- ▶ To set the potentiometers and to check the current values, use the measuring adapter and measure the currents in a potential-free manner.
- ▶ The specified maximum solenoid currents must not be exceeded.
- ▶ Do not use solenoids with integrated free-wheeling diodes.
- ▶ The supply voltage is to be protected by means of a fuse – see “Technical data”.

### Notice:

The solenoids are controlled with a clocked voltage. The solenoid voltage impulse level corresponds to the applied operating voltage ( $+U_B$ ).

Solenoids with integrated EMC protection circuit may only be used if the response voltage of the protection circuit - both, for positive and negative voltage - is greater than the actual operating voltage.

The specifications of the valve manufacturers are to be observed.

### Notice:

- ▶ With a strongly fluctuating operating voltage, it may in the individual case be necessary to use an external smoothing capacitor with a capacity of approx. 470  $\mu\text{F}$  to 2200  $\mu\text{F}$ .
- ▶ The line length should not exceed 50 m. For longer lines, a capacitor with  $C \geq 100 \mu\text{F}$  has to be connected between  $U_B$  and 0 V. The line between capacitor and plug-in amplifier must not be longer than 50 m.

Recommendation: Capacitor module VT 11110 (see data sheet 30750); sufficient for up to 5 plug-in amplifiers

© This document, as well as the data, specifications and other information set forth in it, are the exclusive property of Bosch Rexroth AG. It may not be reproduced or given to third parties without consent of Bosch Rexroth AG. The data specified above only serve to describe the product. No statements concerning a certain condition or suitability for a certain application can be derived from our information. The information given does not release the user from the obligation of own judgment and verification. It must be remembered that our products are subject to a natural process of wear and aging.

Bosch Rexroth AG, RE 30116, edition: 2014-04