

The Drive & Control Company

Rexroth
Bosch Group

2-way cartridge valve,
actively controllable

Type LC2A

RE 21040

Edition: 2013-06

Replaces: 11.10



- ▶ Size 16 ... 100
- ▶ Component series 1X
- ▶ Maximum operating pressure 420 bar
- ▶ Flow up to 12500 l/min ($\Delta p = 10$ bar)

Features

- ▶ Actively controllable 2/2 directional cartridge valve ("two-level active logics")
- ▶ Installation bore according to ISO 7368
- ▶ Functional diversity due to the installation of standard logic covers type LFA
- ▶ "Passive logic" function possible
- ▶ Variable assignment of the pilot oil channels to the active area
- ▶ Adjustment-free position switch type Q7
- ▶ Redundant spool position monitoring, optional
- ▶ Position signal open, optional
- ▶ Switching time-optimized check valve function, on request

Contents

Features	1
Ordering code	2 ... 4
Symbols	4
Assignment of the "active area"	5
Orifice assignment	5
Function, section	6
Technical data	7, 8
Characteristic curves	9 ... 12
Dimensions	13 ... 18
Installation bore	19, 20
Circuit examples	21 ... 23
Inductive position switch	24
Switching point behavior and overlap	24
Mating connectors for inductive position switch	25
More information	25

RE 21040, edition: 2013-06, **Bosch Rexroth AG**

2/26 LC2A | 2-way cartridge valve

Ordering code

01	02	03	04	05	06	07	08	09	10	11	12	13	14	15	16	17	18	19	20	21	22	23	
LC	2A					- 1X	/																*

01	Logic Cartridge	LC
02	2-level, active	2A
03	Size 16	016
	Size 25	025
	Size 32	032
	Size 40	040
	Size 50	050
	Size 63	063
	Size 80	080
	Size 100	100

Spool design (for area ratio see section on page 6)

04	$A_1 : A_2 = 2 : 1$ ($A_2 = 50\%$)	A
	$A_1 : A_2 = 14.3 : 1$ ($A_2 = 7\%$)	B
	$A_1 : A_2 = 1 : 0$ ($A_2 = 0\%$)	D
05	Without spring	00
	With spring, cracking pressure approx. 4 bar (relating to spool design "A")	40
06	Valve poppet without damping nose	E
	Valve poppet with damping nose	D
	Valve poppet with overlap	F
07	Component series 10 to 19 (10 to 19: Unchanged installation and connection dimensions)	1X

Active area ¹⁾ connected to port:

08	Z1	Z1
	Z2	Z2
	Z1 and Z2	U
	X	X
	Y	Y

Spool position monitoring ²⁾ (position switch 1 = "1"; position switch 2 = "2")

09	- Position monitoring "closed"	
	Without position switch (standard version; "1" can be retrofitted on side "Y")	no code
	With 1 position switch (standard version; "1" mounted on side "Y")	Q7
	With 2 position switches ("1" mounted on side "Y", installation side of "2" depending on size)	Q7Q7
	With 1 position switch and second installation bore (installation side of "1" depending on size, side of "2" is "Y")	Q.Q7
	Without position switch, with 2 installation bores (installation side of "1" is "Y", of "2" depending on size)	Q.Q.
	- Position monitoring "open" ³⁾	
	Without position switch (standard version; "1" can be retrofitted on side "Y")	Q.T
	With 1 position switch (standard version; "1" mounted on side "Y")	Q7T
	- Combined position monitoring "1" (closed) and "2" (open) ³⁾	
	With 2 position switches (installation side of "1" is "Y", side of "2" depending on size)	Q7Q7T
	Without position switch, with 2 installation bores (installation side of "1" is "Y", of "2" depending on size)	Q.Q.T
	With 1 position switch and second installation bore (installation side of "1" is "Y", side of "2" depending on size)	Q.Q7T
	- Position monitoring "closed"; NAMUR ⁴⁾	
	With 1 position switch (special version; "1" mounted on side "Y")	Q8
- Analog, position sensing		
Analog sensor, voltage output (additional information upon request)	Q9	

Bosch Rexroth AG, RE 21040, edition: 2013-06

Ordering code

01	02	03	04	05	06	07	08	09	10	11	12	13	14	15	16	17	18	19	20	21	22	23
LC	2A					-	1X	/														*

Electrical connection for position switch ⁵⁾

10	Without position switch	no code
	U _B = 24 V DC (standard; only with version "Q7")	G24
	U _B = 8 V DC (NAMUR; only with version "Q8")	G08

Pilot oil bore in the control spool ⁶⁾

11	Without pilot oil bore	no code
	- Pilot oil bore A → F (only size 25 to 100)	
	Size 25 – Maximum pilot oil bore Ø 10.0 mm	A100
	Size 32 – Maximum pilot oil bore Ø 13.0 mm	A130
	Size 40 – Maximum pilot oil bore Ø 16.0 mm	A160
	Size 50 – Maximum pilot oil bore Ø 20.0 mm	A200
	Size 63 – Maximum pilot oil bore Ø 26.0 mm	A260
	Size 80 – Maximum pilot oil bore Ø 32.0 mm	A320
	Size 100 – Maximum pilot oil bore Ø 40.0 mm	A400

12	Without orifice	no code
	With orifice in channel X – top	X**
13	Without orifice	no code
	With orifice in channel F – to the active area	F**
14	Without orifice	no code
	With orifice in channel Z1 – bottom (not with version "X" and "Y")	D**
15	Without orifice	no code
	With orifice in channel Z1 – top	Z**
16	Without orifice	no code
	With orifice in channel Y – top	Y**
17	Without orifice	no code
	With orifice in channel Z2 – bottom (not with version "X" and "Y")	S**
18	Without orifice	no code
	With orifice in channel Z2 – top	W**
19	Without orifice	no code
	With orifice in channel X – bottom (not with version "Z1", "Z2" and "U")	H**
20	Without orifice	no code
	With orifice in channel Y – bottom (not with version "Z1", "Z2" and "U")	L**

Corrosion resistance housing (outside)

21	None	no code
	Galvanic coating DIN 50979 – Fe//Zn8//Cr//TO (thick film passivation)	J50

Seal material ⁸⁾

22	FKM seals (other seals upon request)	F
23	Further details in the plain text	

Footnotes see page 4

4/26 LC2A | 2-way cartridge valve

Ordering code

- 1) Due to the construction, the active area (A₄) can always only be combined with one of the two pilot oil pairs "Z1/Z2" or "X/Y". Any subsequent change from "Z1/Z2" to "X/Y" is not possible.
- 2) Recommendation: Version "D" (valve poppet with damping nose); BG certificate only valid for this version (see page 24).
- 3) Not for sizes 16, 25 and 32.
- 4) Only with version "G08". Analysis electronics designed and approved of for NAMUR are commercially available.
- 5) Mating connectors, separate order, see page 25.
- 6) Only with type LC2A . D40E-1X/... for "check valve function"; the maximum pilot oil bore \varnothing has been determined depending on the size.
- 7) Order example: ** = dimension in mm x 10
– e.g. orifice \varnothing 1.2 mm in channel X – top = "X12"
or as blanking plug: Ordering code "99"
– e.g. blanking plug in channel Z2 – top = "W99"
- 8) The selection of the seal material depends on the operating parameters (fluid, temperature, etc.).

Symbols (1) = component side, (2) = plate side

Examples for spool forms and circuitries of the active area

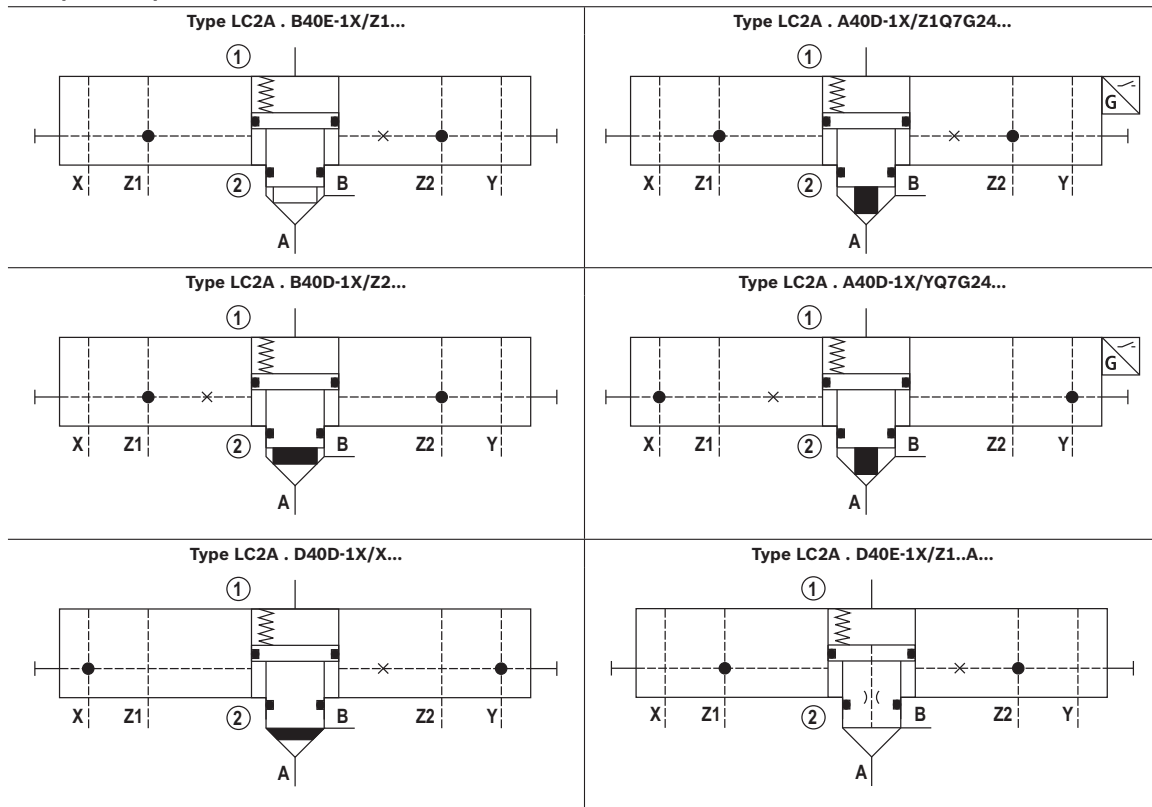

Bosch Rexroth AG, RE 21040, edition: 2013-06

Assignment of the "active area" A₄ (① = component side, ② = plate side)

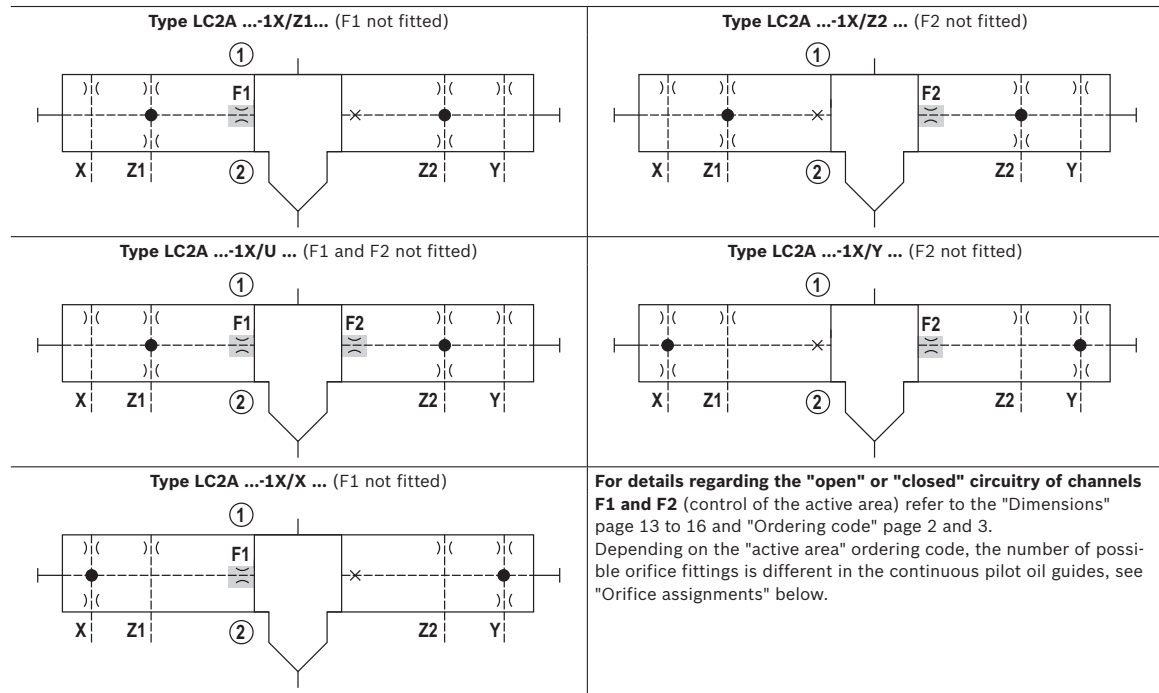

Orifice assignment (① = component side, ② = plate side)

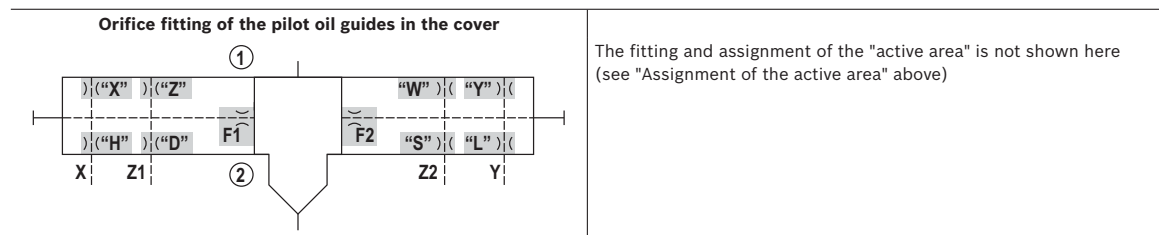

For details on the dimensions of the orifice installation bores "X" to "L", see "Dimensions" page 13 to 16.
On the component side, the orifice installation bores are always completely available; on the plate side, only the combinations of versions "H" and "L" or "D" and "S" are possible, see "Ordering code" page 2 and 3.

6/26 LC2A | 2-way cartridge valve

Function, section

General

The 2-way cartridge valves type LC2A (hereinafter referred to as "active logics" (2)) are designed as modular elements in compact block design and basically consist of cartridge (control spool (3) and socket (4)), the intermediate cover (5) as fixed functional unit and a control cover type LFA (1) that is part of the Rexroth standard logics program. This control cover (separate order, see data sheet 21010 or 21050) establishes the connection with the pilot control valves and/or other hydraulic elements and thus integrates the most different functions - irrespective of the basic assembly. Virtually all standard and special control covers type LFA can be mounted; thus, the active logics program can be limited to a few versions. Optionally, the active logics (2) is available with a position switch (6). By default, the "closed" position of the control spool (3) is recorded. The receiving hole for the position switch is provided as a standard. This means that the position switch "Q7" can be retrofitted at any time without requiring adjustments.

In contrast to the logic assemblies with only one control area in the spring chamber ("passive logics"), the name "active logics" significantly stands for a version with differential spool, with at least one additional control area A_4 ("two-level active logics"). This area allows for the opening

and keeping open of the active logics (2) by means of pilot pressure (without the necessity of pressure in the main ports A or B).

The spring chamber area A_5 of the control spool (3) consists of the individual areas $A_1 + A_2 + A_4$. Compared to passive logics without control area A_4 , this results in excess area which, with suitable hydraulic circuitry, offers advantages during closing and keeping closed (excessive force, closing velocity).

In general

$$\text{Area total } A_5 = A_1 + A_2 + A_4 = A_3 + A_4$$

The areas A_1 , A_2 and A_4 are effective in the opening direction, area A_5 (and the spring force) in closing direction. So the resulting effective force determines the position and movement of the control spool (3). Usually, there are no interim positions in the directional function versions. The direction of flow is free and can thus be perfectly adjusted to the application.

Active logics type LC2A are generally equipped with spool sealing and are therefore leakage-free inside. The seat area is hydraulically "tight".

Active logics for directional function

Depending on the task, different control spool versions are possible. The active area can be connected with the available pilot oil guides in almost any way and in this way, most different functions can be realized with only 1 basic assembly.

Installation bore

The active logics type LC2A can be directly installed in a standard installation bore according to ISO 7368 (see page 19). Thus, it is also suitable as retrofitting for existing "passive logics" that must be leakage-free inside or require position monitoring.

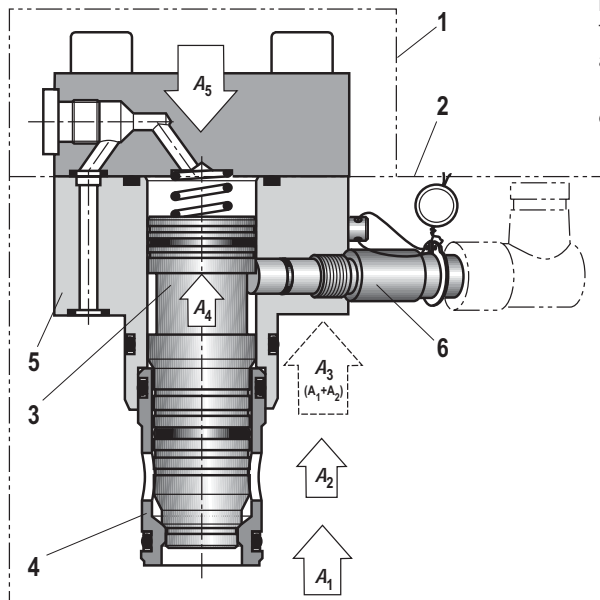

Type LC2A 025 ...-1X/.Q7G24... (with control cover type LFA . D... and monitoring of the closed position of the valve poppet)

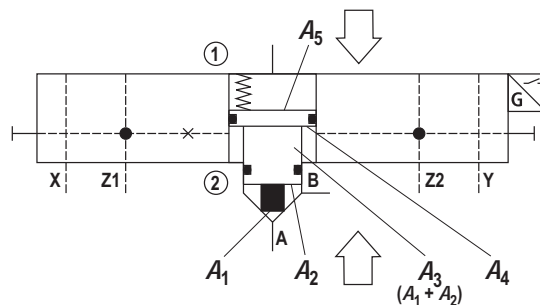

Technical data

(for applications outside these parameters, please consult us!)

general			
Ambient temperature range	°C	-20 ... +80	
MTTFd values according to EN ISO 13849	Years	150 (for further details see data sheet 08012)	
hydraulic			
Maximum operating pressure	bar	420 (500 bar on request)	
Maximum flow	l/min	12500 (for size 100, see characteristic curves page 9 and 11)	
Hydraulic fluid		See table below	
Hydraulic fluid temperature range (at the valve working ports)	°C	-20 ... +80	
Viscosity range	mm ² /s	2.8 ... 500	
Maximum admissible degree of contamination of the hydraulic fluid - cleanliness class according to ISO 4406 (c)		Class 20/18/15 ¹⁾	
Hydraulic fluid	Classification	Suitable sealing materials	Standards
Mineral oils	HL, HLP, HVLP	FKM, NBR ²⁾	DIN 51524
Bio-degradable	- insoluble in water	HETG	FKM, NBR ²⁾
	- soluble in water	HEES	FKM
	- water-free	HEPG	FKM
Flame-resistant	- containing water	HFDU, HFDR	ISO 12922
		HFC (Fuchs Hydrotherm 46M, Petrofer Ultra Safe 620)	NBR ²⁾



Important information on hydraulic fluids!

- ▶ For more information and data on the use of other hydraulic fluids refer to data sheet 90220 or contact us!
- ▶ There may be limitations regarding the technical valve data (temperature, pressure range, life cycle, maintenance intervals, etc.)!
- ▶ The flash point of the hydraulic fluid used must be 40 K higher than the maximum solenoid surface temperature.

▶ Flame-resistant – containing water:

- Maximum pressure difference per control edge 175 bar
- Pressure pre-loading at the tank port >20% of the pressure differential, otherwise increased cavitation
- Life cycle as compared to operation with mineral oil HL, HLP 50 to 100%

¹⁾ The cleanliness classes specified for the components must be adhered to in hydraulic systems. Effective filtration prevents faults and at the same time increases the life cycle of the components. For the selection of the filters see www.boschrexroth.com/filter.

²⁾ Upon request

8/26 LC2A | 2-way cartridge valve

Technical data

(for applications outside these parameters, please consult us!)

Size of the annulus area

Area in cm ²	Type	Size							
		16	25	32	40	50	63	80	100
A ₁	LC2A . A...	1.89	4.26	6.79	11.1	19.63	30.2	37.9	63.6
	LC2A . B...	2.66	5.73	9.51	15.55	26.42	41.28	52.8	89.1
	LC2A . D...	2.84	6.16	10.18	16.62	28.27	44.2	56.74	95.0
A ₂	LC2A . A...	0.95	1.89	3.39	5.52	8.64	14.0	18.84	31.4
	LC2A . B...	0.18	0.43	0.67	1.07	1.85	2.90	3.94	5.9
	LC2A . D...	–	–	–	–	–	–	–	–
A ₃	LC2A . A/B/D...	2.84	6.16	10.18	16.62	28.27	44.2	56.74	95.0
A ₄		0.62	1.39	2.39	3.81	5.94	8.75	11.2	19.1
A ₅		3.46	7.55	12.6	20.4	34.2	52.8	67.9	114.0
Area ratio A ₅ : A ₄ ³⁾		5.58	5.43	5.27	5.35	5.76	6.03	6.06	5.92

- ³⁾ When determining the orifice diameters for influencing the switching time, please observe the area ratio A₅ : A₄ (inflowing and outflowing hydraulic fluid in the control chambers A₅ and A₄)
In case of non-compliance there may be pressure pressure intensification!

Spool form (damping nose)

	Type	Size								
		16	25	32	40	50	63	80	100	
Stroke	cm	LC2A . ..E...	0.9	1.17	1.4	1.7	2.1	2.3	2.4	3.0
		LC2A . ..D...	0.9	1.17	1.4	1.9	2.3	2.8	3.0	3.8
		LC2A . ..F...	0.9	1.17	1.4	1.9	2.3	2.8	3.0	3.8
Pilot volume	cm ³	LC2A . ..E...	3.1	8.8	17.6	34.7	71.8	121.4	163.0	339.0
		LC2A . ..D...	3.1	8.8	17.6	38.8	78.7	147.8	203.7	429.4
		LC2A . ..F...	3.1	8.8	17.6	38.8	78.7	147.8	203.7	429.4
Theoretical pilot flow ⁴⁾	l/min	LC2A . ..E...	3.7	10.6	21.1	41.6	86.6	145.7	195.6	406.8
		LC2A . ..D...	3.7	10.6	21.1	46.6	94.4	177.4	244.4	515.3
		LC2A . ..F...	3.7	10.6	21.1	46.6	94.4	177.4	244.4	515.3
Weight	kg	LC2A ...	2.2	2.6	3.9	10.3	16.5	30.5	52.5	92.0

Cracking pressure in bar

Direction of flow A to B ⁵⁾	LC2A . A...	3.50	3.90	3.80	4.0	4.11	3.8	3.13	3.04
	LC2A . B...	2.48	2.90	2.70	2.86	3.05	2.8	2.25	2.17
Direction of flow B to A ⁵⁾	LC2A . A...	6.96	8.74	7.6	8.05	9.34	8.15	6.3	6.2
	LC2A . B...	36.6	38.3	38.6	41.5	43.6	39.4	30.2	32.5
Control open with active area	Version "40"	> 30							
	Without spring	> 12							

- ⁴⁾ Quantity indications refer to a theoretical switching time of $t = 50$ ms (control chamber A₅)
⁵⁾ With direction of flow B → A, the control spool version "D" ("0%") has no immediately effective control open area (A₂ = 0). For this direction of flow, the active area is to be controlled. We recommend a minimum pressure of 30 bar. The cracking pressure of the control spool version "D" almost corresponds to version "B" (A → B)

Bosch Rexroth AG, RE 21040, edition: 2013-06

Characteristic curves: Without damping nose "E"
(measured with HLP46, $\vartheta_{oil} = 40 \pm 5 \text{ }^\circ\text{C}$ [$104 \pm 9 \text{ }^\circ\text{F}$])

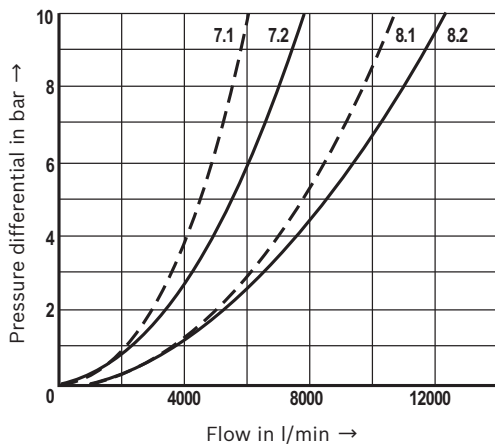
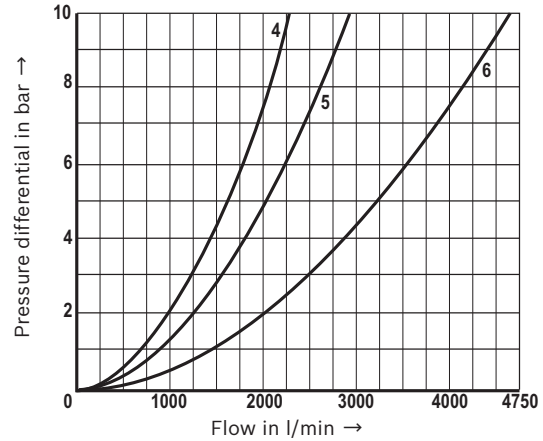
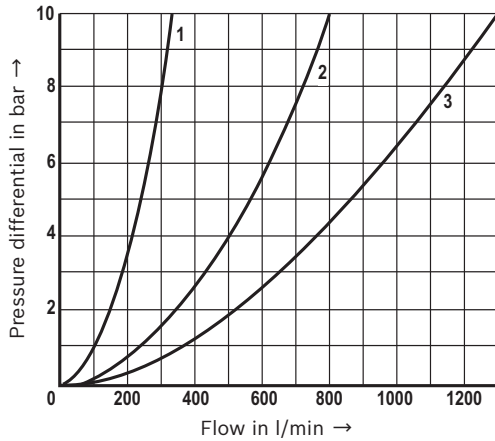

- 1 Size 16
- 2 Size 25
- 3 Size 32
- 4 Size 40
- 5 Size 50
- 6 Size 63
- 7.1 Size 80, spool design "A"
- 7.2 Size 80, spool design "B" and "D"
- 8.1 Size 100, spool design "A"
- 8.2 Size 100, spool design "B" and "D"

Notice!

The indicated characteristic curves have been determined without inserted springs and show average values with regard to the two possible directions of flow.

10/26 LC2A | 2-way cartridge valve

Characteristic curves: With damping nose "D"
(measured with HLP46, $\vartheta_{oil} = 40 \pm 5 \text{ }^\circ\text{C}$ [$104 \pm 9 \text{ }^\circ\text{F}$])

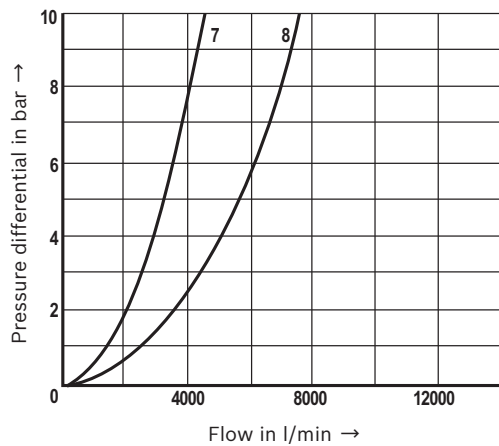
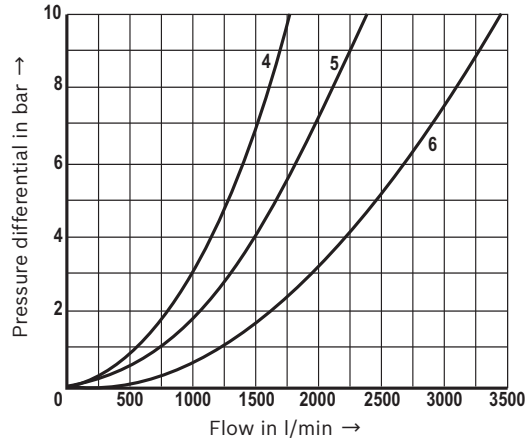
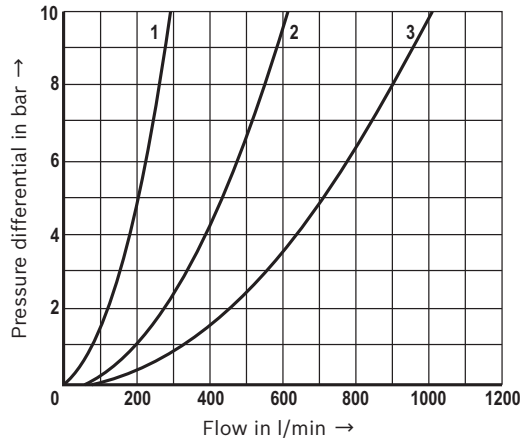

- 1 Size 16
- 2 Size 25
- 3 Size 32
- 4 Size 40
- 5 Size 50
- 6 Size 63
- 7 Size 80
- 8 Size 100



Notice!

The indicated characteristic curves have been determined without inserted springs and show average values with regard to the two possible directions of flow.

Bosch Rexroth AG, RE 21040, edition: 2013-06

Characteristic curves: With overlap "F"
(measured with HLP46, $\vartheta_{oil} = 40 \pm 5 \text{ }^\circ\text{C}$ [$104 \pm 9 \text{ }^\circ\text{F}$])

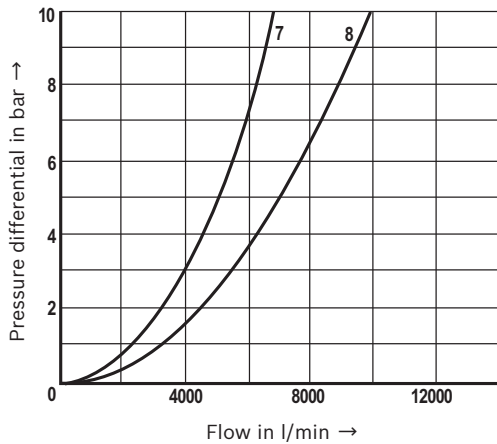
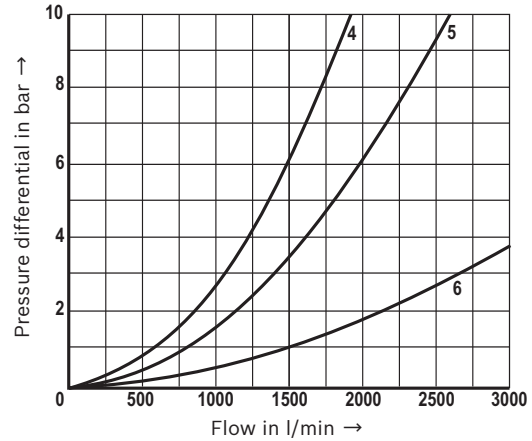
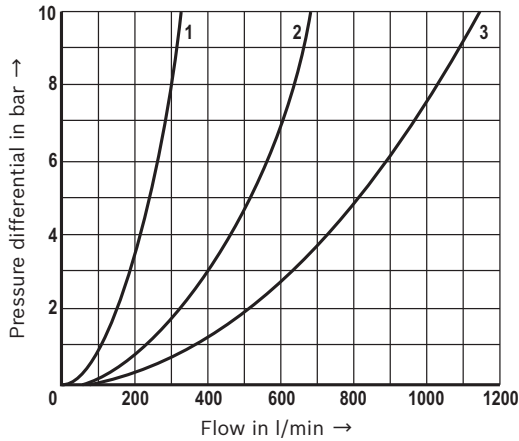

- 1 Size 16
- 2 Size 25
- 3 Size 32
- 4 Size 40
- 5 Size 50
- 6 Size 63
- 7 Size 80
- 8 Size 100

Notice!

The indicated characteristic curves have been determined without inserted springs and refer to the direction of flow A → B.

12/26 LC2A | 2-way cartridge valve

Characteristic curves for selecting the orifices

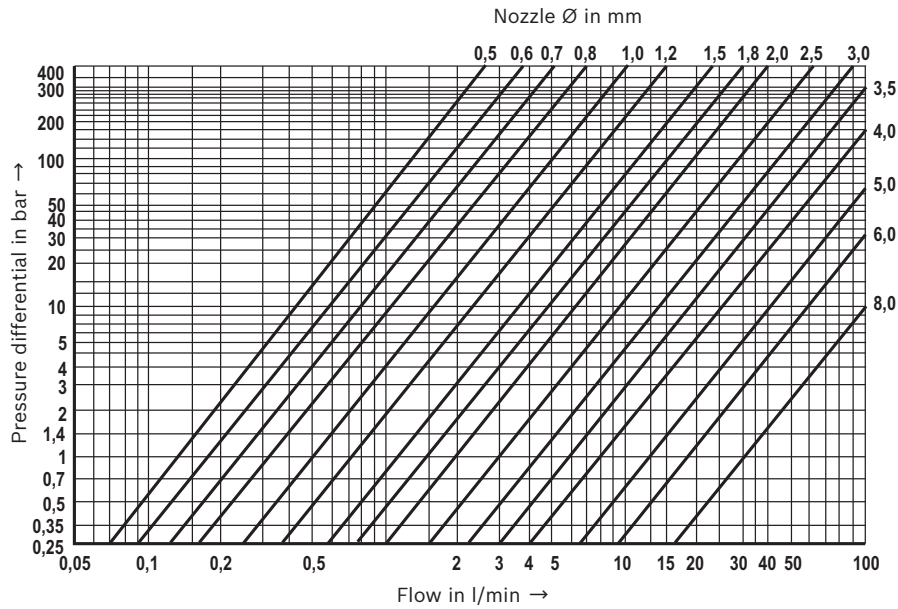

Orifice Ø in mm	Material number				
	M6 conical	M8 x 1 conical	G1/8	G1/4	G1/2
0.5	R900157933	R900157930	R900164240	R913000879	-
0.6	R900157934	R900149430	R900159145	R900756301	-
0.7	R900157931	R900143957	R901082918	-	-
0.8	R900152276	R900136843	R900144212	R900153856	R900691565
1.0	R900149335	R900136842	R900135607	R900147884	R900139115
1.2	R900152286	R900139101	R900146270	R900153868	R900150714
1.5	R900148823	R900133712	R900144910	R900144911	R900139117
1.8	R900157932	R900150953	R900142840	R900159108	R900159026
2.0	R900156650	R900137299	R900155897	R900147890	R900148352
2.5	R900157929	R900137445	R900148351	R900165178	R900148353
3.0	R900181894	R900144761	R900111282	R900153866	R900148361
3.5	-	R900136079	R900688752	R900684311	R913019857
4.0	-	R900802480	R900178466	R900155898	R900149939
5.0	-	-	R900167529	R900141422	R900143775
6.0	-	-	-	-	R900147875
8.0	-	-	-	-	R900159028
Plug screw (ordering code "99")	R900023986	R900003443	R900006324	R900003455	R900006445

Bosch Rexroth AG, RE 21040, edition: 2013-06

14/26 LC2A | 2-way cartridge valve

Dimensions: Size 16 ... 32
(dimensions in mm)

With spool position monitoring (2 position switches "Q7", position monitoring "closed")

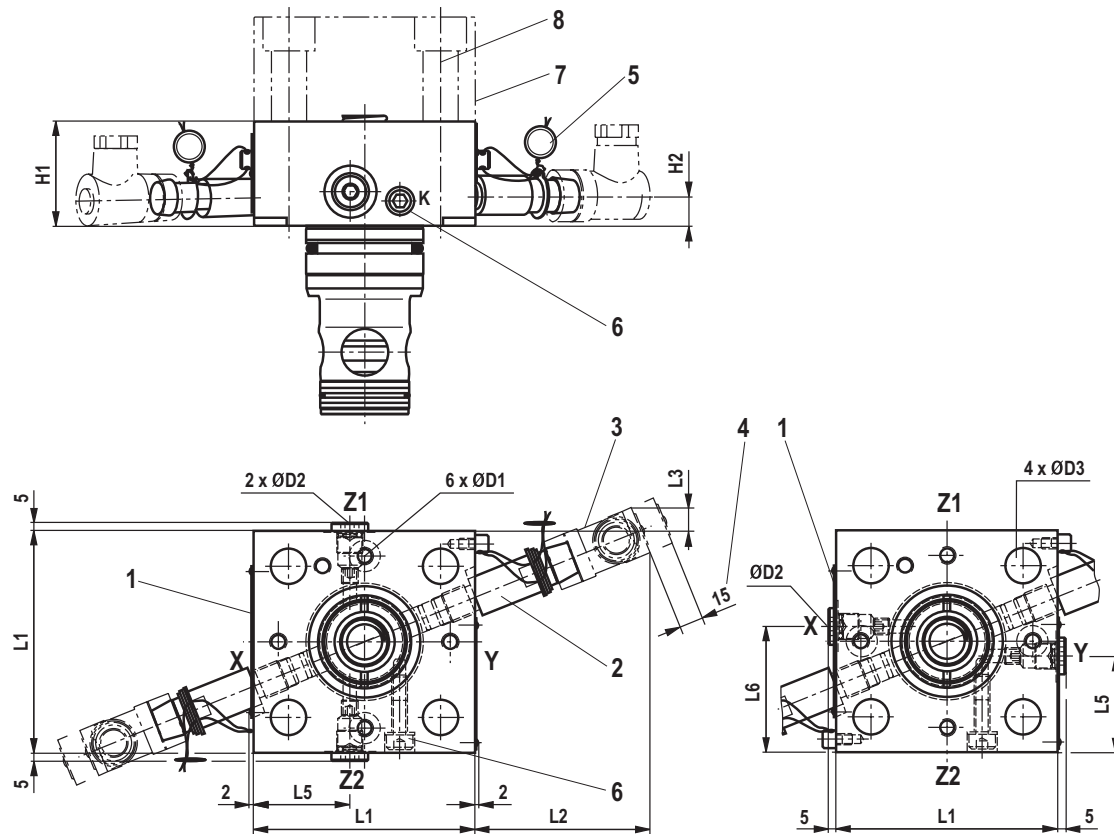

View: Version "Z1", "Z2" or "U"

View: Version "X" or "Y"

Size	16	25	32
L1	80	85	100
L2	67	67	65
L3	15	9.5	2
L5	34.5	37	45
L6	45.5	48	55
H1	40	40	50
H2 ¹⁾	11.5	11.5	13.5
H2 ²⁾	11.5	11.5	13.5
ØD1	M6	M6	M8 x 1
ØD2	G1/8	G1/8	G1/8
ØD3	8.5	13.5	19

¹⁾ Position monitoring "closed"

²⁾ Position monitoring "open"

Item explanations see page 18.

Bosch Rexroth AG, RE 21040, edition: 2013-06

Dimensions: Size 40 ... 63
(dimensions in mm)

With spool position monitoring (2 position switch "Q7")

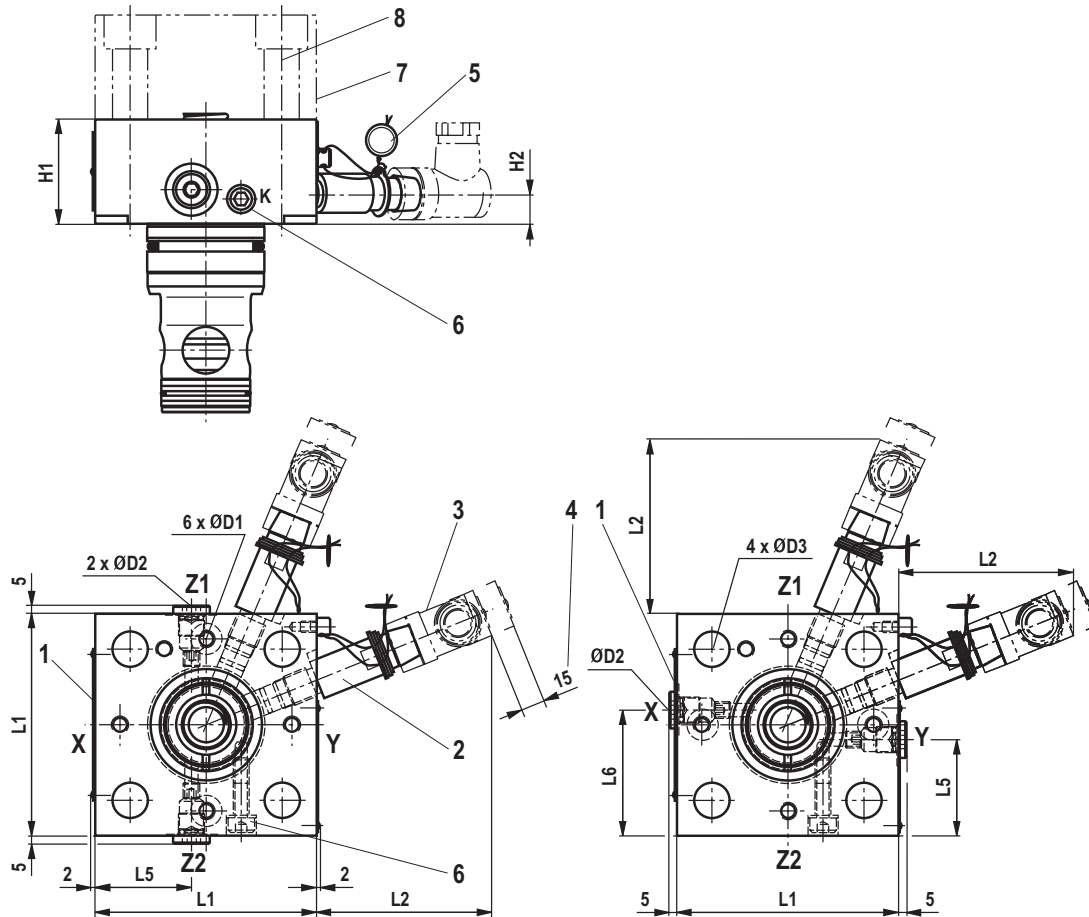

View: Version "Z1", "Z2" or "U"

View: Version "X" or "Y"

Size	40	50	63
L1	125	140	180
L2	58	58	45
L5	56	63.5	82.5
L6	69	63.5	82
H1	80	100	110
H2 ¹⁾	29.5	42.5	45.5
H2 ²⁾	23	35	36
ØD1	G1/8	G1/8	G1/4
ØD2	G1/4	G1/4	G3/8
ØD3	22	24	26 ⁺¹

¹⁾ Position monitoring "closed"

²⁾ Position monitoring "open"

Item explanations see page 18.

16/26 LC2A | 2-way cartridge valve

Dimensions: Size 80 ... 100
(dimensions in mm)

With spool position monitoring (1 position switch "Q7")

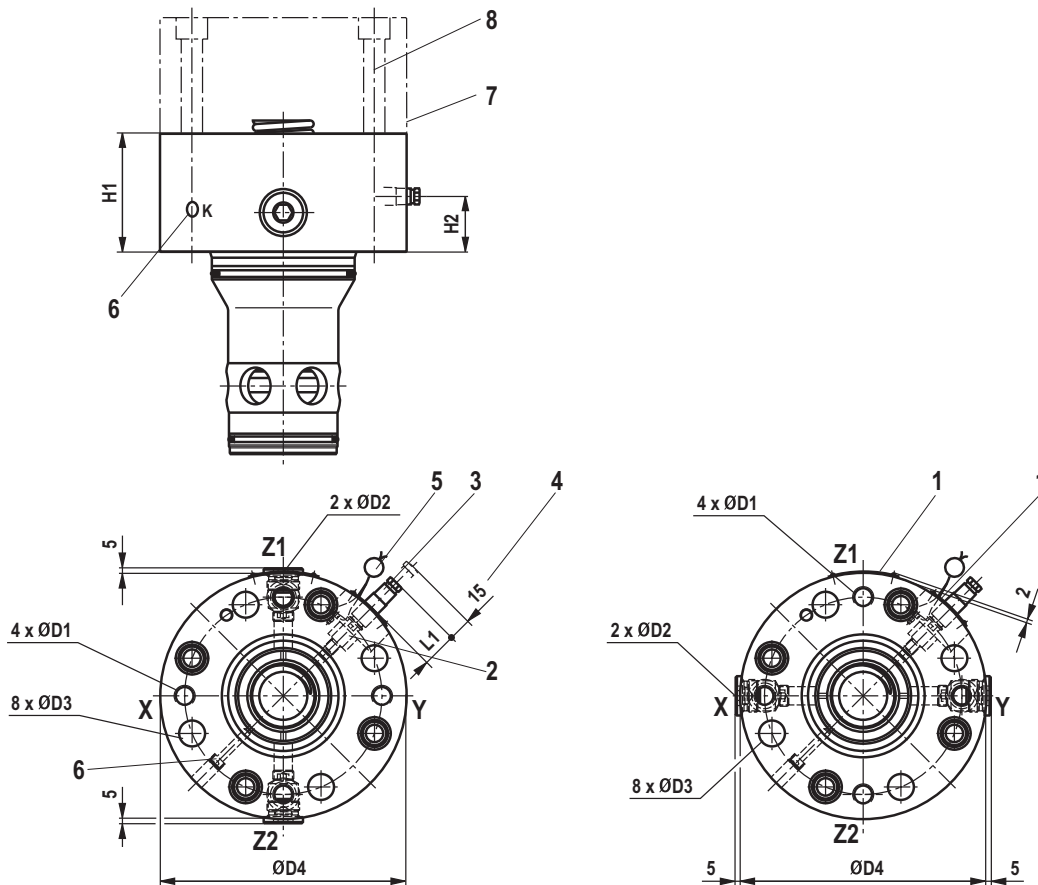

View: Version "Z1", "Z2" or "U"

View: Version "X" or "Y"

Size	80	100
ØD1	G1/2	G1/2
ØD2	G1	G1
ØD3	26 ⁺¹	33 ^{+0.5}
ØD4	250	300
L1	37	26
H1	120	140
H2 ¹⁾	48	55.2
H2 ²⁾	37.5	44.7

¹⁾ Position monitoring "closed"

²⁾ Position monitoring "open"

Item explanations see page 18.

Dimensions: Size 80 ... 100
(dimensions in mm)

With spool position monitoring (2 position switch "Q7")

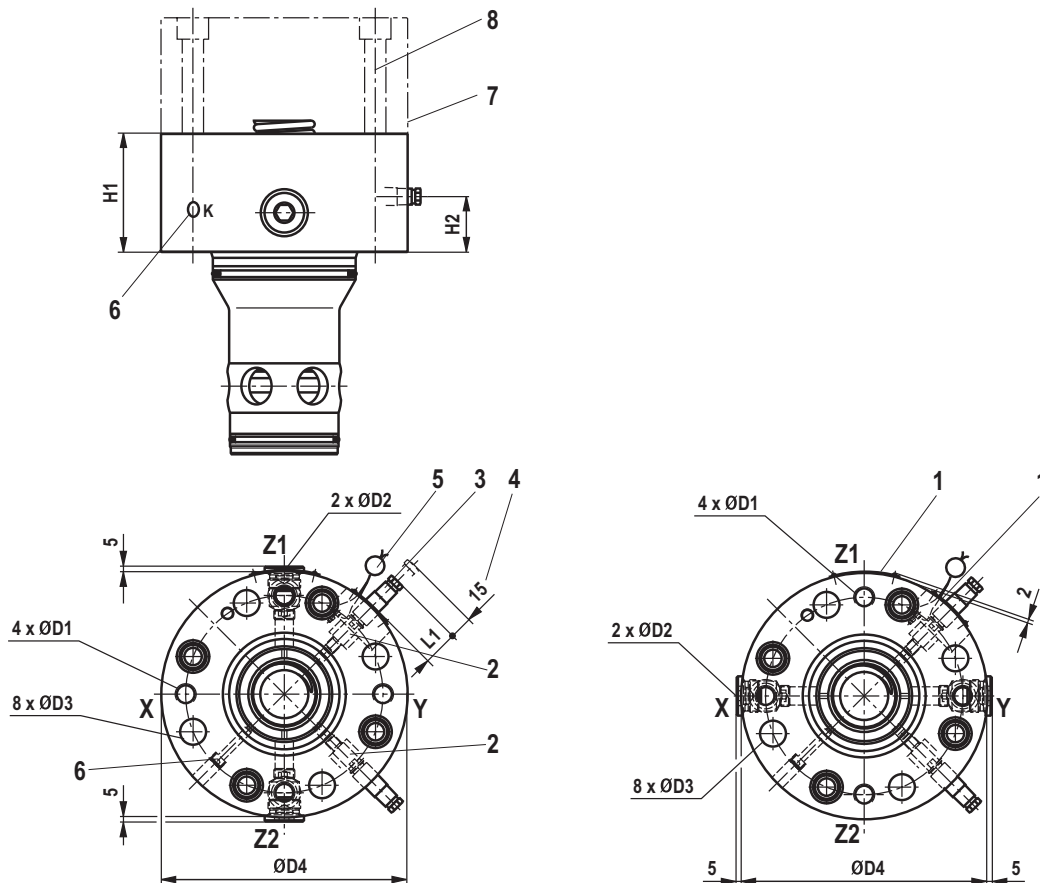

View: Version "Z1" or "Z2"

View: Version "X" or "Y"

Size	80	100
ØD1	G1/2	G1/2
ØD2	G1	G1
ØD3	26 ⁺¹	33 ^{+0.5}
ØD4	250	300
L1	37	26
H1	120	140
H2 ¹⁾	48	55.2
H2 ²⁾	37.3	44.7

¹⁾ Position monitoring "closed"

²⁾ Position monitoring "open"

Item explanations see page 18.

18/26 LC2A | 2-way cartridge valve

Dimensions

- 1 Name plate
- 2 Position switch (optional) or blind plug
- 3 Mating connector (separate order, see page 25)
- 4 Space required for removing the mating connector
- 5 Sealing by the factory
- 6 Transport lock for control spool (identification K). **Don not remove! Only loosen or disassemble and assemble for service/repair purposes!**
- 7 Standard end/control cover type LFA... (separate order, depends on the basic hydraulic function)
- 8 Valve mounting screws (separate order, see table below)

Valve mounting screws (separate order)

Size	Control cover type LFA	Quantity	Hexagon socket head cap screws ISO 4762 - 10.9-flZn-240h-L		
			Dimension	Material number	Tightening torque M_A ²⁾ in Nm $\pm 10\%$
16	WE., GW.	4	M8 x 85	R913004145	30
	WEM.		M8 x 110	R913000260	
	¹⁾		M8 x 80	R913000276	
25	HWM.	4	M12 x 140	R913000312	100
	¹⁾		M12 x 90	R913000473	
32	H1, H2	4	M16 x 130	R913000636	240
	H3, H4		M16 x 120	R913000594	
	HWM.		M16 x 160	R913000354	
	¹⁾		M16 x 110	R913000079	
40	H1, H2, HWM.	4	M20 x 190	R913001911	480
	¹⁾		M20 x 150	R913000385	
50	H2, H4, HWM.	4	M20 x 220	R913001910	480
	¹⁾		M20 x 180	R913004960	
63	H2, H4, HWM.	4	M30 x 260	R913015758	1600
	¹⁾		M30 x 210	R913000491	
80	H2, H4	8	M24 x 240	R913004973	800
	²⁾		M24 x 220	R913000195	
100	D, WE.	8	M30 x 260	R913015758	1600
	¹⁾		M30 x 280	R913015760	

¹⁾ More available series control covers

²⁾ Calculated with total friction coefficient $\mu = 0.09$ to 0.14 , adjust in case of modified surfaces

Notice!

The length of the valve mounting screws of the active logics (intermediate cover) must be selected according to the related control cover type LFA....

Screw type, screw length and tightening torque are to be adjusted to the conditions depending on the application. For reasons of stability, exclusively the above valve mounting screws may be used.

Installation bore and connection dimensions according to DIN ISO 7368 (dimensions in mm)

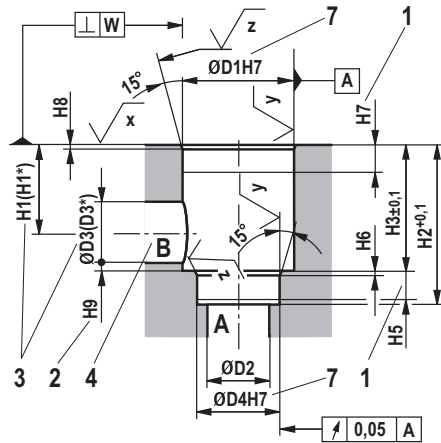

$$\sqrt{x} = \sqrt{Rz1max 4}$$

$$\sqrt{y} = \sqrt{Rz1max 8}$$

$$\sqrt{z} = \sqrt{0,0025 - / Pt max 16}$$

Size 16 ... 63

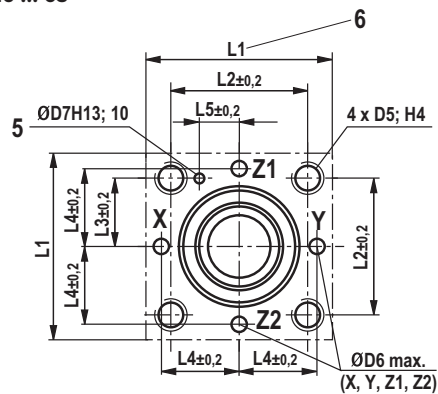

Size 80 and 100

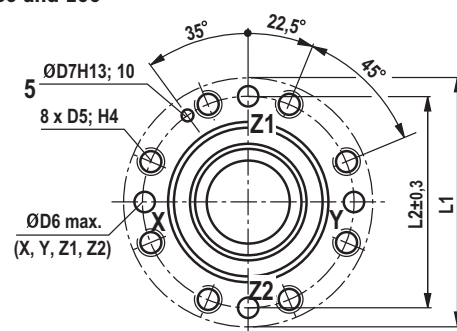

- 1 Depth of fit
- 2 Control dimension
- 3 With a different diameter ØD3 or ØD3^* , the distance $H1$ or $H1^*$ has to be adjusted.
- 4 Port B can be positioned around the central axis of port A. However, it must be observed that the mounting bores and the pilot oil bores are not damaged.
- 5 Bore for locking pin
- 6 With size 16 to 32, fit H8 is admissible!



Notice!

All the information on the mounting bore D5 is based on the use of hexagon socket head cap screws according to ISO 4762.

Dimensions see page 20.

20/26 LC2A | 2-way cartridge valve

Installation bore and connection dimensions according to DIN ISO 7368 (dimensions in mm)

Size	16	25	32	40	50	63	80	100
ØD1	32	45	60	75	90	120	145	180
ØD2	16	25	32	40	50	63	80	100
ØD3	16	25	32	40	50	63	80	100
ØD3*¹⁾	25	32	40	50	63	80	100	125
ØD4	25	34	45	55	68	90	110	135
ØD5	M8	M12	M16	M20	M20	M30	M24	M30
ØD6²⁾	4	6	8	10	10	12	16	20
ØD7	4	6	6	6	8	8	10	10
H1	34	44	52	64	72	95	130	155
H1*¹⁾	29.5	40.5	48	59	65.5	86.5	120	142
H2	56	72	85	105	122	155	205	245
H3	43	58	70	87	100	130	175 ^{+0.2}	210 ^{+0.2}
H4	20	25	35	45	45	65	50	63
H5	11	12	13	15	17	20	25	29
H6	2	2.5	2.5	3	3	4	5	5
H7	20	30	30	30	35	40	40	50
H8	2	2.5	2.5	3	4	4	5	5
H9	0.5	1	1.5	2.5	2.5	3	4.5	4.5
L1	80	85	102	125	140	180	250	300
L2	46	58	70	85	100	125	200	245
L3	23	29	35	42.5	50	62.5	-	-
L4	25	33	41	50	58	75	-	-
L5	10.5	16	17	23	30	38	-	-
W	0.05	0.05	0.1	0.1	0.1	0.2	0.2	0.2

¹⁾ Dimension ØD3* refers to dimension H1*

²⁾ Maximum dimension

Circuit examples (function must be checked with the application)

Check valve, releasable

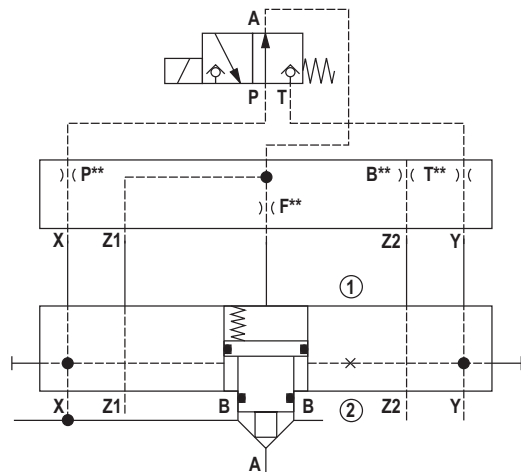

Type M-3SEW 6 U../420..

Type LFA . WEMA...

Type LC2A . A40E-1X/X...

"Closing pressure-supported by excess area" function (e.g. with control cover type "D")

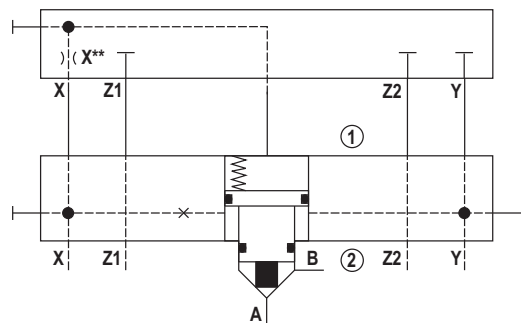

Type LFA . D...

Type LC2A . A40D-1X/Y...

"Passive logics with piston seal and spool position monitoring" function (closing with spring force without excess area; here with control cover type "D"); ideal for the retrofitting of existing circuits

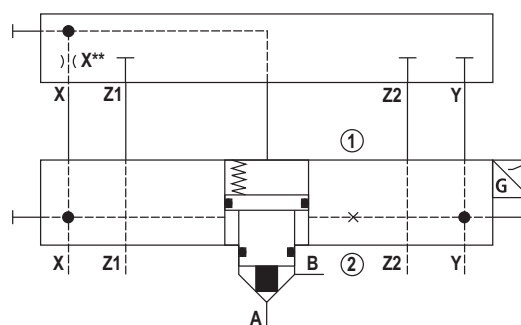

Type LFA . D...

Type LC2A . A40D-1X/XQ7...

22/26 LC2A | 2-way cartridge valve

Circuit examples (function must be checked with the application)

"Self-closing" or "open basic position" (e.g. with control cover type "WEMA")

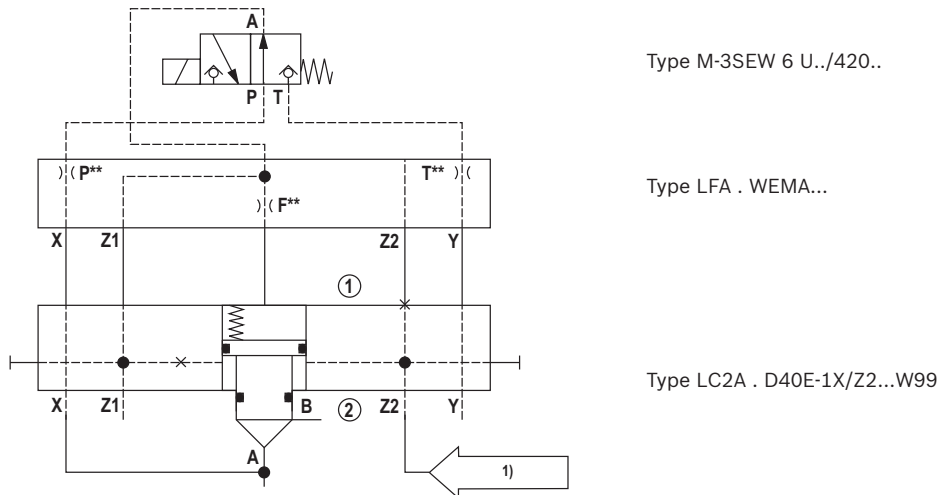

Control spool remains open as long as $F_{Z2} \geq F_A + \text{spring force}$
In case of failure or drop of the pilot pressure, the logic element closes hydraulically. Irrespective thereof, the logic element can be opened by unloading the spring chamber (minimum pilot pressure required).

"Pulling" function and safe keeping closed

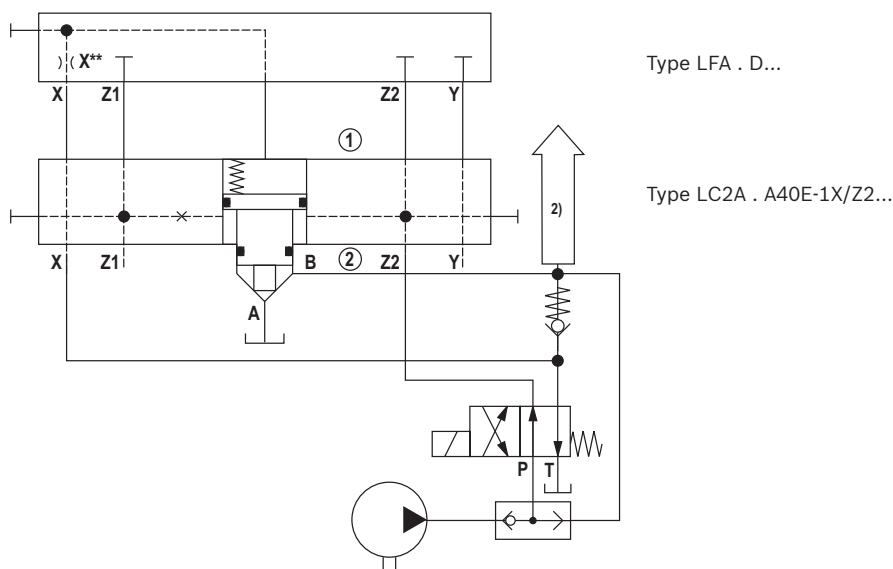

The control spool of the active logics can be opened or closed depending on the two pilot oil pressures X and Z2. Thus, free flow is possible in both directions, irrespective of the pressure level in port B.

- 1) Pilot pressure
- 2) Actuator

Bosch Rexroth AG, RE 21040, edition: 2013-06

Circuit examples (function must be checked with the application)

"Passive logics with spool sealing" function, spool position monitoring and stroke limitation

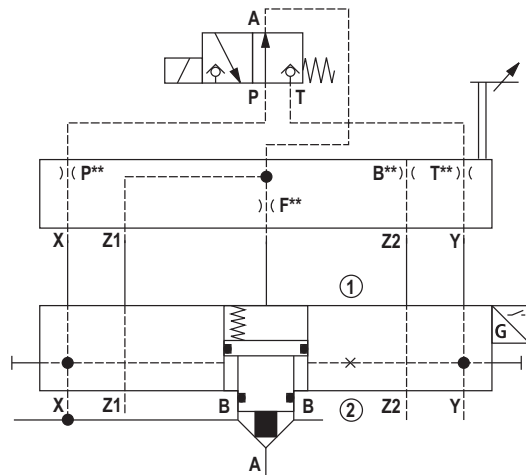

Type M-3SEW 6 U../420..

Type LFA . HWMA...

Type LC2A . A40D-1X/XQ7...

"Closed basic position" function; safe keeping closed with maximum pilot pressure

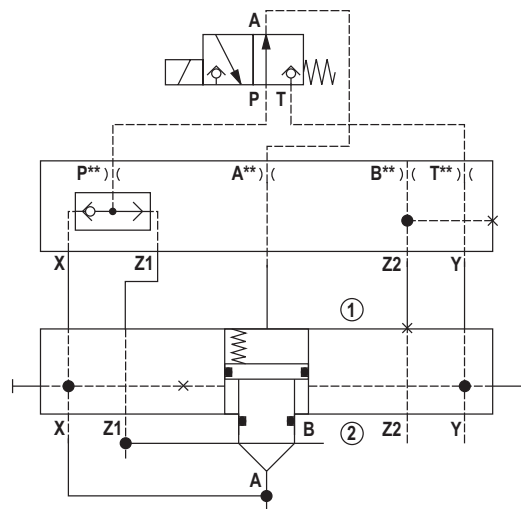

Type M-3SEW 6 U../420..

Type LFA . GWMA...

Type LC2A . D40E-1X/Y... (W99)

24/26 LC2A | 2-way cartridge valve

Inductive position switch type Q7, electrical connection

The electrical connection is realized via a 4-pole mating connector with connection thread M12 x 1 (separate order, see page 25)

Operating voltage Direct voltage 12 to 30 V
(residual ripple <15%)

Load capacity of the outputs: 200 mA; short-circuit-proof

Contact assignment:

1:	+U _B
2:	Normally closed contact
3:	L0
4:	Normally open contact

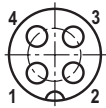

Tightening torque: $M_A = 10^{+5}$ Nm

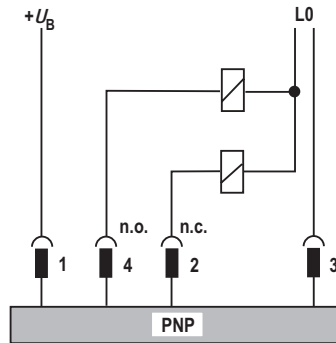

The inductive position switch type Q7 can be connected as normally closed or normally open contact.

Notice!

- ▶ The "closed" spool position is adjusted to and optimized for a condition at operating temperature. Considerably deviating operating temperatures thus influence the absolute switching position as well as its hysteresis.
- ▶ Attention! The position switch type Q7 has no connection for the protective earthing conductor!
- ▶ Assembly tool for position switch type Q7 or blind plug upon request.
- ▶ **BG certificate**
The respectively valid "MHHW 10014" certificate for using the active logics type LC2A with position switch type Q7 in hydraulic security locks in injection molding machines according to the manufacturer's installation instructions is available upon request.

Switching point behavior and overlap: Valve poppet with damping nose "D" or overlap nose "F" and position overlap "closed"

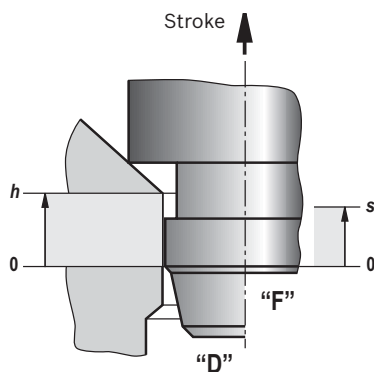

h Overlap stroke (mechanical)
s Switching point window (electrical)
q_{v0} Maximum flow until **h_{min}**

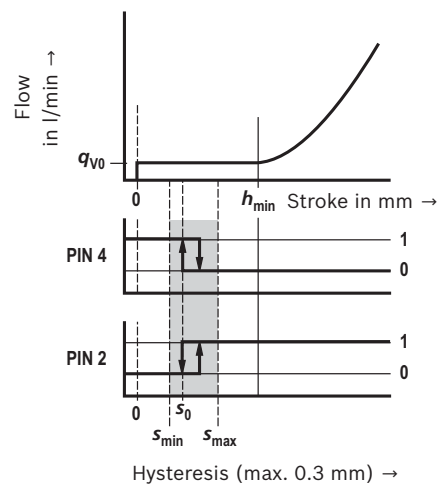

Bosch Rexroth AG, RE 21040, edition: 2013-06

2-way cartridge valve | **LC2A** 25/26

Mating connectors for inductive position switch (dimensions in mm)

Mating connector suitable for K24 4-pole, M12 x 1 with screw connection, cable gland Pg 9.

Material no. **R900031155**

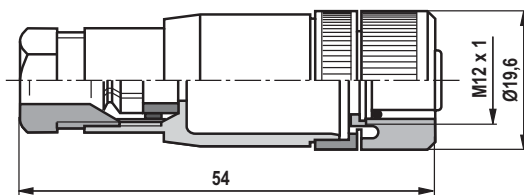

Mating connector suitable for K24 4-pole (only up to size 80), M12 x 1 with screw connection, cable gland Pg 9, angled. Housing can be rotated by 4 x 90° in relation to the contact insert.

Material no. **R900082899**

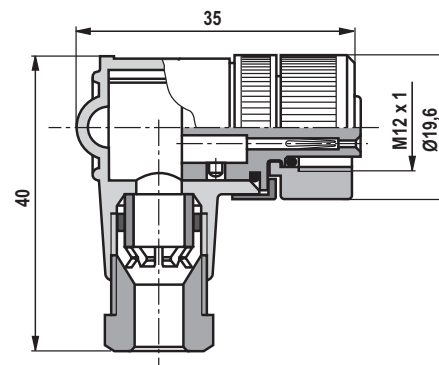

For more information refer to data sheet **08006**.

More information

- ▶ Passive logics (directional function)
- ▶ Passive logics (pressure function)
- ▶ Mineral oil-based hydraulic fluids
- ▶ Reliability characteristics according to EN ISO 13849
- ▶ General product information on hydraulic products
- ▶ Installation, commissioning and maintenance of industrial valves
- ▶ Hydraulic valves for industrial applications
- ▶ Selection of the filters
- ▶ Production of logistic bores

Data sheet 21010
Data sheet 21050
Data sheet 90220
Data sheet 08012
Data sheet 07008
Data sheet 07300
Data sheet 07600-B
www.boschrexroth.com/filter
On request

RE 21040, edition: 2013-06, **Bosch Rexroth AG**

26/26

Notes

© This document, as well as the data, specifications and other information set forth in it, are the exclusive property of Bosch Rexroth AG. It may not be reproduced or given to third parties without its consent.
The data specified above only serve to describe the product. No statements concerning a certain condition or suitability for a certain application can be derived from our information. The information given does not release the user from the obligation of own judgment and verification. It must be remembered that our products are subject to a natural process of wear and aging.

Bosch Rexroth AG, RE 21040, edition: 2013-06