

Electric Drives
and Controls

Hydraulics

Linear Motion and
Assembly Technologies

Pneumatics

Service

Rexroth
Bosch Group

Pressure sequence valve, direct operated

RE 26091/12.09

1/8

Type ZDZ

Size 10
Component series 5X
Maximum operating pressure 210 bar
Maximum flow 80 l/min

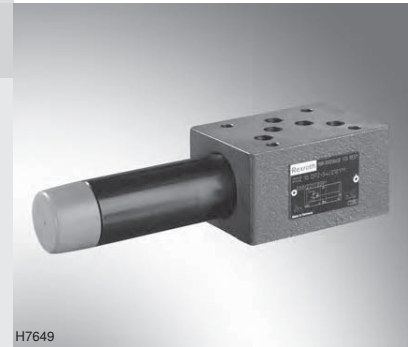

Table of contents

Content
Features
Ordering code
Symbols
Function, section
Technical data
Characteristic curves
Unit dimensions

Features

Page	
	– Sandwich plate valve
1	– Porting pattern according to ISO 4401-05-04-0-05
2	– Subplates see data sheet RE 45054 (separate order)
2	– 4 pressure ratings
3	– 4 adjustment types, optionally:
4	• Rotary knob
5	• Threaded pin with hexagon and protective cap
5	• Lockable rotary knob with scale
6	• Rotary knob with scale
	– With pressure gauge connection

Ordering code

Z	DZ	10	D		-5X/	Y	M	*	
Sandwich plate valve		Pressure sequence valve		Size 10 = 10		Direct operated = D		Pressure reduction in channel A (pilot oil from channel A①) = A	
Pressure reduction in channel A (pilot oil from channel A②) = C		Pressure reduction in channel P = P		Adjustment type		Rotary knob = 1		Threaded pin with hexagon and protective cap = 2	
Lockable rotary knob with scale ¹⁾ = 3		Rotary knob with scale = 7		Component series 50 to 59 (50 to 59: unchanged installation and connection dimensions) = 5X		no code =		Further details in the plain text	
V =		M =		Y =		Seal material		NBR seals	
								FKM seals	
								(other seals at request)	
								Attention!	
								Observe compatibility of seals with hydraulic fluid used!	
								without check valve	
								Pilot oil supply internal, pilot oil return external	
								Pressure rating	
								25 = Maximum sequencing pressure 25 bar	
								75 = Maximum sequencing pressure 75 bar	
								150 = Maximum sequencing pressure 150 bar	
								210 = Maximum sequencing pressure 210 bar	

¹⁾ H-key with material no. **R900008158** is included in the delivery.

Symbols (① = component side, ② = plate side)

Version "A"

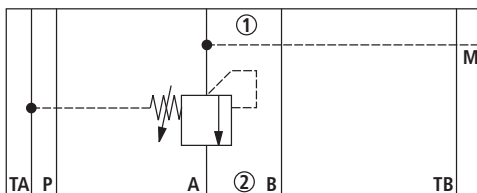

Version "P"

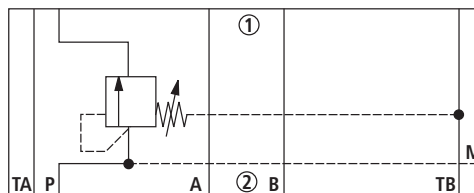

Version "C"

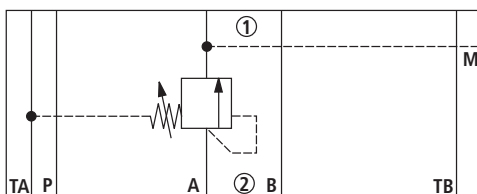

Function, section

The valve type ZDZ is a direct operated pressure sequence valve in sandwich plate design. It is used for the pressure-dependent sequencing of a second system. The sequencing pressure is set via the adjustment type (4).

Version "C"

The compression spring (3) holds the control spool (2) in the initial position - the valve is blocked. Via the pilot line (5), the pressure in channel A② is applied to the spool face of the control spool (2) vis-à-vis the compression spring (3).

If the pressure in channel A② reaches the set value of the compression spring (3), the control spool (2) is pushed to the left and the connection A② to A① is opened. The system connected at A① is sequenced without a drop of the pressure in channel A②.

The leakage oil drain from the spring chamber (7) is always realized externally, via channel T (Y).

A pressure gauge connection (8) allows for the control of the sequencing pressure at the valve.

Version "A"

Here, the pressure is sequenced in channel A. Control signal and pilot fluid are provided internally, from channel A①.

Version "P"

With this version, the pressure is sequenced in channel P. Control signal and pilot fluid are provided internally, from channel P②.

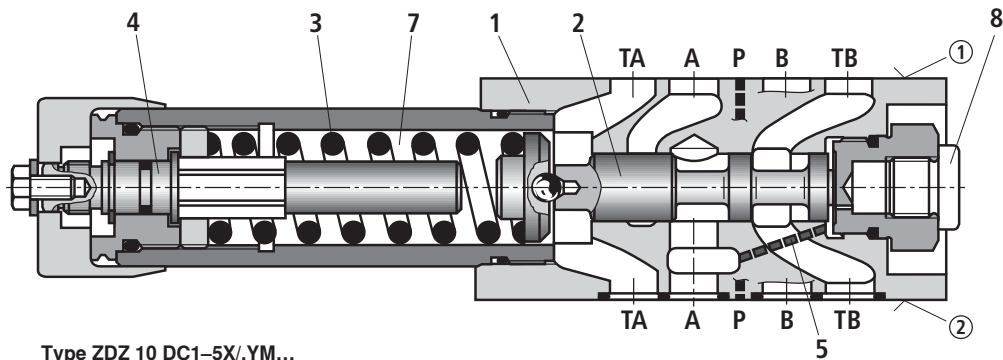

Type ZDZ 10 DC1-5X/YM...

① = component side

② = plate side

Technical data (For applications outside these parameters, please consult us!)

general

Weight	kg	Approx. 2.8
Installation position		Any
Ambient temperature range	°C	-30 to +80 (NBR seals) -20 to +80 (FKM seals)

hydraulic

Maximum operating pressure	- Port P, A, B	bar	210
	- Port T (Y)	bar	160
Maximum sequencing pressure (adjustable)		bar	25; 75; 150; 210
Maximum flow		l/min	80
Hydraulic fluid			Mineral oil (HL, HLP) according to DIN 51524 ¹⁾ ; Fast biodegradable hydraulic fluids according to VDMA 24568 (see also RE 90221); HETG (rape seed oil) ¹⁾ ; HEPG (polyglycols) ²⁾ ; HEES (synthetic esters) ²⁾ ; other hydraulic fluids upon request
Hydraulic fluid temperature range		°C	-30 to +80 (NBR seals) -20 to +80 (FKM seals)
Viscosity range		mm ² /s	10 to 800
Maximum permitted degree of contamination of the hydraulic fluid - cleanliness class according to ISO 4406 (c)			Class 20/18/15 ³⁾

¹⁾ Suitable for NBR and FKM seals

²⁾ Only suitable for FKM seals

³⁾ The cleanliness classes specified for the components must be adhered to in hydraulic systems. Effective filtration prevents faults and at the same time increases the service life of the components.

For selecting the filters, see data sheets RE 50070, RE 50076, RE 50081, RE 50086, RE 50087 and RE 50088.

Characteristic curves (measured with HLP46, $\vartheta_{oil} = 40 \pm 5 \text{ }^\circ\text{C}$)

Version "C"
 p - q_v characteristic curves

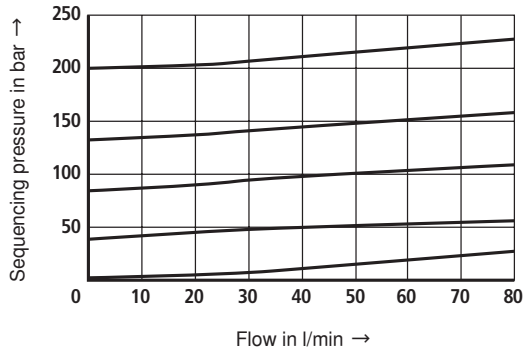

Characteristic curves for version "A" and "P" on request.

The characteristic curves apply to initial pressure = Zero in the entire flow range!

Unit dimensions (dimensions in mm)

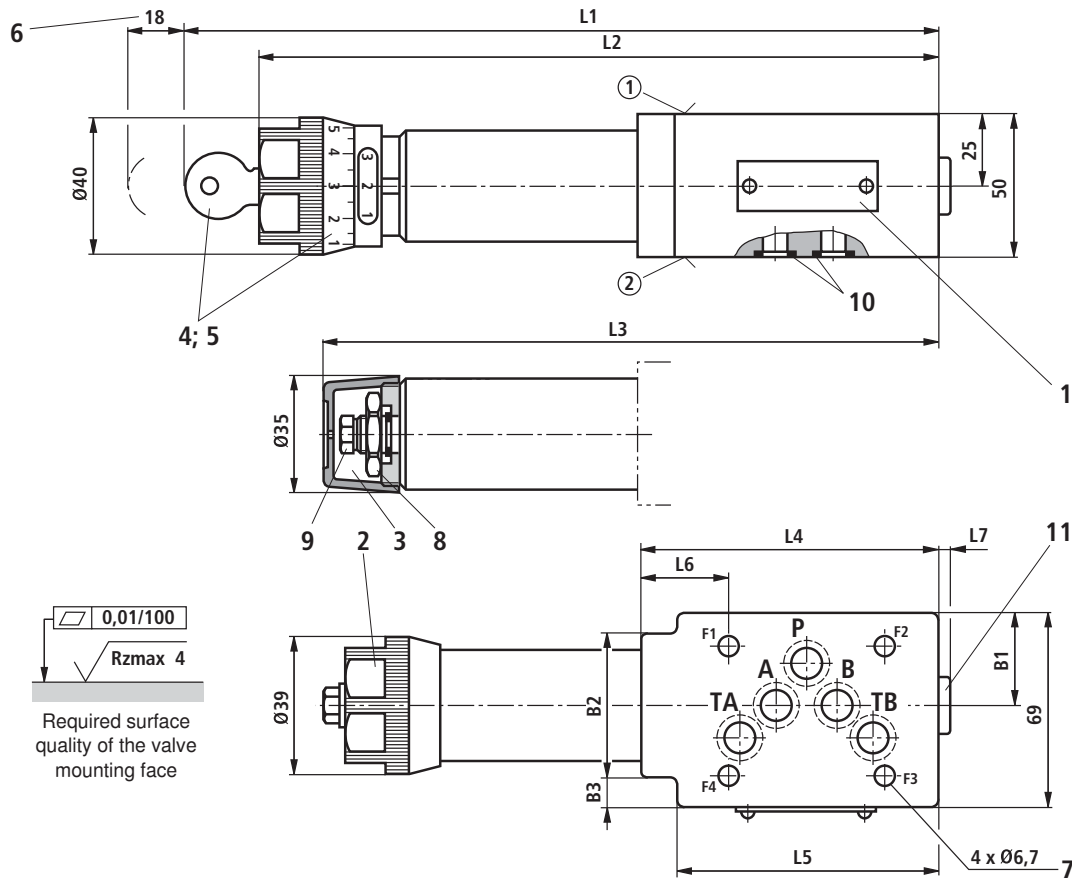

Version	L1	L2	L3	L4	L5	L6	L7	B2	B1	B3
"A"; "C"	255	231	210	104	93	31,5	4	51	32,9	12
"P"	242	218	198	91	-	18,5	16	-	34	-

- ① Component side – Porting pattern according to ISO 4401-05-04-0-05
- ② Plate side – Porting pattern according to ISO 4401-05-04-0-05

- 1 Nameplate
- 2 Adjustment type "1"
- 3 Adjustment type "2"
- 4 Adjustment type "3"
- 5 Adjustment type "7"
- 6 Dimensions required to remove the key
- 7 Valve mounting bores
- 8 Lock nut SW24
- 9 Hexagon SW10

- 10 Identical seal rings for ports A②, B②, P②, TA② and TB②; deviating from ISO 4401, port T is in this data sheet called TA, port T1 is called TB.
- 11 Pressure gauge connection G1/4, 12 deep; internal hexagon SW6

Valve mounting screws (separate order)

4 hexagon socket head cap screws
ISO 4762 - M6 - 10.9-fIZn-240h-L

Note!

Length and tightening torque of the valve mounting screws must be calculated according to the components mounted under and over the sandwich plate valve.

Notes

© This document, as well as the data, specifications and other information set forth in it, are the exclusive property of Bosch Rexroth AG. It may not be reproduced or given to third parties without its consent. The data specified above only serve to describe the product. No statements concerning a certain condition or suitability for a certain application can be derived from our information. The information given does not release the user from the obligation of own judgment and verification. It must be remembered that our products are subject to a natural process of wear and aging.