

Electric Drives  
and Controls

Hydraulics

Linear Motion and  
Assembly Technologies

Pneumatics

Service

**Rexroth**  
Bosch Group

## 3-way servo solenoid valves, cartridge type, pilot operated, with inductive position transducer

RE 29217/12.05

1/20

### Type 3WRCB 25...50

Nominal size (NG) 25, 32, 50  
Unit series 1X  
Maximum working pressure P, A, T, X, Z 315 bar  
Nominal flow rate  $Q_{nom}$  65...750 l/min



### Overview of Contents

Contents	Page
Features	1
Ordering data	2
Preferred types	2
Symbols and control oil supply	3
Function, sectional diagram	4
Overview	5 and 6
Technical data	7 and 8
Connection	8
On-board trigger electronics	9 to 11
External trigger electronics	12
Characteristic curves	13 and 14
Unit dimensions	15 to 17
Installation dimensions	18 to 20

#### Different versions on request

- For standard applications
- Special symbols for plastics machines
- Valve electronics (OBE) with 11P+PE interface possible

### Features

- Pilot operated servo solenoid valves NG25 to NG50
- Design: cartridge type, 3/2-way symbol  
Metering edges P–A / A–T
- Control spool with anti-rotation element and metering edges  
in servo quality
- Pressure-tight up to 315 bar
- Pilot line A–X generally required
- Dynamic return (B–Z) possible with the NG25 and NG50
- With inductive position transducer, position-controlled by the  
external pilot valve and the valve electronics
- Pilot valve mounted externally on valve block
- Hysteresis <0.1 %, scarcely measurable
- Flow characteristic
  - M = progressive with fine metering edge
- Plug-in connector for inductive position transducer (4P)  
included in scope of delivery
- Employed in electrohydraulic closed-loop controllers  
in production and testing systems
- Choice of pilot control:
  - 4WRPEH6... with on-board electronics, see RE 29035
  - 4WRPH6... with external electronics, see RE 29028 and  
RE 30045

## Ordering data

3WRCB	H	V		M	1X	Z	M
3/2-way cartridge servo solenoid valve							M =
Hydraulically actuated							Z =
NG25	= 25						1X =
NG32	= 32						M =
NG50	= 50						
Piston with zero overlap		= V					
Ratio of positioning surface area on piston 1:1			= no code				
1:1.5			= F				
<b>Nominal flow rate l/min (with 5 bar pressure drop at valve)</b>							
<b>NG25</b>							
65 l/min			= 65				
190 l/min			= 190				
<b>NG32</b>							
380 l/min			= 380				
<b>NG50</b>							
300 l/min			= 300				
750 l/min			= 750				

NBR seals,  
suitable for mineral oils  
(HL, HLP) to DIN 51524

Additional control oil port\*

Unit series 10 to 19  
(10 to 19: installation and connection  
dimensions unchanged)

Non-linear characteristic  
Progressive with linear fine metering range

\* Not possible for NG32

## Preferred types

Type	Material Number
<b>NG25</b>	
3WRCBH25VF65M-1X/ZM	0 811 402 513
3WRCBH25VF190M-1X/ZM	0 811 402 514
<b>NG32</b>	
3WRCBH32V380M-1X/M	0 811 402 611
<b>NG50</b>	
3WRCBH50VF750M-1X/ZM	0 811 402 639
3WRCBH50VF300M-1X/ZM	0 811 402 640

### Note

You can find an overview of and further information  
on the pilot valves and accessories on pages 5 and 6.

## Symbols and control oil supply

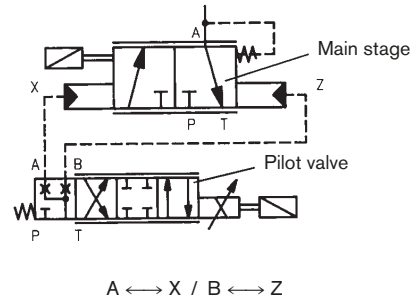
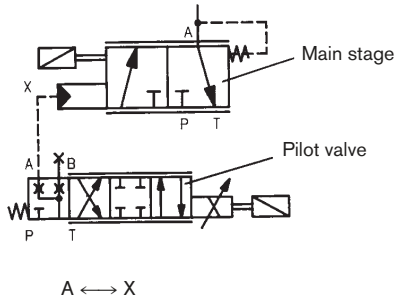

NG32, with A-X

NG25, 50 with A-X and B-Z

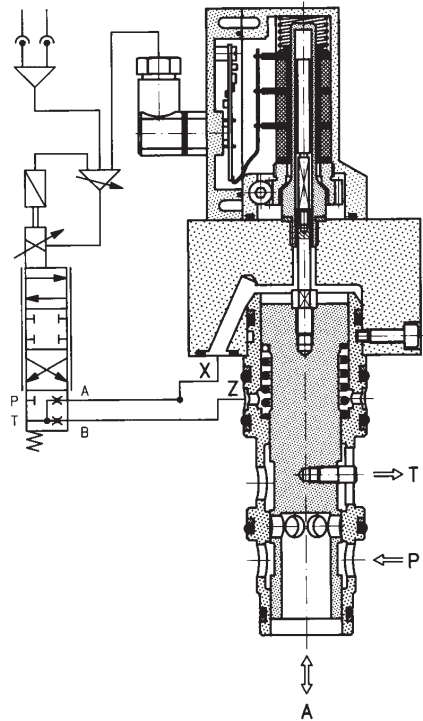
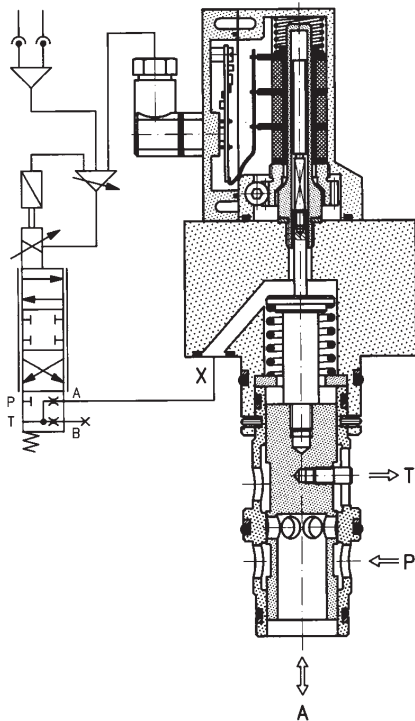

## Function, sectional diagram

### General

3/2-way cartridge servo solenoid valves are pilot operated main stages with two metering edges, P-A / A-T. At the transition, fine metering edges ensure minimum oil leakage with high, linear pressure gain. The spool position is deflected by the control oil of the pilot valve. If X is relieved of pressure, the load pressure in A and the internal spring cause the spool to return (symbol A-T). The position of the spool is detected by an inductive position transducer, and its signal together with the valve electronics allows closed-loop position control by an NG6 pilot servo solenoid valve. Hysteresis is <math><0.1\%</math> and thus scarcely measurable. The design of these valves is extremely compact, and is frequently employed in the plastics branch in injection molding cylinders. Pressure relief takes place by way of the metering edge A-T. The NG25 and NG50 valves also offer a port Z, which enables a faster return when there is little load in A. For this purpose, the pilot valve must be connected to A-X and B-Z.

### Basic principle

Pilot operated 3/2-way cartridge servo solenoid valves have metering edges in servo quality, see characteristic curves. The spool position is measured by an inductive position transducer and processed by the external position control. The following components are required for the external position control:

- Pilot valve 4WRP(E)H 6
- Valve electronics, internal (OBE) or external
- Valve block (provided by customer).

The switching of control oil in the valve block and the electrical connection together form the basis of the pilot operated valve function for closed-loop control tasks in the system. This is mostly a process for speed and pressure control. The system's process controllers form the valve signal for the control loop.

### Pilot valve

with on-board electronics (OBE)

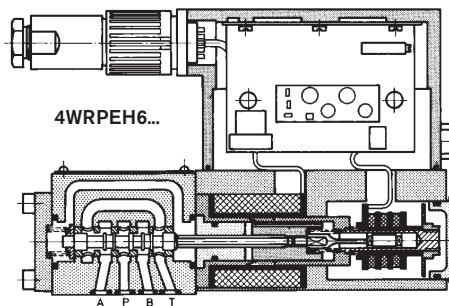

or with external electronics

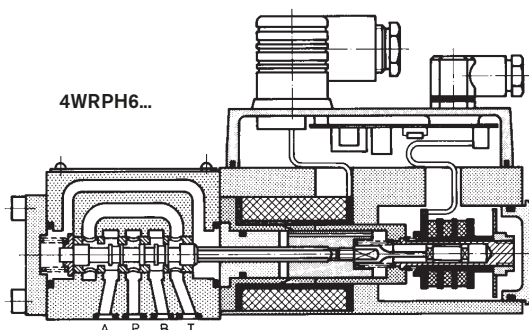

### Main stage

3/2-way cartridge servo solenoid valve  
3WRCB 25...50

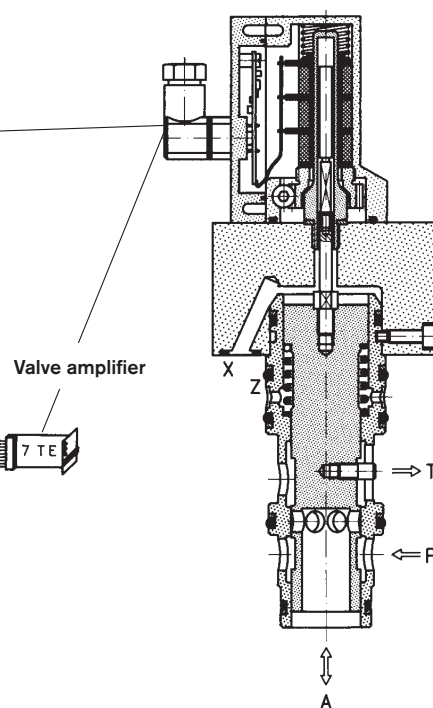



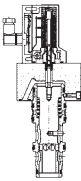
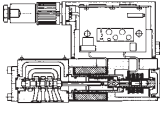

## Overview

### 3WRCB25...50 with on-board electronics (OBE)

Main stage			Pilot valve			
3WRCB25...50	NG	Material Number	4WRPEH6...	$Q_N$ l/min	Material Number Signal $\pm 10$ V	Material Number Signal 4...20 mA
	25	0 811 402 513		12	0 811 404 601	0 811 404 632
		0 811 402 514				
	50	0 811 402 611		24	0 811 404 602	0 811 404 633
		0 811 402 639		40	0 811 404 603	0 811 404 634
		0 811 402 640				

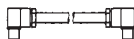
## Accessories

Type		Material Number
	PG7	Included in scope of delivery
(4x) 	ISO 4762	
		1 834 463 005
(4x) 	ISO 4762	2 910 151 166
	Plug-in connector 6P+PE for 4WRPEH6..., see also RE 08008	KS - PG11
		KS - PG11
		MS - PG11
		MS - PG16
		KS - PG11 - 90°
		1 834 482 022
		1 834 482 026
		1 834 482 023
		1 834 482 024
		1 834 484 252

## Cable for main stage and pilot valve (4WRPEH6...)

This cable is used to connect the main stage to the pilot valve.

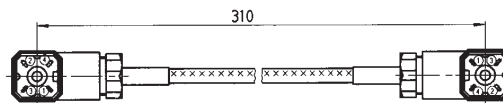

	Cable for connecting main stage to pilot valve	<b>Material Number</b> 1 834 463 005
---	--	---

## Testing and service equipment





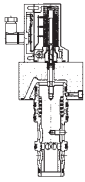
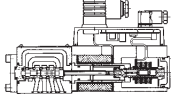

Test box type VT-PE-TB3, see RE 30065  
Measuring adapter 6P+PE type VT-PA-2, see RE 30068

## Overview

### 3WRCB25...50 with external electronics

Main stage			Pilot valve		
3WRCB25...50	NG	Material Number	4WRPH6...	$Q_N$ l/min	Material Number Signal $\pm 10$ V
	25	0 811 402 513		12	0 811 404 034
		0 811 402 514			
	50	0 811 402 611		24	0 811 404 035
		0 811 402 639			
	0 811 402 640	40	0 811 404 036		

## Accessories

Type	Material Number
 PG7 Plug-in connector 4P for 3WRCB25...50	Included in scope of delivery
(4x)  ISO 4762 Cheese-head bolts for 3WRCB25...50	
 M16x1,5  PG7 Plug-in connector 4P and 2P+PE for 4WRPH6...	2 910 151 166
(4x)  ISO 4762 Cheese-head bolts M5x30 for 4WRPH6...	
 Europe card VT-VRR1-527-20/V0/2STV, see RE 30045	0 811 405 063

## Testing and service equipment

Test box type VT-PE-TB2, see RE 30064  
Test adapter type VT-PA-3, see RE 30070

## Technical data

### General

Construction	3/2-way cartridge servo solenoid valve, pilot operated main stage
Actuation	Servo solenoid valve NG6, on the block as a separate pilot valve
Type of mounting	Cartridge type, see installation dimensions
Installation position	Horizontal, or position transducer facing downwards
Ambient temperature range	°C -20...+50
Vibration resistance, test condition	Max. 25 g, shaken in 3 dimensions (24 h)

### Hydraulic (measured with HLP 46, $\vartheta_{oil} = 40^\circ\text{C} \pm 5^\circ\text{C}$ )

Pressure fluid	Hydraulic oil to DIN 51524...535, other fluids after prior consultation				
Viscosity range	recommended	mm <sup>2</sup> /s	20...100		
	max. permitted	mm <sup>2</sup> /s	10...800		
Pressure fluid temperature range	°C	-20...+80			
Maximum permitted degree of contamination of pressure fluid Purity class to ISO 4406 (c)	Class 18/16/13 <sup>1)</sup>				
Direction of flow	See symbols				
Nominal flow rate at $\Delta p = 5$ bar per edge <sup>2)</sup>	l/min	NG25		NG32	NG50
		65	190	380	300 750
Max. working pressure	bar	Port P, A, T, X, Z: 315			
$Q_{max}$	l/min	200	570	1000	900 2250
$Q_N$ pilot valve	l/min	12		24	40
Leakage Pilot valve at 100 bar	$\frac{\text{cm}^3}{\text{min}}$	<300		<500	<900
Leakage Main stage at 100 bar	$\frac{\text{cm}^3}{\text{min}}$	<350	<350	<500	<500 <600
Control oil flow $p = 100$ bar and at max. dynamics	l/min	8		16	28
Control oil pressure "pilot stage"	bar	min. = $p_A + 4$			

All above characteristics valid only in connection with valve 4WRPEH6..., see page 5.

<sup>1)</sup> The purity classes stated for the components must be complied with in hydraulic systems. Effective filtration prevents problems and also extends the service life of components. For a selection of filters, see catalog sheets RE 50070, RE 50076 and RE 50081.

<sup>2)</sup> Flow at a different  $\Delta p$

$$Q_x = Q_{nom} \cdot \sqrt{\frac{\Delta p_x}{5}}$$

### Important

Information on  $Q_{nom}/Q_{max}$  only applies if installation dimensions are complied with.

## Technical data

### Static/Dynamic

Hysteresis	%	< 0.1, scarcely measurable		
Manufacturing tolerance	%	≤ 10		
Response time for signal change 0...100% ( $p_X = 100 \text{ bar}/p_A = 50 \text{ bar}$ ) A-X	ms	<b>NG25</b>	<b>NG32</b>	<b>NG50</b>
		33	28	60
Response time for signal change 0...100% ( $p_X = 100 \text{ bar}/p_A = 50 \text{ bar}$ ) A-X/B-Z	ms	27	-	50
Switch-off behavior	After electrical switch-off: pilot valve in "fail-safe", main stage moves to "A-T" symbol position			
Thermal drift	Zero drift < 1% at $\Delta T = 40^\circ\text{C}$			
Zero calibration	Adjustable by $\pm 5\%$ on valve amplifier, pilot valve with OBE factory-set			

### Electrical

Position transducer DC/DC technology	Supply: +15 V/35 mA -15 V/25 mA	Signal: 0...±10 V ( $R_L \geq 10 \text{ k}\Omega$ )
---	------------------------------------	---

All above characteristics valid only in connection with valve 4WRPEH6..., see page 5.

## Connection

For electrical data, see page 7 and  
Operating Instructions **1 819 929 083**

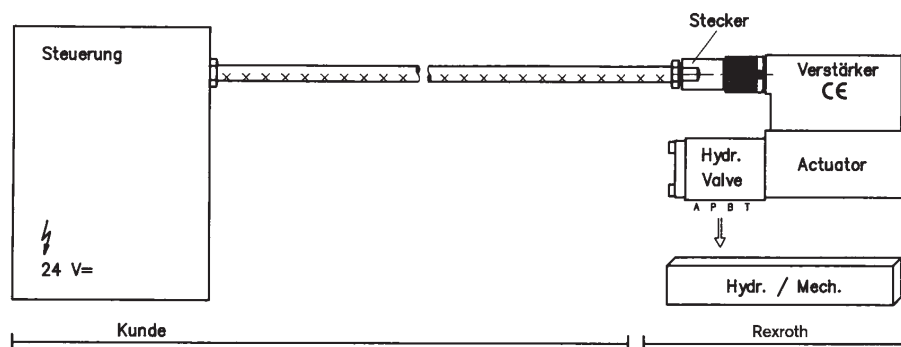

### Technical notes for the cable

- Design:**
- Multi-wire cable
  - Extra-finely stranded wire to VDE 0295, Class 6
  - Safety earth conductor, green/yellow
  - Cu braided shield
- Type:**
- e.g. Ölflex-FD 855 CP (from Lappkabel company)
- No. of wires:**
- Determined by type of valve, plug type and signal assignment
- Cable Ø:**
- 0.75 mm<sup>2</sup> up to 20 m long
  - 1.0 mm<sup>2</sup> up to 40 m long
- Outside Ø:**
- 9.4...11.8 mm - Pg11
  - 12.7...13.5 mm - Pg16

### Important

Power supply 24 V DC nom., if voltage drops below 18 V DC, rapid shutdown resembling "Enable OFF" takes place internally.

In addition, with the "mA signal" version:

$I_{D-E} \cong 3 \text{ mA}$  - valve is active  
 $I_{D-E} \cong 2 \text{ mA}$  - valve is deactivated.

Electrical signals (e.g. actual values) emitted via the trigger electronics must not be used to shut down safety-relevant machine functions!

(Also see European Standard, "Technical Safety Requirements for Fluid-Powered Systems and Components - Hydraulics", EN 982.)

## On-board trigger electronics

### Circuit diagram/pin assignment

Version A1:  $U_{D-E} 0...±10 V$

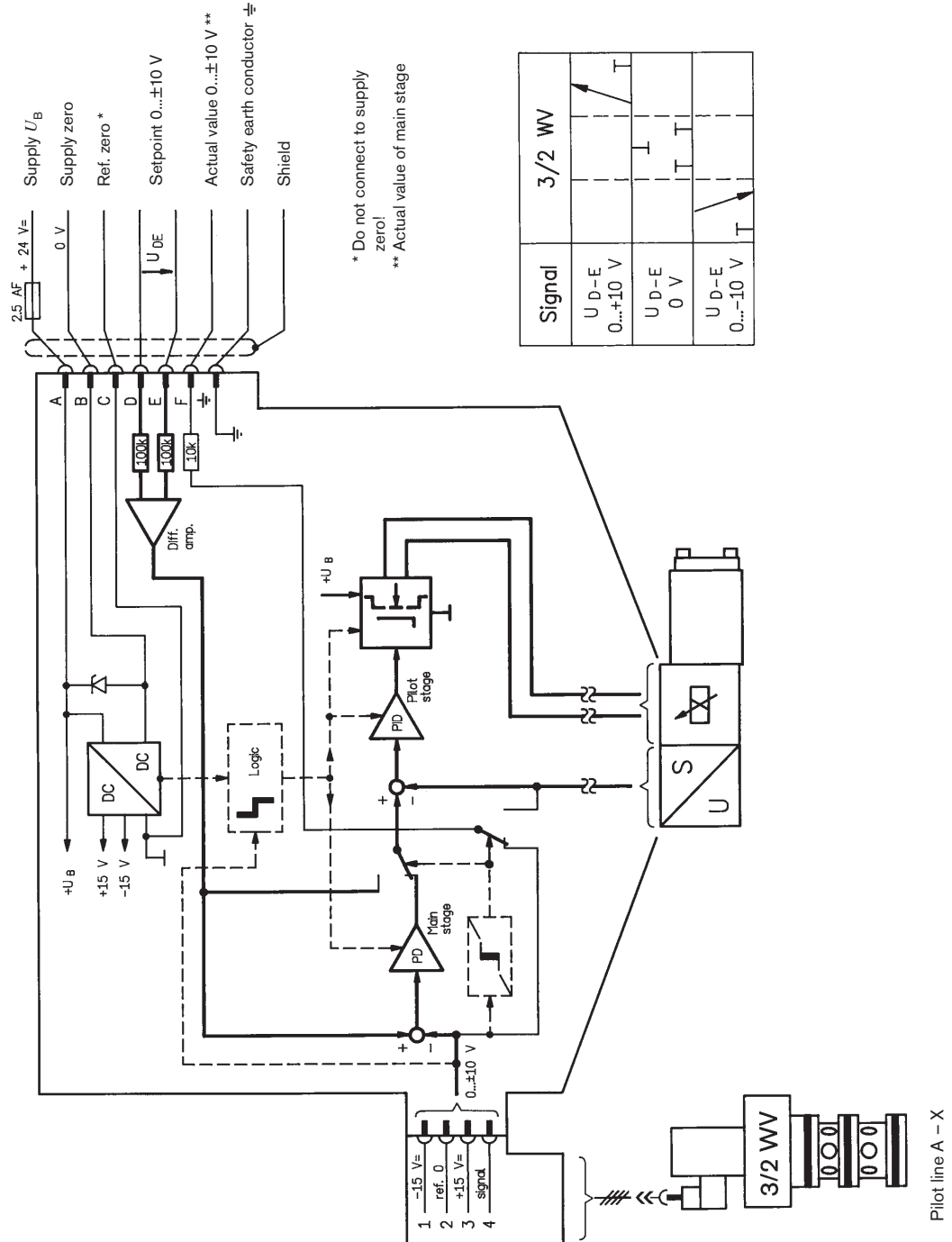

## On-board trigger electronics

### Circuit diagram/pin assignment

Version F1:  $I_{D-E}$  4...20 mA

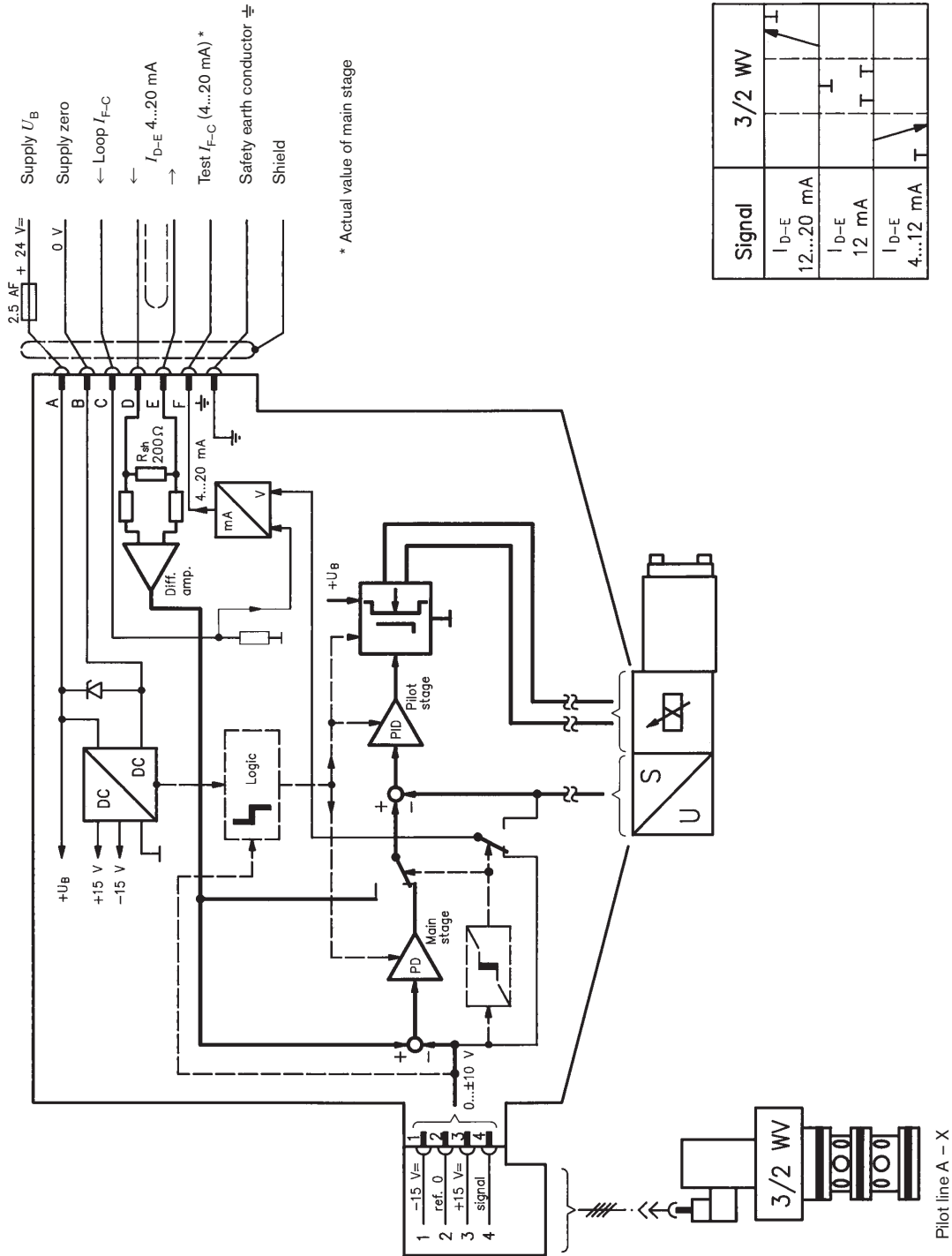

## On-board trigger electronics

### Pin assignment 6P+PE

Version A1:  $U_{D-E}$  0...±10 V  
( $R_1 = 100 \text{ k}\Omega$ )

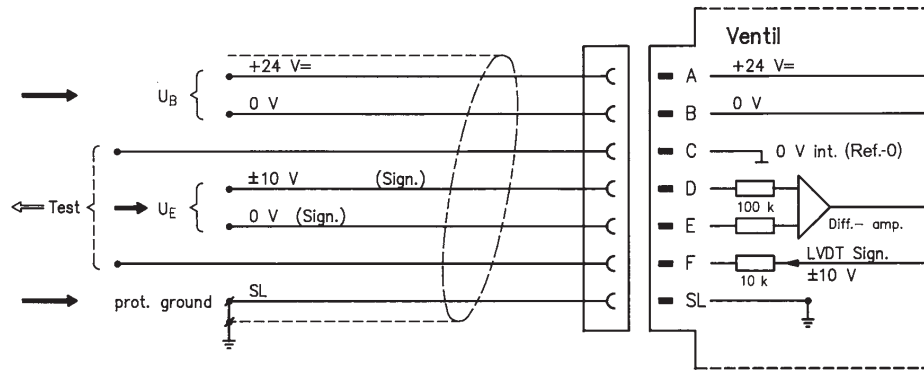

### Pin assignment 6P+PE

Version F1:  $I_{D-E}$  4...20 mA  
( $R_{sh} = 200 \Omega$ )

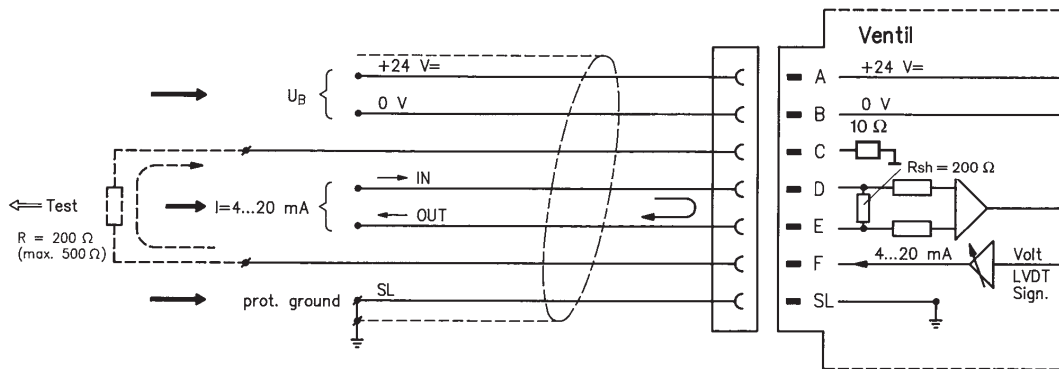

## Valve with external trigger electronics (Europe card, RE 30045)

### Circuit diagram/pin assignment

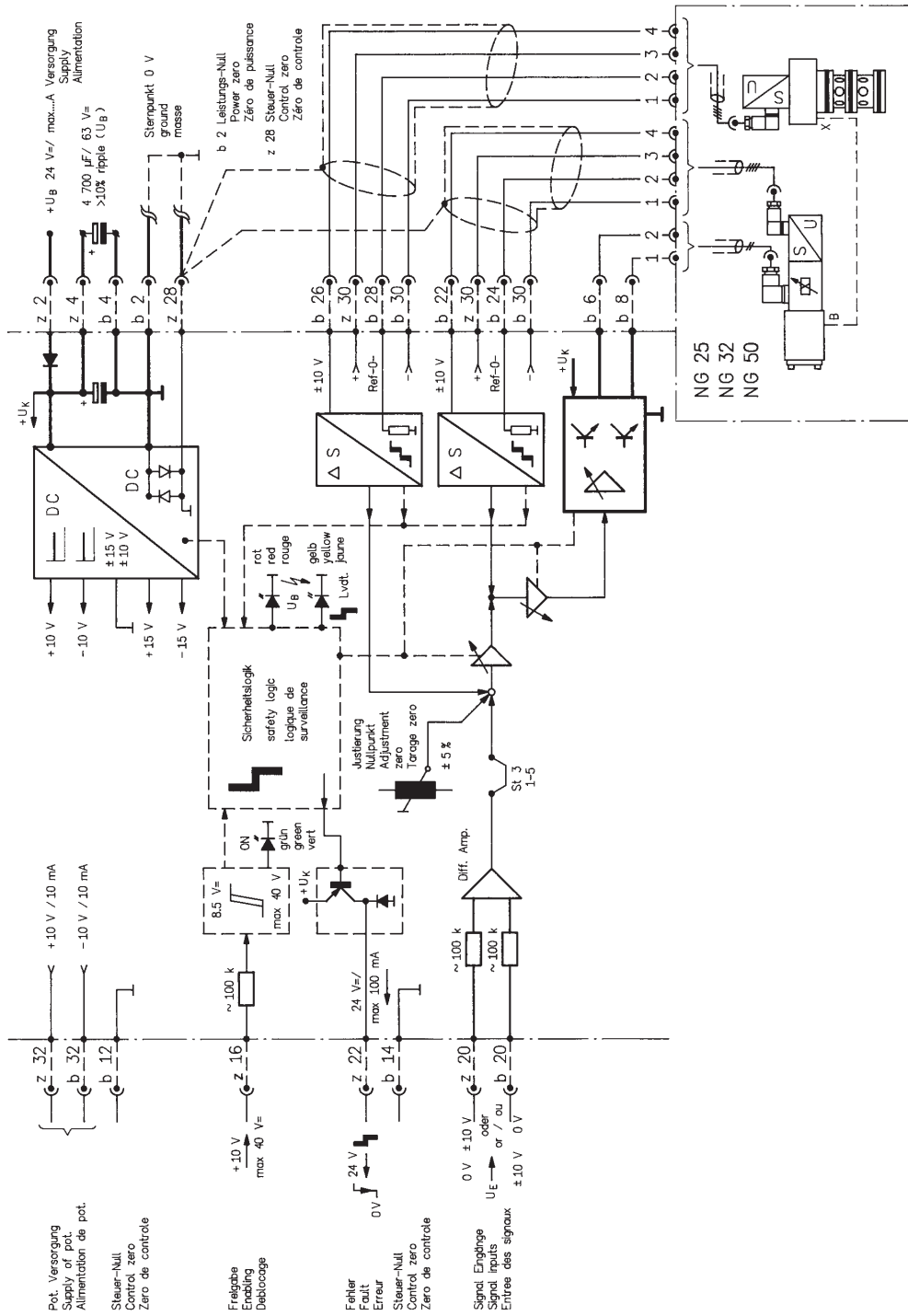

## Characteristic curves (measured with HLP 46, $\vartheta_{oil} = 40^\circ\text{C} \pm 5^\circ\text{C}$ )

### Flow rate/signal function

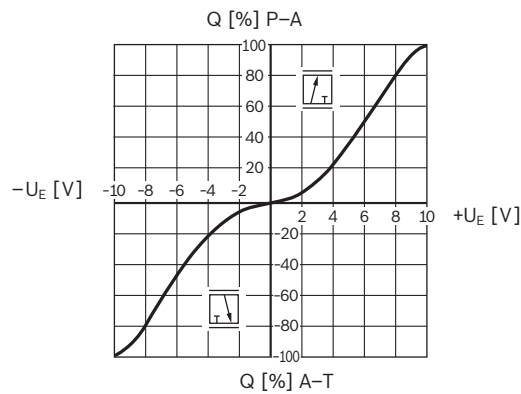

### Pressure gain

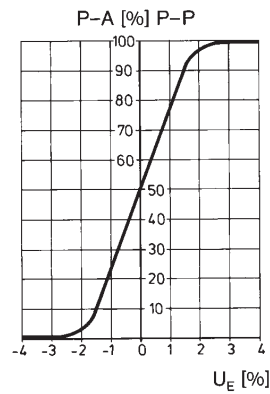
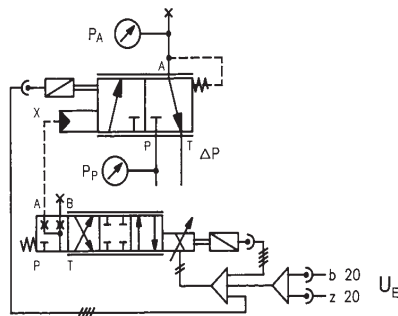

## Characteristic curves (measured with HLP 46, $\vartheta_{oil} = 40^\circ\text{C} \pm 5^\circ\text{C}$ )

### Bode diagram

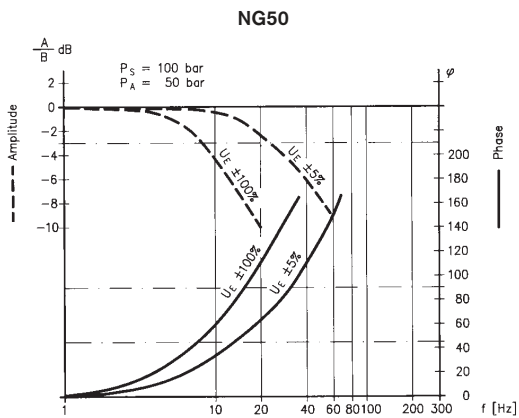
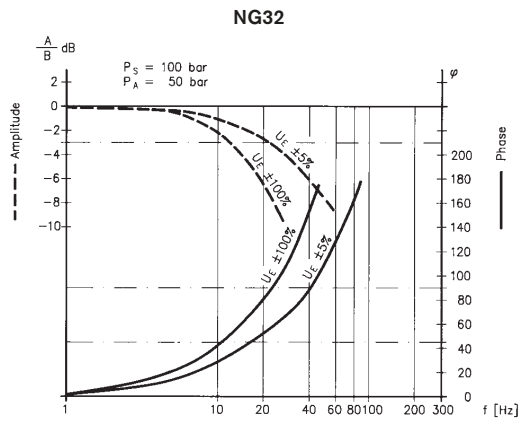
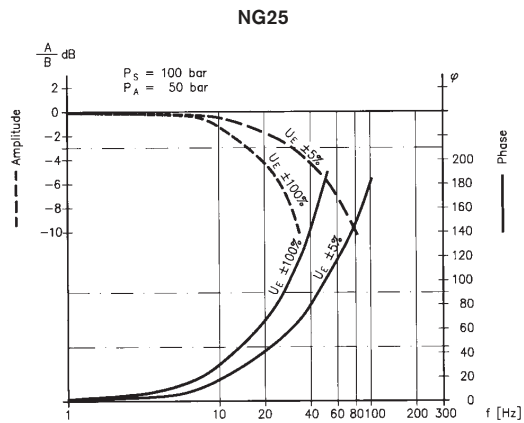
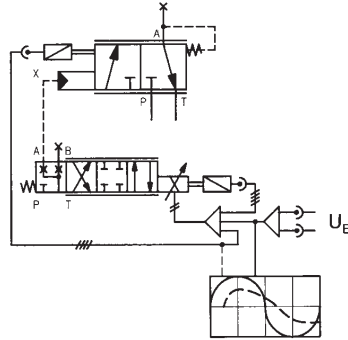

## Unit dimensions NG25 (nominal dimensions in mm)

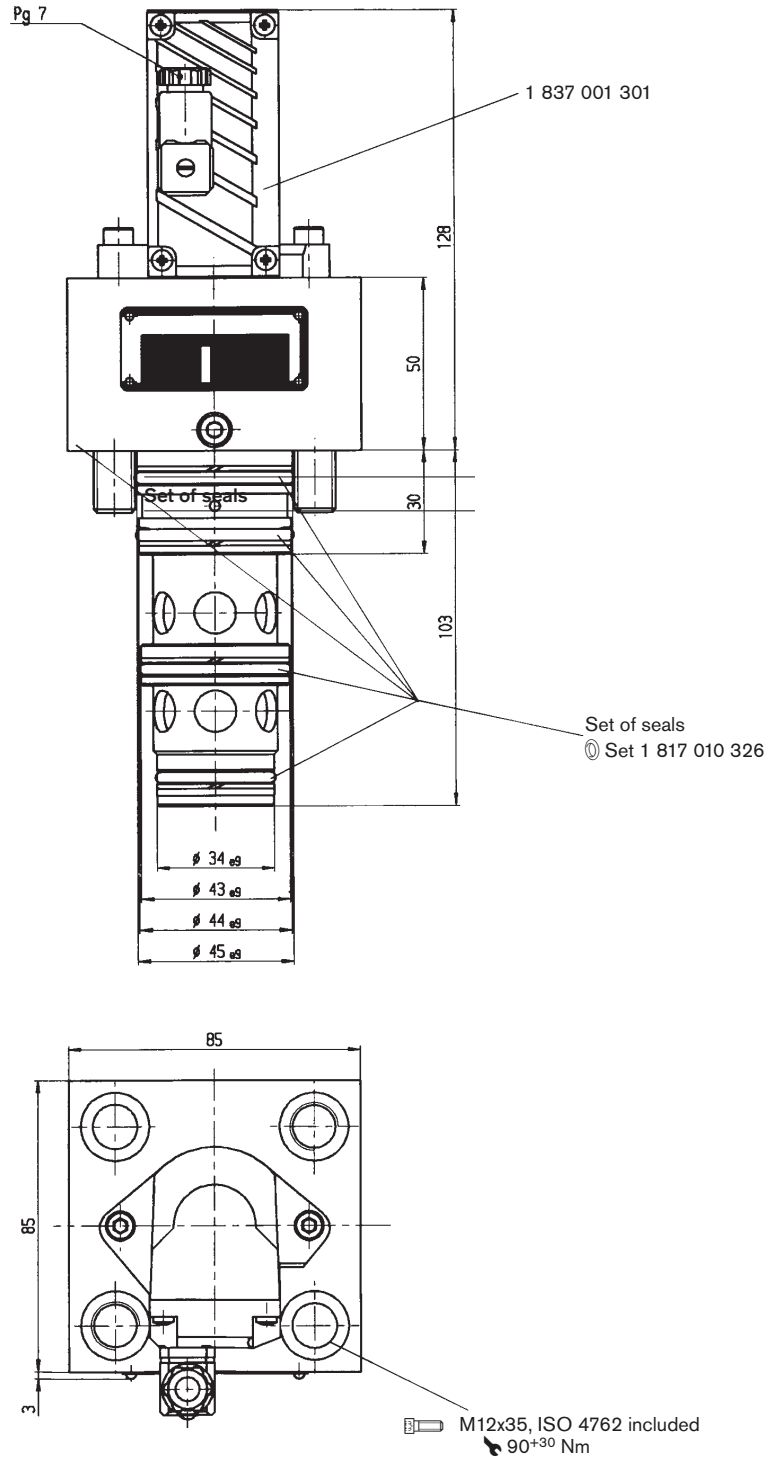

See installation dimensions on page 18

## Unit dimensions NG32 (nominal dimensions in mm)

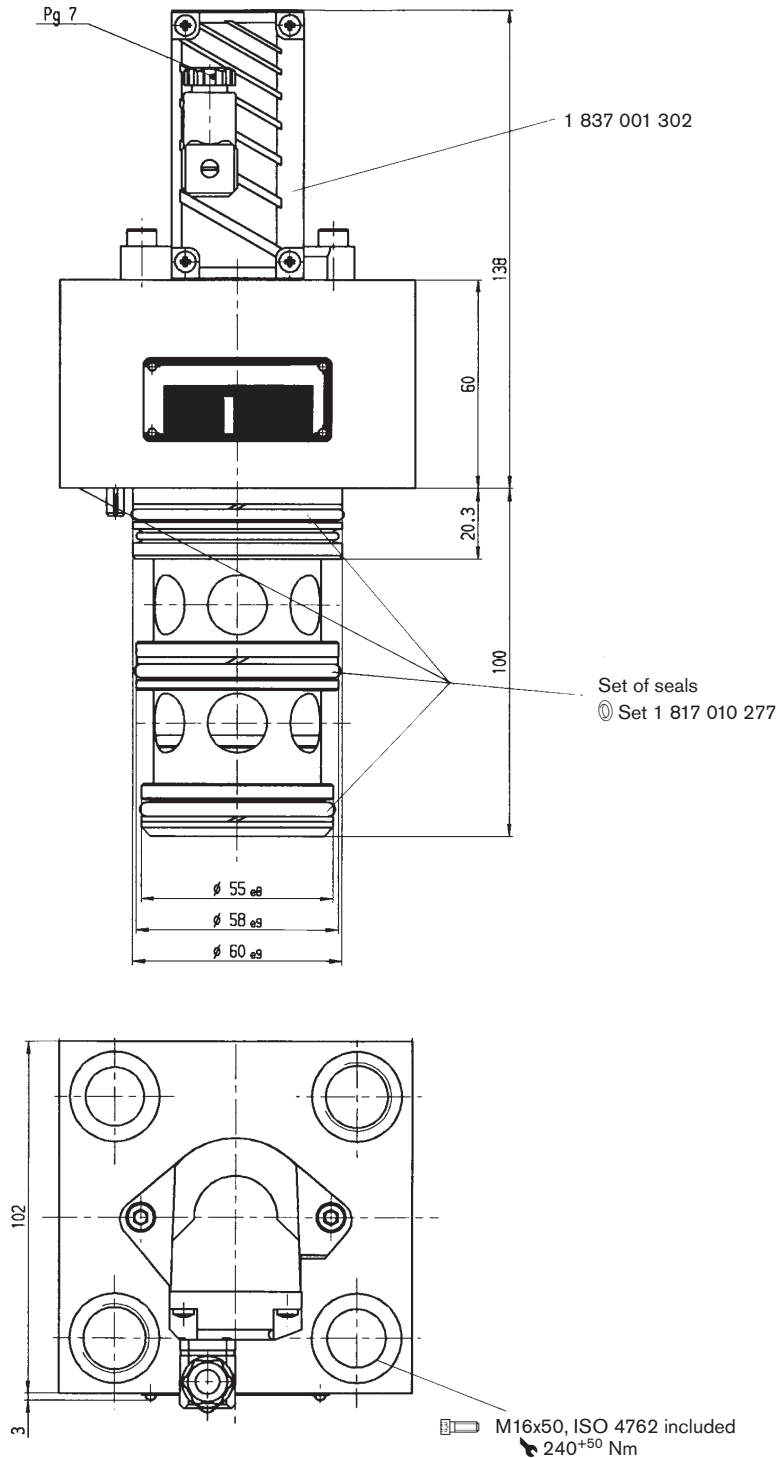

See installation dimensions on page 19

## Unit dimensions NG50 (nominal dimensions in mm)

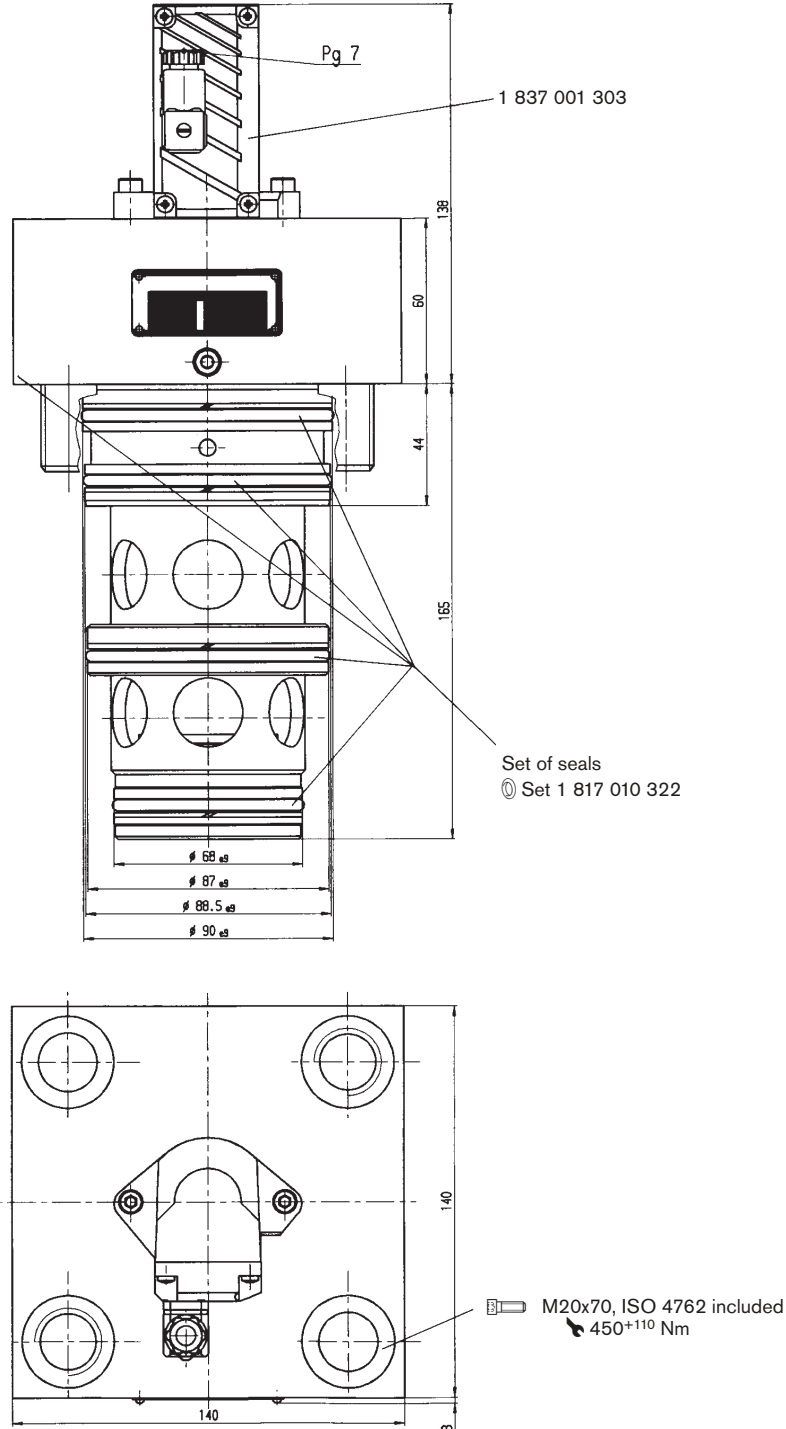

See installation dimensions on page 20





