



ROEMHELD
HILMA ■ STARK

Issue 10-15 E

B 1.553

Block Cylinder

with bronze housing for adjustable magnetic sensors,
double acting, max. operating pressure 500 bar

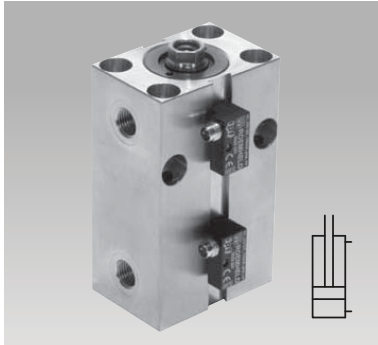

Application

Compact, double-acting short-stroke cylinder with very high press and pulling force and adjustable control of the piston position by magnetic sensors.

Description

The cylinder housing of this variante of the proved ROEMHELD block cylinders consists of a non-magnetizable bronze alloy. A permanent magnet is fixed at the piston, the magnetic field of the piston can be monitored by exterior magnetic sensors. The magnetic sensors are guided in dovetail slots and allow a continuous control of the piston position.

Advantages

- 5 sizes with 3 stroke lengths
- Compact block design
- Same dimensions as block cylinder with aluminium housing, as per data sheet B 1.554
- Same dimensions as block cylinder with steel housing, except for total length
- Many fixing possibilities
- Fixing screws countersunk
- Oil supply optionally with fittings or by drilled channels
- Magnetic sensors can be used up to 100 °C
- Fixing of the sensors at 2 sides possible
- Easy adjustment of switching point positions
- Corrosion-resitant version available
- FKM seals available
- Maintenance free

Variants available:
◆ Shorter stroke
◆ Keyway
◆ Internal thread instead of mounting holes in the body
Corrosion-resistant version available

Fixing possibilities

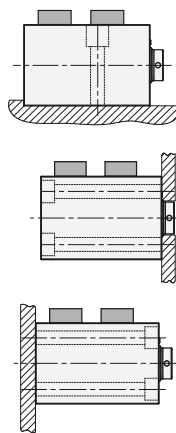

Connecting possibilities

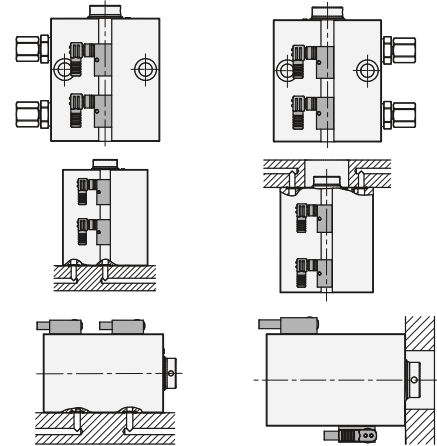

Important notes

1. Fittings

Use only fittings with elastic sealing instead of knife-edge sealing (see data sheet F 9.300). Fittings with tapered thread must not be used.

2. Flow control of the oil flow

Throttling has to be made in the oil supply line to the block cylinder. This avoids pressure intensification and thereby pressures exceeding 500 bar. The hydraulic circuit diagram shows flow control valves which allow oil return from the block cylinder without any impediments.

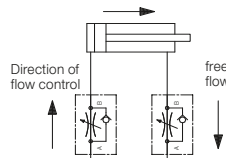

3. Influence of the magnetic field

Due to steel in the immediate vicinity of the block cylinder the magnetic field of the piston will be deflected. Thereby the switching points of the magnetic sensors are displaced and a modified adjustment will be required.

If absolutely no defined switching point can be adjusted, one can try to use fixing screws made of special stainless steel. In case of ferritic swarf, the conditions differ from stroke to stroke and thereby an exact adjustment is impossible. In such applications a cover can solve the problem, however the distance to the magnetic sensors has to be at least 30 mm.

4. Cleanness of the hydraulic oil

Ferritic swarf in the hydraulic oil are attracted by the permanent magnet at the piston and accumulate in the cylinder area. Thereby guides and sealings can be damaged. Therefore all tubes, hoses and drilled channels have to be carefully cleaned before start up. We recommend high-pressure filters with filter quality of 10 µm (see data sheet F 9.500).

5. Admissible operating pressure

Magnetic sensor	154X-X5X Perbunan	154X-X6X FKM
without	-25 ... +100 °C	-20 ... +120 °C
with	-25 ... +100 °C	-20 ... +100 °C

6. Materials

The cylinder housing consists of a bronze alloy, the piston of case-hardening steel and the threaded bushing of free-cutting steel. Piston and threaded bushing of the corrosion-resistant version (154X-4XX) are of special stainless steel

Other data see data sheet A 0.100.

Application example

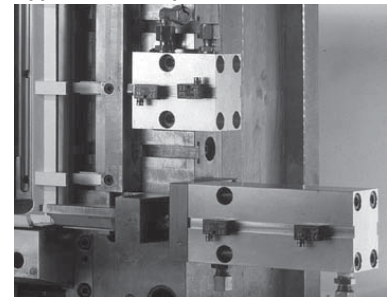

Connecting thread for fittings with elastic sealing
(see "Important notes")

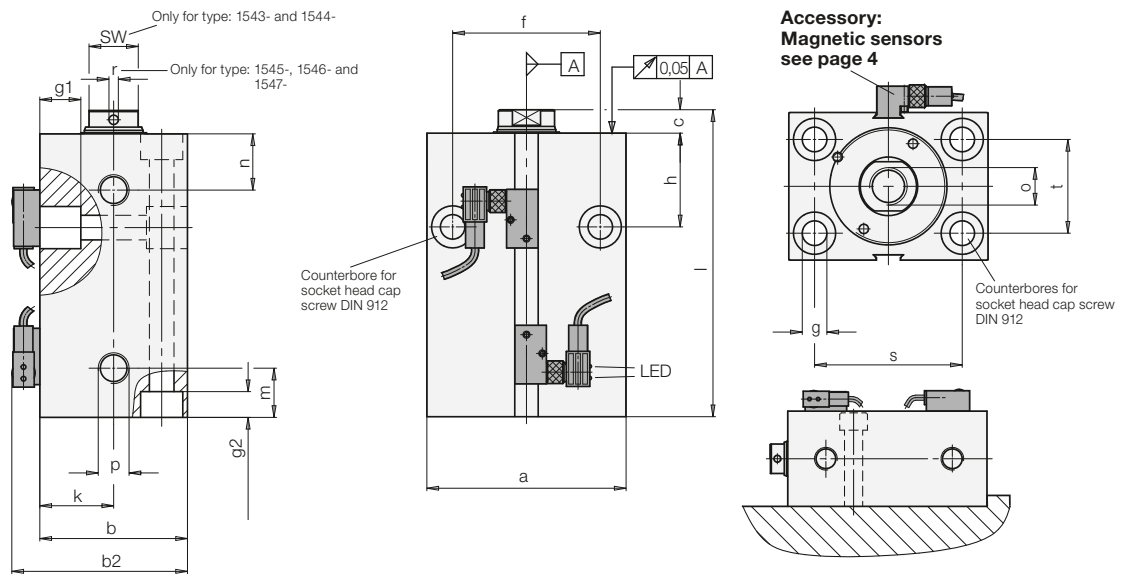

Cylinders must be backed up for operating pressures exceeding 160 bar.

Piston Ø D	[mm]	25	32	40	50	63
Rod Ø d	[mm]	16	20	25	32	40
Force to push at	100 bar [kN]	4.9	8.0	12.5	19.6	31.2
	500 bar [kN]	24.5	40.2	62.8	98.5	156
Force to pull at	100 bar [kN]	2.9	4.9	7.7	11.6	18.6
	500 bar [kN]	14.5	24.5	38.3	57.9	93
Oil volume// 10 mm stroke	Stroke to extend [cm³]	4.91	8.05	12.56	19.63	31.17
	Stroke to retract [cm³]	2.9	4.9	7.7	11.6	18.6
a	[mm]	65	75	85	100	125
b	[mm]	45	55	63	75	95
b2	[mm]	57	67	75	87	107
c	[mm]	7	10	10	10	14
f	[mm]	50	55	63	76	95
g	[mm]	8.5	10.5	10.5	13	17
g1 at both sides	[mm]	12	16	17	22	—*
g2 at both sides	[mm]	9	11	11	13	17
h	[mm]	33	38	40	44	50
k	[mm]	22.5	27.5	31.5	37.5	47.5
m	[mm]	18	20	21	21	26
n	[mm]	18	22	24	27	26
o x depth of thread	[mm]	M10 x 15	M12 x 15	M16 x 25	M20 x 30	M27 x 40
p		G 1/4	G 1/4	G 1/4	G 1/4	G 1/2
r	[mm]	—	—	4	4	4
s	[mm]	50	55	63	76	95
t	[mm]	30	35	40	45	65
SW	[mm]	13	17	—	—	—

Stroke ±1	[mm]	20	25	25	25	30
Total length l ±1	[mm]	85	100	106	117	135
Weight	[kg]	1.3	2.2	3.1	4.8	8.6
Part no. (without magnetic sensors)		1543-553	1544-553	1545-553	1546-553	1547-553

Stroke ±1	[mm]	50	50	50	50	63
Total length l ±1	[mm]	115	125	131	142	168
Weight	[kg]	1.9	2.8	3.9	5.9	11
Part no. (without magnetic sensors)		1543-556	1544-556	1545-556	1546-556	1547-556

Stroke ±1	[mm]	100	100	100	100	100
Total length l ±1	[mm]	165	175	181	192	205
Weight	[kg]	2.8	4	5.5	8.2	13.6
Part no. (without magnetic sensors)		1543-559	1544-559	1545-559	1546-559	1547-559

Part no.
154X-4XX
154X-X6X

Version
corrosion-resistant
FKM seals (see page 1 "Admissible operating pressure")

* Type 1547 without counterbores

Manifold mounting with O-ring sealing Identification letters K, L, S, B

Oil supply and O-ring sealing at:

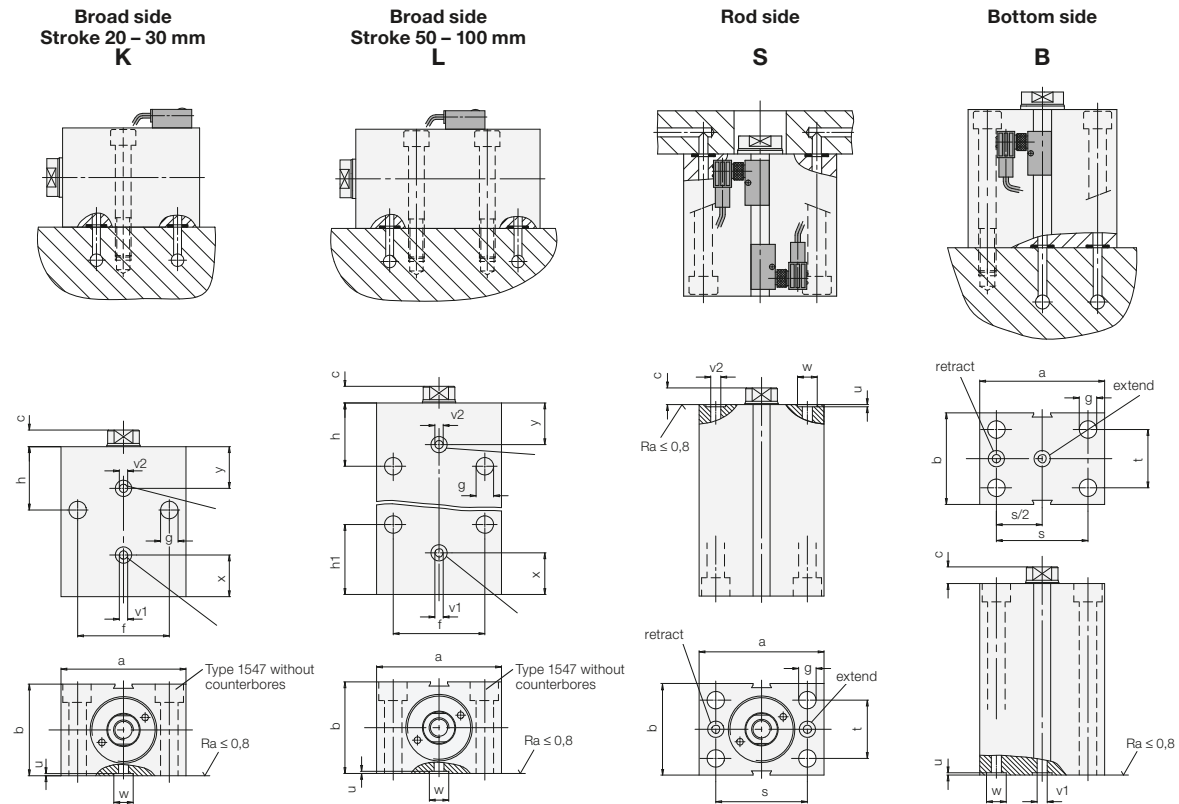

Block cylinder		1543-XXX	1544-XXX	1545-XXX	1546-XXX	1547-XXX
Piston Ø	[mm]	25	32	40	50	63
Rod Ø	[mm]	16	20	25	32	40
a	[mm]	65	75	85	100	125
b	[mm]	45	55	63	75	95
c	[mm]	7	10	10	10	14
f	[mm]	50	55	63	76	95
g	[mm]	8.5	10.5	10.5	13	17
h	[mm]	33	38	40	44	50
h1	[mm]	40	42	44	47	60
s	[mm]	50	55	63	76	95
t	[mm]	30	35	40	45	65
u ± 0.05	[mm]	1.1	1.1	1.1	1.1	1.3
v1	[mm]	4	5	6	6	8
v2	[mm]	4	4.5	4.5	6	6
w + 0.2	[mm]	9.8	10.8	10.8	10.8	15.8
x	[mm]	21.5	25	27	30	35
y	[mm]	21	25	27	29.5	32
Dimensions O-ring	[mm]	7 x 1.5	8 x 1.5	8 x 1.5	8 x 1.5	12.42 x 1.78
Part no. spare O-ring		3000-342	3000-343	3000-343	3000-343	3000-335
Part no. O-ring (FKM)		3001-077	3000-275	3000-275	3000-275	3001-152

O-rings are included in delivery.

Other dimensions see page 2.

Order:

Please add the identification letters **K, L, S, or B** to the Part no. of the required block cylinder

Example of ordering:

Double-acting block cylinder 1545-553 (25 stroke) with oil supply at the broad side

Part no. 1545-553 K

Accessory: Magnetic sensors

Compared with traditional reed switches the electronic magnetic sensors offer the following advantages:

- Indifference to shock and vibration
- Bounce-free output signal
- Only one switching point
- Wear resistant
- Protection against reverse battery
- Protected against short circuits

Electric connection is made as per traditional inductive proximity switches; up to four magnetic sensors can be connected in series.

Minimum distance of the switching points: 6 mm.

For further information about voltage supply for position controls see data sheet G 2.140.

Electronic magnetic sensor

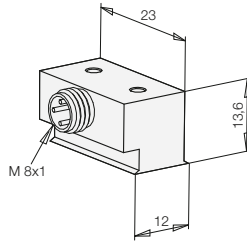

Temperature curve

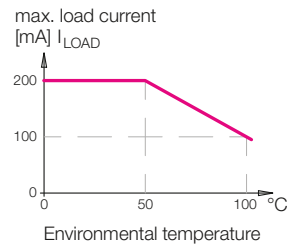

Connecting cable with right angle plug

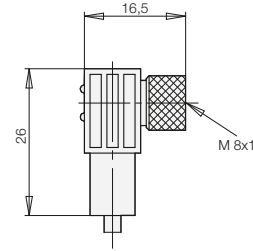

Connecting scheme

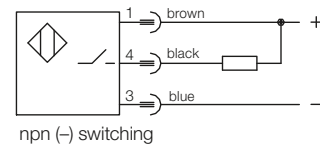
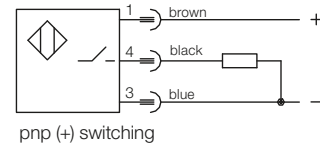

Technical data	Electronic magnetic sensor		Connecting cable with right angle plug	
Body material	aluminium black lacquered			
Voltage	10 – 30 V DC		10 – 30 V DC	
Residual ripple	max. 10%			
Current load I _{LOAD}	200 mA – up to 50 °C 150 mA – at 75 °C 100 mA – at 100 °C			
Current consumption	< 15 mA			
Voltage drop (max. load)	< 2 V			
Protected against short circuits	yes			
Protection against reverse battery	installed			
Switching frequency	1 kHz			
Switching hysteresis	3 mm			
Protection as per DIN 40050	IP 67		IP 67	
Environmental temperature	–25 °C up to +100 °C		–25 °C up to +90 °C	
Plug connection	M8-plug		M8-plug	
LED	no		Voltage (green) Function display (yellow)	
Cable, length of cable			PUR, 5 m	
Output (interlock)	pnp	nnp	pnp	nnp
Part no. (1 off)	3829-234	3829-240	3829-099	3829-124

Further accessory

see data sheet G 2.140

- Pin-and-socket connector
- Y-distributor
- Reversing plug
- Voltage regulator
- Straight tube male stud coupling with elastic sealing

Note:

Electronic magnetic sensors for an environmental temperature of +120 °C or with short path are available on request.

Type L

D 8 L ED for tube Ø 8 G 1/4 250 bar
D 15 L ED for tube Ø 15 G 1/2 250 bar

Part no.

9208-131
9215-033

Type S

D 8 S ED for tube Ø 8 G 1/4 500 bar
D 16 S ED for tube Ø 16 G 1/2 500 bar

Part no.

9208-132
9216-021



Other fittings see data sheet F 9.300