

## 4/3-way servo solenoid directional control valves, pilot operated, with electrical position feedback and on-board electronics

**RE 29089/01.09**  
Replaces: 01.05

**Type 4WRLE 10...35, symbols E./W.**

Sizes (NG) 10, 16, 25, 27, 35  
Unit series 3X  
Maximum working pressure P, A, B 350 bar (NG27: 280 bar)  
Nominal flow rate 50...1100 l/min ( $\Delta p = 10$  bar)

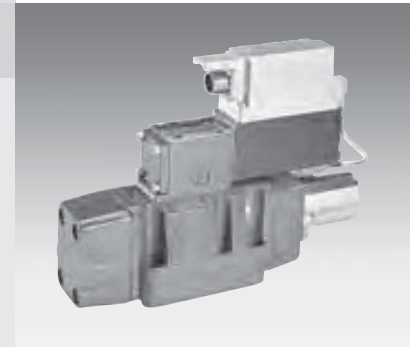

### List of contents

Contents	Page
Features	1
Ordering data	2
Accessories, function, sectional diagram	3
Control oil supply	4
Technical data	5 to 7
On-board electronics	8
Characteristic curves	9 to 11
Unit dimensions	12 to 15

### Features

- Pilot operated 4/3-way servo solenoid directional control valves NG10 to NG35, with approx. 20% overlap
- Pilot valve NG6, with control piston and sleeve in servo quality, actuated on one side, 4/4 fail-safe position when switched off
- Control solenoid with electrical position feedback and on-board electronics (OBE), calibrated at the factory
- Main stage with position feedback
- Electronically calibrated and compensated overlap
- Spool with linear travel, with anti-rotation element
- Flow characteristic
  - S = Progressive
  - NG16, 25 and 27 with load tap C1/C2
- For subplate attachment, mounting hole configuration NG10 to ISO 4401-05-05-0-05, NG16 to ISO 4401-07-07-0-05, NG25/27 to ISO 4401-08-08-0-05 and NG35 to ISO 4401-10-09-0-05
- Subplates as per Technical Data Sheet, NG10 RE 45055, NG16 RE 45057, NG25/27 RE 45059 and NG35 RE 45060 (order separately)
- Plug-in connectors to DIN 43563-AM6, see Technical Data Sheet RE 08008 (order separately)



## Ordering data

4WRL	E				S	J	3X/G24	K0/A1	M	*
With on-board electronics = E										
NG10	= 10									
NG16	= 16									
NG25	= 25									
NG27 <sup>1)</sup>	= 27									
NG35 <sup>2)</sup>	= 35									
Control spool symbols = E, E1										
= E (Z), E1 (Z)										
= W, W1										
= W (Z), W1 (Z)										
= E4										
= W4										
<input type="checkbox"/>	Transitional symbols									
With symbol E1, E1(Z), E4, W1(Z), W4:										
P → A: $q_v$ B → T: $q_v/2$										
P → B: $q_v/2$ A → T: $q_v$										
With load tap C1/C2 (NG16, 25, 27) = Z										
		Further information in plain text								
		M = NBR seals, suitable for mineral oils (HL, HLP) to DIN 51524								
		Interface for trigger electronics								
		A1 = Setpoint input ±10 V								
		Electrical connection								
		K0 = without plug-in connector, with plug to DIN 43563-AM6								
		Order plug-in connector separately								
		Control oil supply "x", control oil return "y"								
		No desig. = "x" = external, "y" = external								
		E = "x" = internal, "y" = external								
		ET = "x" = internal, "y" = internal								
		T = "x" = external, "y" = internal								
		Voltage supply of trigger electronics								
		G24 = +24 V DC								
		3X = Unit series 30 to 39 (installation and connection dimensions unchanged)								
		J = Overlap compensation signal								
		See characteristic curve range: +0.5 V								
		Flow characteristic								
		S = Progressive								
		Nominal flow rate at 10 bar valve pressure difference (5 bar per metering notch)								
		NG10								
		50 = 50 l/min								
		80 = 80 l/min								
		NG16								
		180 = 180 l/min								
		NG25								
		350 = 350 l/min								
		NG27								
		430 = 430 l/min <sup>1)</sup>								
		NG35								
		1100 = 1100 l/min <sup>2)</sup>								

<sup>1)</sup> NG27 is a high-flow version of NG25, ports P, A, B and T have  $\varnothing$  32 mm in the main stage. Contrary to standard ISO 4401-08-08-0-05, ports P, A, B and T may be drilled to max.  $\varnothing$  30 mm in the control block. These valves therefore offer higher flow rates  $Q_A : Q_B$

<sup>2)</sup> NG35 is a high-flow version of NG32, ports P, A, B and T have  $\varnothing$  50 mm in the main stage. Contrary to standard ISO 4401-10-09-0-05, ports P, A, B and T may be drilled to max.  $\varnothing$  48 mm in the control block. These valves therefore offer higher flow rates  $Q_A : Q_B$

## Accessories, not included in delivery

	NG10	4 x ISO 4762-M6 x 40-10.9-N67F821 70	2 910 151 209
	NG16	2 x ISO 4762-M6 x 45-10.9-N67F821 70	2 910 151 211
		4 x ISO 4762-M10 x 50-10.9-N67F821 70	2 910 151 301
	NG25/27	6 x ISO 4762-M12 x 60-10.9-N67F821 70	2 910 151 354
	NG35	6 x ISO 4762-M20 x 90-10.9-N67F821 70	2 910 151 532
	Plug-in connectors 6P+PE, also see RE 08008	KS	1 834 482 022
		KS	1 834 482 026
		MS	1 834 482 023
		MS	1 834 482 024
		KS 90°	1 834 484 252

## Testing and service equipment

– Test box type VT-PE-TB3, see RE 30065

– Test adapter 6P+PE type VT-PA-2, see RE 30068

## Function, sectional diagram

### Construction

The valve consists of three main assemblies:

- Pilot valve (1) with control spool and sleeve, return springs, control solenoid and inductive position transducer
- Main stage (2) with centering springs and position feedback
- On-board trigger electronics (3)

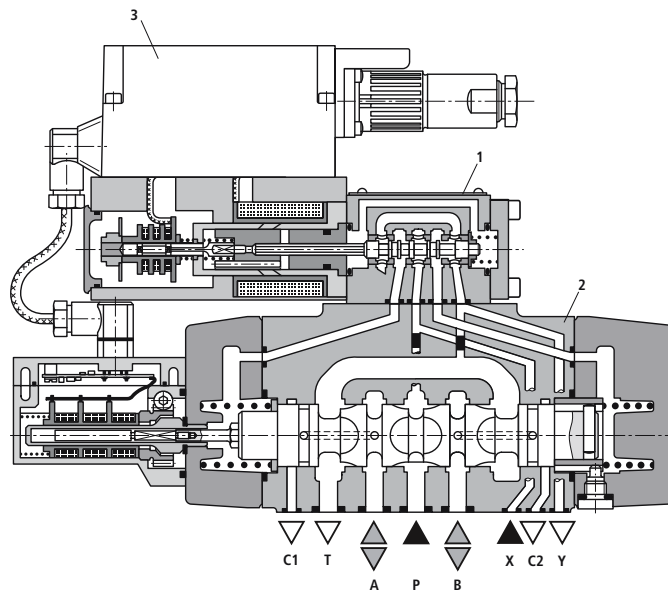

### Functional description

When the control solenoid is not actuated, the control spool is held by springs in the fail-safe position, and the main stage spool remains in its spring-centered mid position.

In the on-board electronics, the pre-defined setpoint is compared with the actual value for the position of the main stage control spool. In the event of an error signal, the control solenoid is actuated, and the pilot spool is moved as the magnetic force changes. The flow released through the control cross-sections causes the main control spool to move. The spool stroke is controlled proportionately to the setpoint of 0.5...10 V between 20...100%. If the input setpoint is  $\leq \pm 0.5$  V, the control spool is held in the spring-centered, overlapped mid position.

The control oil is conveyed to the pilot valve either internally via port P or externally via port X. The oil returns to the tank internally via port T or externally via port Y.

### Power failure

In the event of a power failure or an open circuit, the on-board electronics cut off the electricity to the control solenoid and the pilot spool moves to the fail-safe position, relieving the control oil chambers of the main stage. The main stage control spool is held by springs in mid position.

## Control oil supply

The pilot valve can be supplied both via ports X and Y (externally) and via the main flow channels P and T.

NG10, 25, 27, 35

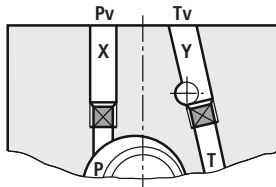

NG16

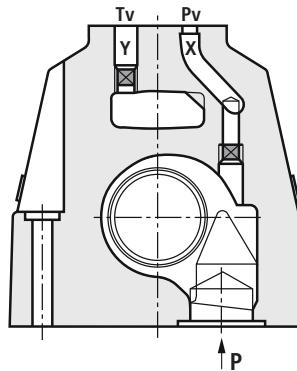

Type...-3X...

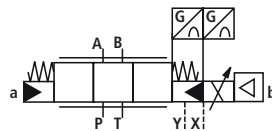

Type...-3X...E...

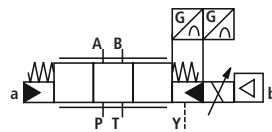

Type...-3X...ET...

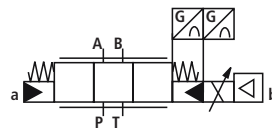

Type...-3X...T...

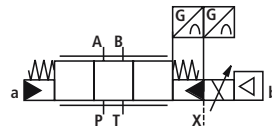

Symbol in detail  
(external control oil inlet and outlet)

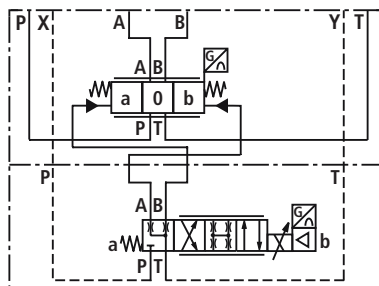

Main valve

Pilot valve

<b>No designation =</b>	"x" = external	"y" = external
<b>E =</b>	"x" = internal	"y" = external
<b>ET =</b>	"x" = internal	"y" = internal
<b>T =</b>	"x" = external	"y" = internal

## Technical data

### General

Construction	Spool type valve, pilot operated					
Actuation	Servo solenoid directional control valve NG6, with position controller for pilot valve and main stage					
Type of mounting	Subplate, mounting hole configuration NG10...35 to ISO 4401-...					
Installation position	Optional					
Ambient temperature range	°C -20...+50					
Weight	kg	<b>NG10</b> 8.7	<b>NG16</b> 10.6	<b>NG25</b> 18.4	<b>NG27</b> 18.4	<b>NG35</b> 81
Vibration resistance, test condition	Max. 25 g, shaken in 3 dimensions (24 h)					

### Hydraulic (measured with HLP 46, $\vartheta_{oil} = 40\text{ °C} \pm 5\text{ °C}$ )

Pressure fluid	Hydraulic oil to DIN 51524...535, other fluids after prior consultation					
Viscosity range	recommended	mm <sup>2</sup> /s 20...100				
	max. permitted	mm <sup>2</sup> /s 10...800				
Pressure fluid temperature range	°C -20...+70					
Maximum permissible degree of contamination of pressure fluid	Class 18/16/13 <sup>1)</sup>					
Purity class to ISO 4406 (c)	Class 18/16/13 <sup>1)</sup>					
Flow direction	See symbol					
Nominal flow at		<b>NG10</b>	<b>NG16</b>	<b>NG25</b>	<b>NG27</b>	<b>NG35</b>
$\Delta p = 5\text{ bar}$ per notch <sup>2)</sup>	l/min	50, 80	180	350	430	1100
Max. working pressure	Ports P, A, B (external control oil inlet)	350	350	350	280	350
	Ports P, A, B, X	280				
	Ports T, Y	250				
Min. control oil pressure in "pilot stage"	bar	8				
$Q_{max}$	l/min	170	450	900	1000	3500
$Q_N$ pilot valve (inlet)						
$\Delta p = 35\text{ bar}$	l/min	2	4	12	12	40
Leakage of pilot valve at X = 100 bar	cm <sup>3</sup> /min	<150	<180	<350	<500	<1100
Leakage of main stage control spool symbols "E" at P = 100 bar	l/min	<0.25	<0.4	<0.6	<0.6	<1.1

### Static/Dynamic

Overlap in mid position	≈18...22% of spool stroke, electrically compensated for $U_{D-E} \pm 0.5\text{ V}$					
Spool stroke, main stage	± mm	4	7	10	10	12,5
Control oil volume of main stage 100%	cm <sup>3</sup>	1.1	4.3	11.3	11.3	41.5
Control oil requirement 0...100%, (at X = 100 bar)	l/min	2.2	4.7	11.7	11.7	15.6
Hysteresis	%	<0.1, scarcely measurable				
Manufacturing tolerance	%	<±5 ( $Q_{max}$ )				
Response time for 0...100%, (at X = 100 bar)	ms	<40	<80	<80	<80	<130
Response time for 0...100%, (at X = 10 bar)	ms	<150	<250	<250	<250	<500
Switch-off behavior	After electrical switch-off (pilot valve in fail-safe) Main stage moves to spring-centered overlapped mid position					
Thermal drift	<1% at $\Delta T = 40\text{ °C}$					
Calibration	At the factory ±1%, see flow curve					
Electromagnetic compatibility	EN 61000-6-2: 2002-08 EN 61000-6-3: 2002-08					

<sup>1)</sup> The purity classes stated for the components must be complied with in hydraulic systems. Effective filtration prevents problems and also extends the service life of components. For a selection of filters, see Technical Data Sheets RE 50070, RE 50076 and RE 50081.

<sup>2)</sup> Flow rate at a different  $\Delta p$   $Q_x = Q_{nom} \cdot \sqrt{\frac{\Delta p_x}{5}}$

## Technical data

### Electric pilot valve NG6, trigger electronics integrated in the valve

Cyclic duration factor	%	100 ED
Degree of protection		IP 65 to DIN 40050 and IEC 14434/5
Connection		Plug-in connector 6P+PE, DIN 43563
Power supply		24 V DC <sub>nom</sub>
Terminal A:		min. 21 V DC/max. 40 V DC
Terminal B: 0 V		Ripple max. 2 V DC
Power consumption		Solenoid $\square$ 45 mm = 40 VA max.
External fuse		2,5 A <sub>F</sub>
Input, "Standard" version		Differential amplifier, $R_i = 100 \text{ k}\Omega$
Terminal D: $U_E$		0...±10 V
Terminal E:		0 V
Max. differential input voltage at 0 V		D → B } max. 18 V DC E → B }
Test signal, "Standard" version		LVDT
Terminal F: $U_{\text{Test}}$		0...±10 V
Terminal C:		Reference 0 V
Protective conductor and screen		See pin assignment
Recommended cable		See pin assignment up to 20 m 7 x 0.75 mm <sup>2</sup> up to 40 m 7 x 1 mm <sup>2</sup>
Calibration		Overlap and P-A at +8 V, calibrated at the factory, see valve characteristic curve

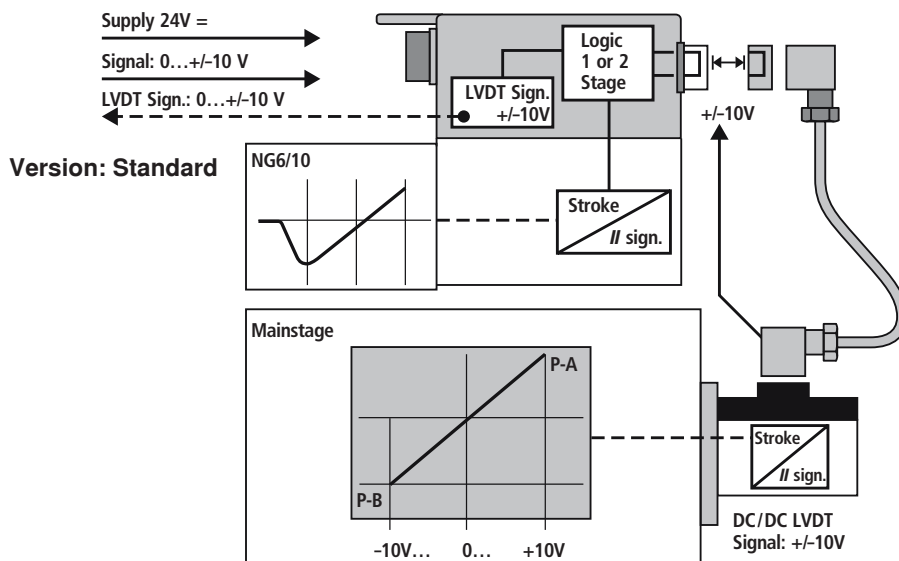

### Important

Pilot operated 4/3-way servo solenoid directional control valves with positive overlap perform their function in open or closed-loop-controlled axes and have approx. 20 % overlap when switched off.

This condition does not constitute an active fail-safe position. For this reason, many applications require the use of "external check valves" or certain sandwich-mounted valves, which must be taken into account during the On/Off switching sequence.

## Connection

For electrical data, see page 6

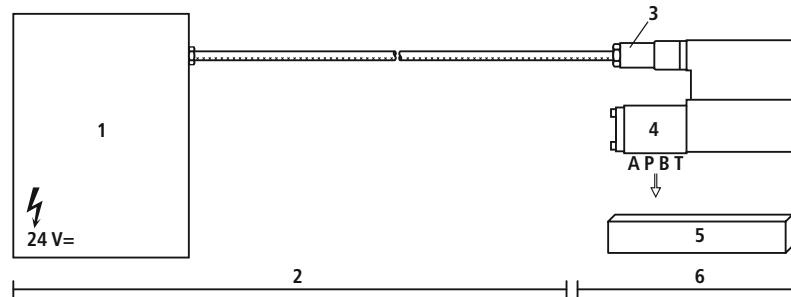

- 1 Control
- 2 Provided by customer
- 3 Plug-in connector
- 4 Valve
- 5 Connecting surface
- 6 Provided by Rexroth

### Technical notes on the cable

- Version:**
- Multi-wire cable
  - Extra-finely stranded wire to VDE 0295, Class 6
  - Protective conductor, green/yellow
  - Cu braided screen
- Types:**
- e.g. Ölflex-FD 855 CP (from Lappkabel company)
- No. of wires:**
- Determined by type of valve, plug type and signal assignment
- Cable Ø:**
- 0.75 mm<sup>2</sup> to 20 m length
  - 1.0 mm<sup>2</sup> to 40 m length
- Outside Ø:**
- 9.4...11.8 mm – Pg11
  - 12.7...13.5 mm – Pg16

### Important

Voltage supply 24 V DC<sub>nom.</sub>  
if voltage drops below 18 V DC, rapid shutdown resembling "Enable OFF" takes place internally.  
In addition, with the "mA signal" version:  
 $I_{D-E} \geq 3 \text{ mA}$  – valve is active  
 $I_{D-E} \leq 2 \text{ mA}$  – valve is deactivated.  
Electrical signals emitted via the trigger electronics (e.g. actual values) must not be used to shut down safety-relevant machine functions! (See European Standard, "Technical Safety Requirements for Fluid-Powered Systems and Components – Hydraulics", EN 982.)

## On-board electronics

### Block diagram/pin assignment

Version A1:  $U_{D-E} \pm 10\text{ V}$

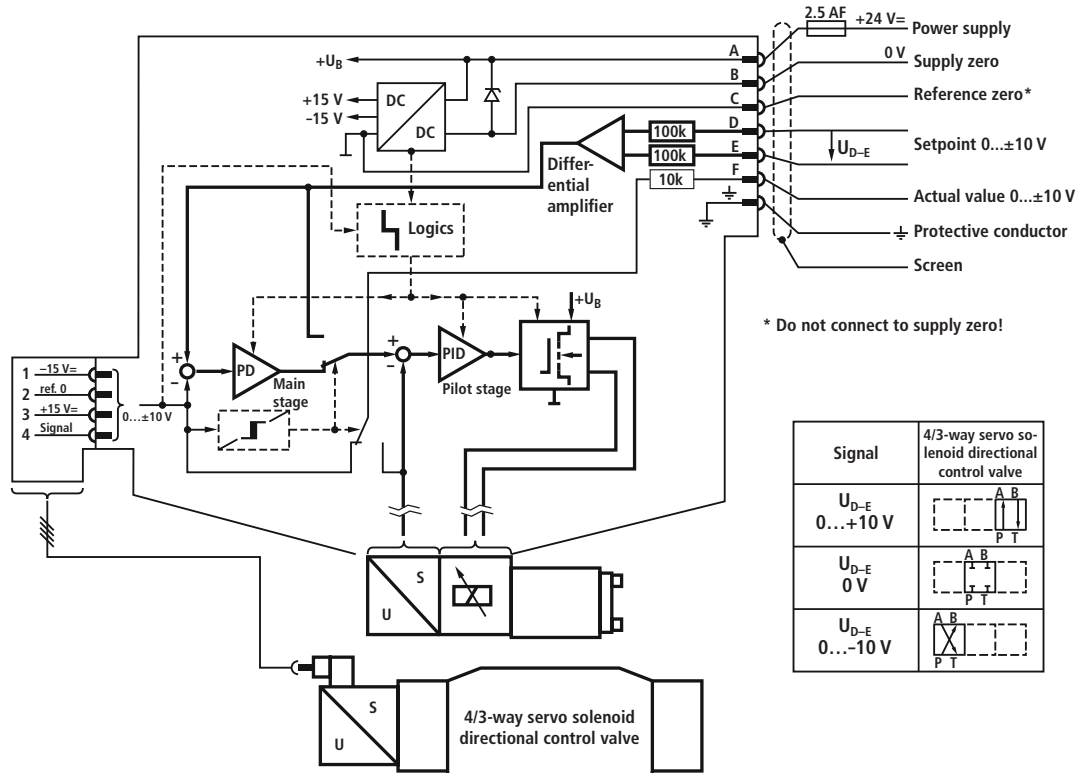

### Pin assignment 6P+PE

Version A1:  $U_{D-E} \pm 10\text{ V}$   
( $R_i = 100\text{ k}\Omega$ )

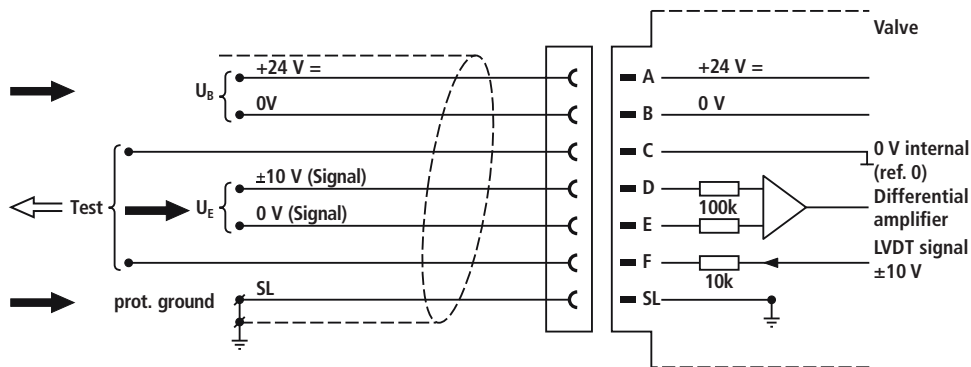

## Characteristic curves (measured with HLP 46, $\vartheta_{oil} = 40^\circ\text{C} \pm 5^\circ\text{C}$ )

### Flow rate – signal function

$$Q = f(U_{D-E})$$

Symbol E(Z), W(Z) ( $Q_A:Q_B = 1:1$ )  
E1(Z), W1(Z) ( $Q_A:Q_B = 2:1$ )

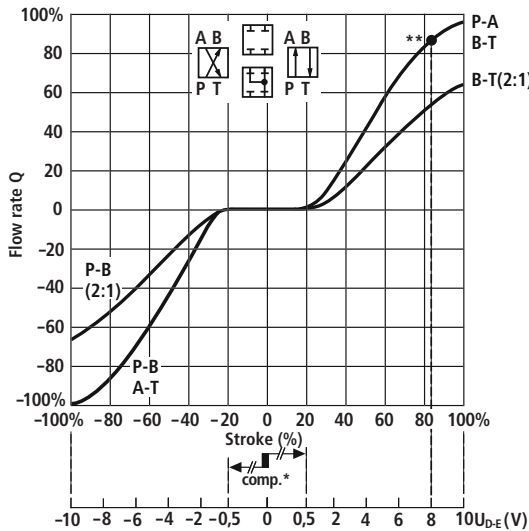

### Control spool with asymmetric metering notches

Control spools with asymmetric metering notches are available in a ratio of 2:1 for the purpose of adaptation to differential cylinders.

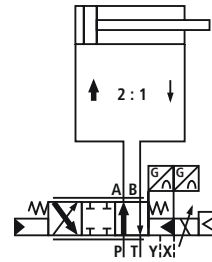

### Flow in mid position, "leakage oil pressure relief"

With symbol "E", leakage oil in the two work chambers A and B of the control piston gives rise to a build-up of pressure in A or B, which then causes a connecting cylinder to drift out of position.

In many cases, the "W" symbol is a better solution. With a setpoint of "0", the control piston moves into the overlapped mid position. In this mid position, pressure is then relieved from ports A and B with  $1\% \pm 0.5\% Q_N$  to T. This also supports the function of external check valves.

Symbol E4, W4 ( $Q_A:Q_B = 2:1$ )

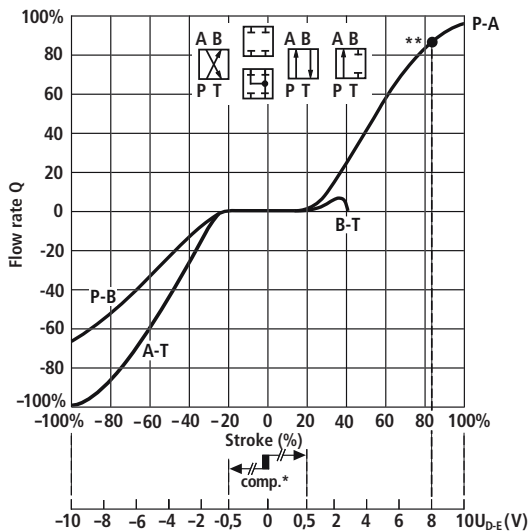

### Control spools in a differential circuit

In order to produce differential circuits, valve spools with a 4th position are available.

It is sufficient to install a check valve in the consumer lines.

In addition, a control spool (symbol) with internal B-P connection is employed for certain branch-oriented solutions. However, we recommend that you consult the BRH Application Center with regard to these special symbols, as a simulation or knowledge of this type of system is usually required.

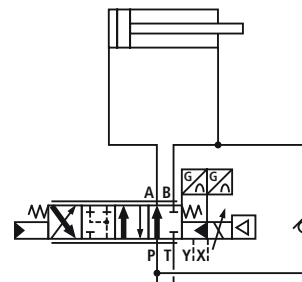

\* Comp.  $U_{D-E} \pm 0.5\text{ V}$  factory setting  $\pm 1\%$

\*\*  $Q_{P-A}$  at  $+8\text{ V}$  [ $U_{D-E}$ ] manufacturing tolerance  $Q_{max} \leq \pm 5\%$

## Characteristic curves (measured with HLP 46, $\vartheta_{oil} = 40\text{ }^{\circ}\text{C} \pm 5\text{ }^{\circ}\text{C}$ )

### Load tap C1/C2

To compensate for fluctuations in the load or supply pressure, 4/3-way servo solenoid directional control valves are combined with pressure compensators. The load is tapped via a shuttle valve for the NG10 and 35, and via two additional ports C1 and C2 for the NG16, 25 and 27.

The pressure compensator therefore always receives the correct pressure signal even in the event of negative load. When using pressure compensators, an external control oil supply should always be selected.

### NG10, 35

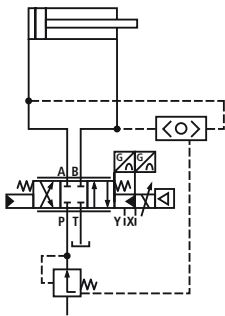

### NG16, 25, 27

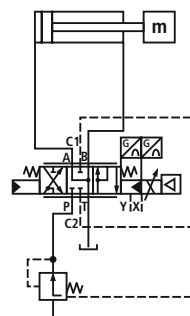

## Characteristic curves (measured with HLP 46, $\vartheta_{oil} = 40^\circ\text{C} \pm 5^\circ\text{C}$ )

Response time (at X = 100 bar)

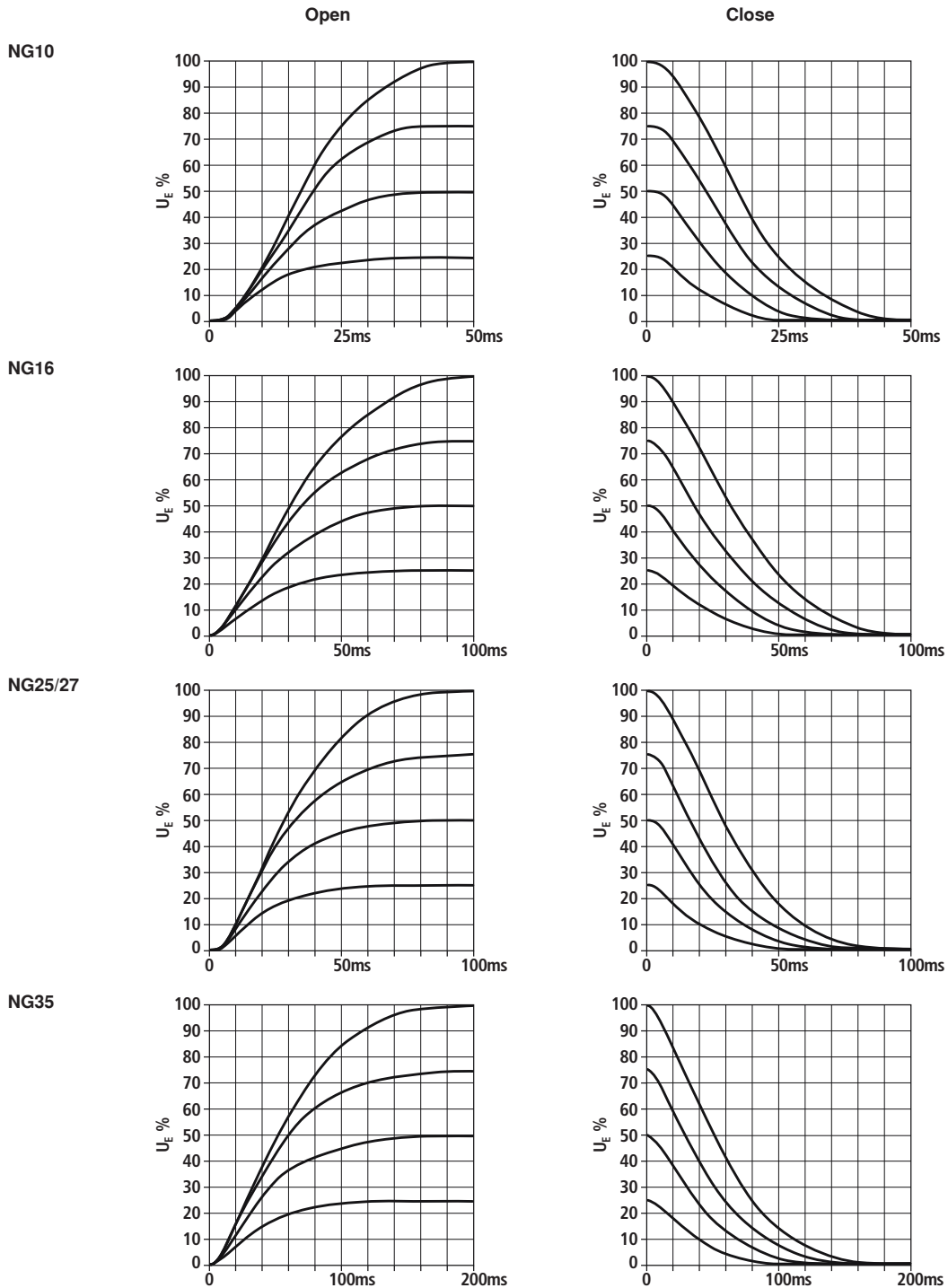

## Unit dimensions NG10 (nominal dimensions in mm)

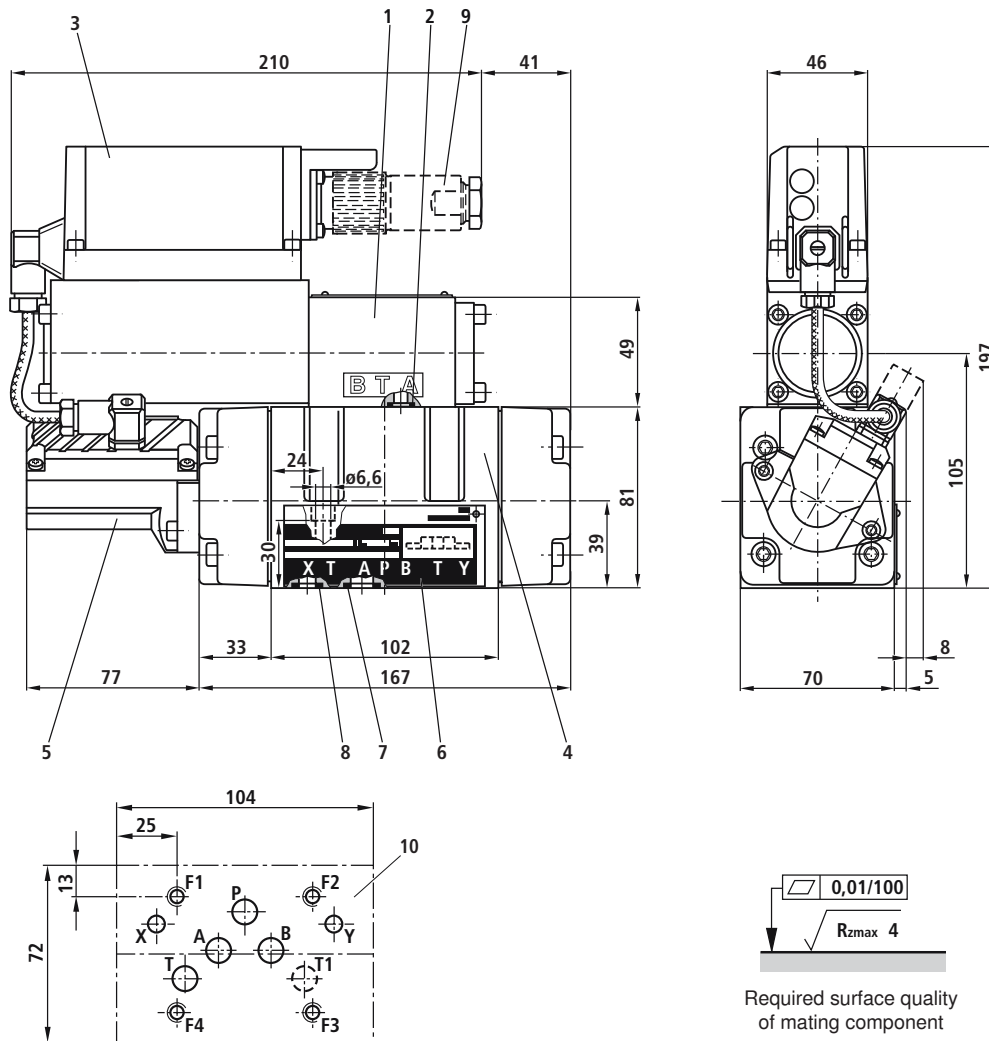

- 1 Pilot valve
- 2 O-ring 9.25 x 1.78 (ports P, A, B, T)
- 3 On-board electronics
- 4 Main valve
- 5 Inductive position transducer (main valve)
- 6 Nameplate
- 7 O-ring 12 x 2 (ports P, A, B, T, T1)
- 8 O-ring 10 x 2 (ports X, Y)
- 9 Plug-in connector not included in delivery (order separately)

- 10 Machined valve contact surface, mounting hole configuration according to ISO 4401-05-05-0-05  
Deviates from standard:  
Ports P, A, B, T, T1  $\varnothing$  10,5 mm  
Minimum thread depth: Ferrous metal 1.5 x  $\varnothing$   
Non-ferrous 2 x  $\varnothing$

**Subplates**, see Technical Data Sheet RE 45055

**Valve fastening bolts** (order separately)

The following valve fastening bolts are recommended:

**4 cheese-head bolts ISO 4762-M6x40-10.9-N67F821 70**  
(galvanized in accordance with Bosch standard N67F821 70)  
Tightening torque  $M_A = 11 \pm 3$  Nm

Material no. **2910151209**

## Unit dimensions NG16 (nominal dimensions in mm)

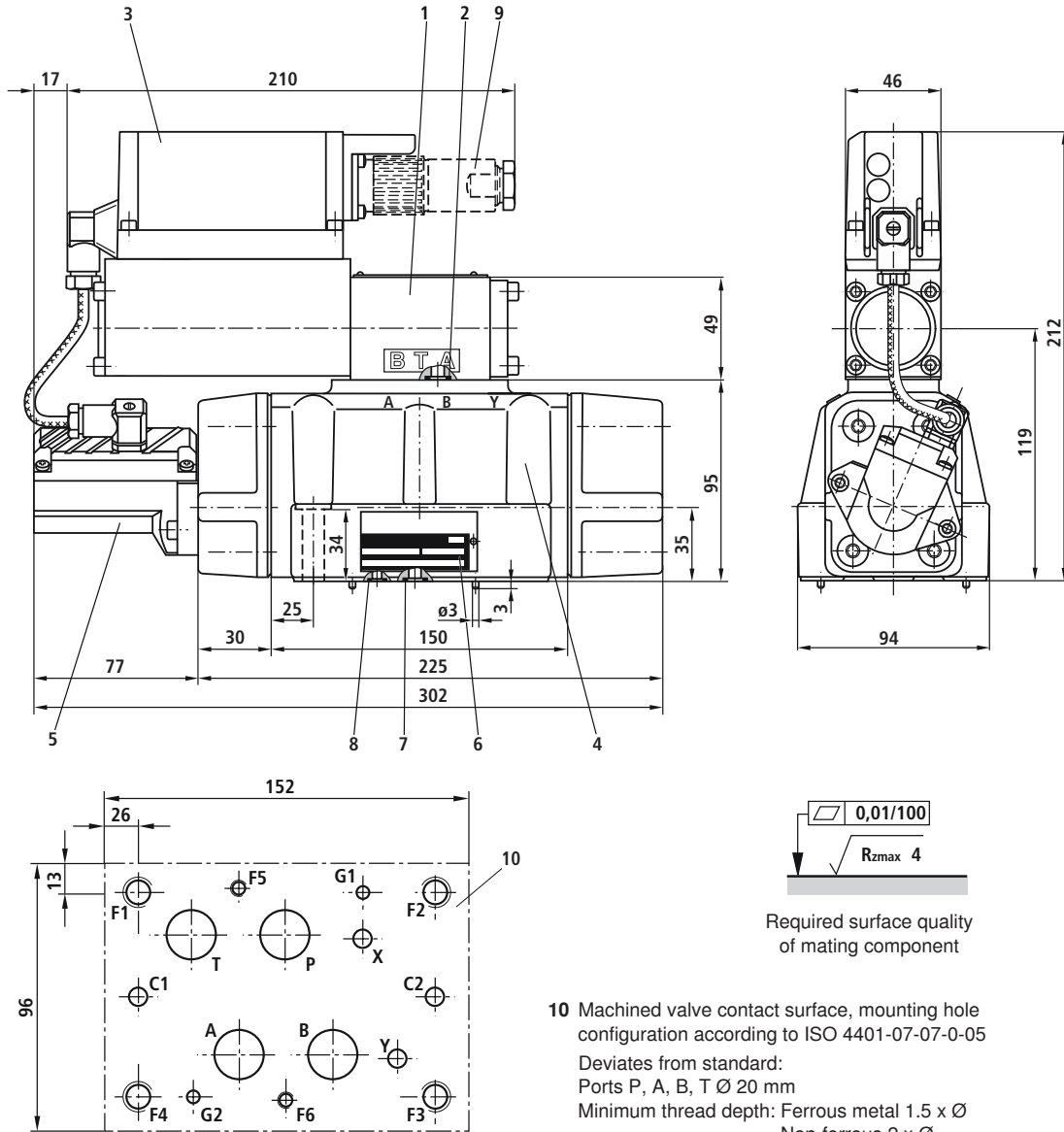

- 1 Pilot valve
- 2 O-ring 9.25 x 1.78 (ports P, A, B, T)
- 3 On-board electronics
- 4 Main valve
- 5 Inductive position transducer (main valve)
- 6 Nameplate
- 7 O-ring 23 x 2.5 (ports P, A, B, T)
- 8 O-ring 9 x 2 (ports X, Y, C1, C2)
- 9 Plug-in connector not included in delivery (order separately)

- 10 Machined valve contact surface, mounting hole configuration according to ISO 4401-07-07-0-05  
Deviates from standard:  
Ports P, A, B, T  $\varnothing$  20 mm  
Minimum thread depth: Ferrous metal 1.5 x  $\varnothing$   
Non-ferrous 2 x  $\varnothing$

**Subplates**, see Technical Data Sheet RE 45057

**Valve fastening bolts** (order separately)

The following valve fastening bolts are recommended:

**2 cheese-head bolts ISO 4762-M6x45-10.9-N67F821 70**  
(galvanized in accordance with Bosch standard N67F821 70)  
Tightening torque  $M_A = 11+3$  Nm

Material no. **2910151211**

**4 cheese-head bolts ISO 4762-M10x50-10.9-N67F821 70**  
(galvanized in accordance with Bosch standard N67F821 70)  
Tightening torque  $M_A = 50+10$  Nm

Material no. **2910151301**

## Unit dimensions NG25/27 (nominal dimensions in mm)

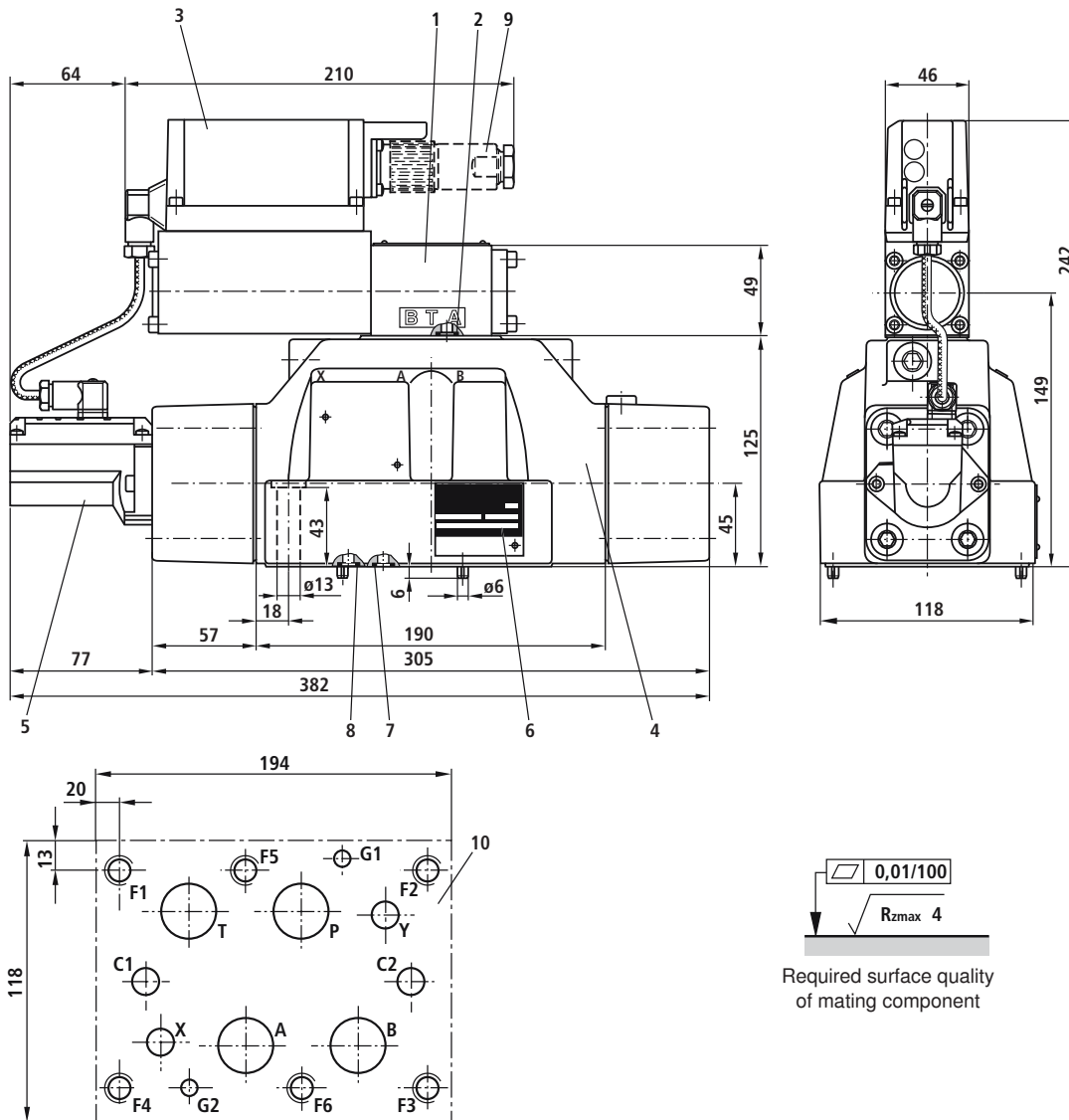

- 1 Pilot valve
- 2 O-ring 9.25 x 1.78 (ports P, A, B, T)
- 3 On-board electronics
- 4 Main valve
- 5 Inductive position transducer (main valve)
- 6 Nameplate
- 7 O-ring (ports P, A, B, T)  
NG25: 28 x 3  
NG27: 34.6 x 2.62
- 8 O-ring 15 x 2.5 (ports X, Y, C1, C2)
- 9 Plug-in connector not included in delivery (order separately)

- 10 Machined valve contact surface, mounting hole configuration according to ISO 4401-08-08-0-05  
Deviates from standard:  
NG25: Ports P, A, B, T  $\varnothing$  25 mm  
NG27: Ports P, A, B, T  $\varnothing$  32 mm  
Minimum thread depth: Ferrous metal 1.5 x  $\varnothing$   
Non-ferrous 2 x  $\varnothing$

**Subplates**, see Technical Data Sheet RE 45059

**Valve fastening bolts** (order separately)

The following valve fastening bolts are recommended:

**6 cheese-head bolts ISO 4762-M12x60-10.9-N67F82170**  
(galvanized in accordance with Bosch standard N67F82170)  
Tightening torque NG25  $M_A = 90+30$  Nm,  
NG27  $M_A = 90\pm 15$  Nm

Material no. **2910151354**

## Unit dimensions NG35 (nominal dimensions in mm)

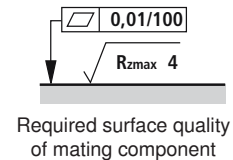
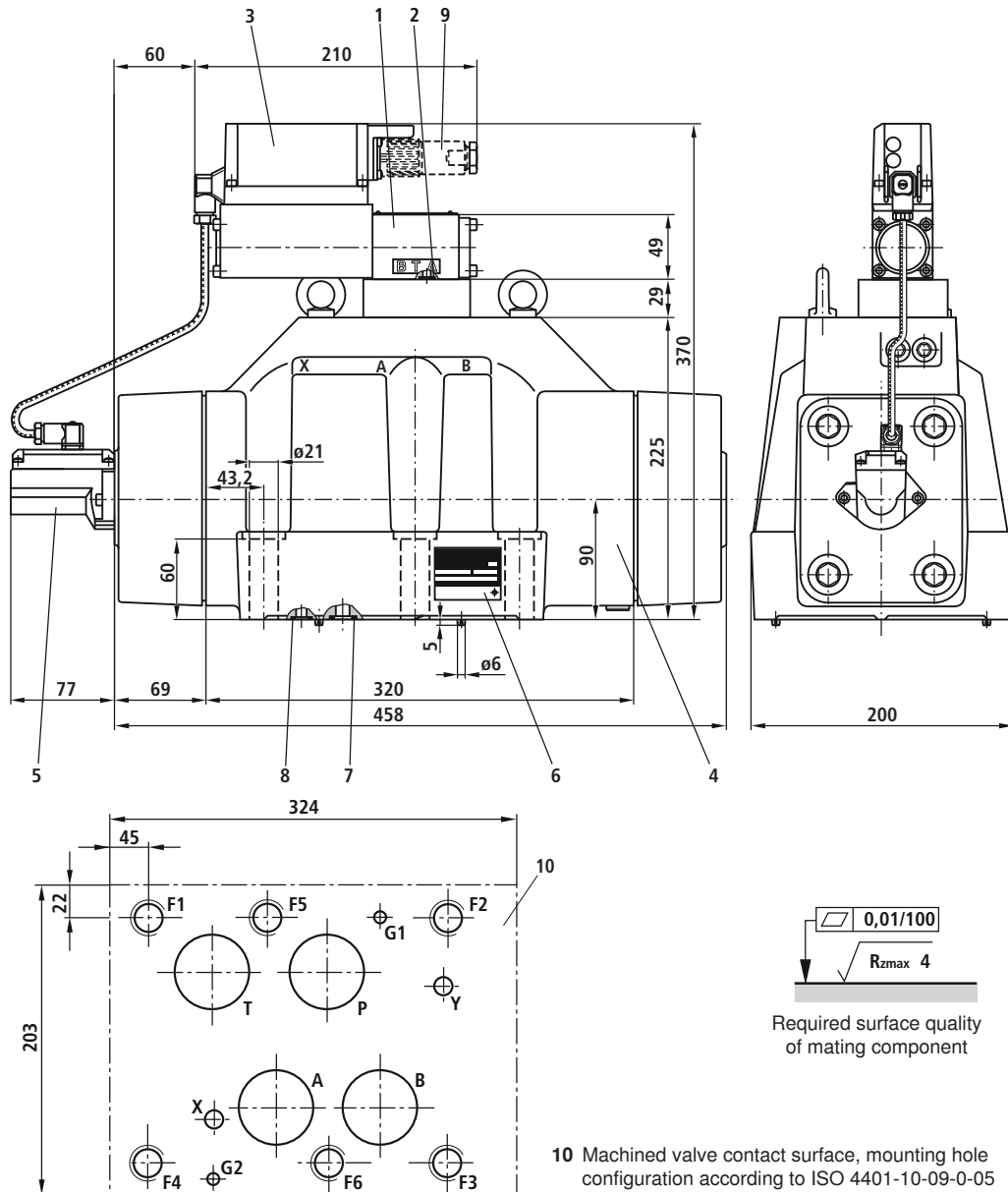

- 1 Pilot valve
- 2 O-ring 9.25 x 1.78 (ports P, A, B, T)
- 3 On-board electronics
- 4 Main valve
- 5 Inductive position transducer (main valve)
- 6 Nameplate
- 7 O-ring 53.57 x 3.53 (ports P, A, B, T)
- 8 O-ring 15 x 2.5 (ports X, Y)
- 9 Plug-in connector not included in delivery (order separately)

- 10 Machined valve contact surface, mounting hole configuration according to ISO 4401-10-09-0-05  
Deviates from standard:  
Ports P, A, B, T  $\phi 48$  mm  
Minimum thread depth: Ferrous metal 1.5 x  $\phi$   
Non-ferrous 2 x  $\phi$

**Subplates**, see Technical Data Sheet RE 45060

**Valve fastening bolts** (order separately)

The following valve fastening bolts are recommended:

**6 cheese-head bolts ISO 4762-M20x90-10.9-N67F821 70**  
(galvanized in accordance with Bosch standard N67F821 70)  
Tightening torque  $M_A = 450 + 110$  Nm

Material no. **2910151532**

## Notes

---

© This document, as well as the data, specifications and other information set forth in it, are the exclusive property of Bosch Rexroth AG. It may not be reproduced or given to third parties without its consent.  
The data specified above only serve to describe the product. No statements concerning a certain condition or suitability for a certain application can be derived from our information. The information given does not release the user from the obligation of own judgment and verification. It must be remembered that our products are subject to a natural process of wear and aging.