

Electric Drives  
and Controls

Hydraulics

Linear Motion and  
Assembly Technologies

Pneumatics

Service

**Rexroth**  
Bosch Group

## Axial Piston Variable Pump A2VK

**RE 94001/06.10** 1/12  
Replaces: 07.04

### Data sheet

Size 12 to 107  
Series 1 and 4  
Nominal pressure 250 bar  
Maximum pressure 315 bar  
Version for pumping plastic components

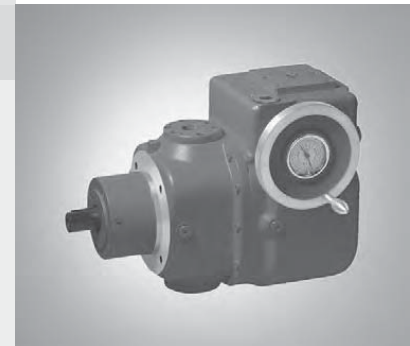

### Contents

Ordering code for standard program	2
Technical data	3
Dimensions size 12	5
Dimensions size 28	6
Dimensions size 55	7
Dimensions size 107	8
Pressure limiting valve attached	9
General instructions	12

### Features

- Variable axial piston pump for pumping and metering polyurethane components
- High metering accuracy and reproducibility of the variable pumped volumes
- Robust manual adjustment via handwheel with integral precision measuring scale
- Operating pressure up to 250 bar
- Low pulsation of the pumped medium
- Pump components are compatible with the pumped media (polyol, isocyanate) due to special pairings of materials and sealing elements
- Low-noise
- Excellent volumetric efficiency for high metering accuracy
- Double shaft seals with buffer fluid ports to guarantee safe operation (and protect the environment)
- With corrosion protection

### Note

Size 12 and 28 are in the phase-out program.  
Replacement product is the A7VK, see RE 94010.

## Ordering code for standard program

	A2VK		MA			G	P	E		-	SO2
--	------	--	----	--	--	---	---	---	--	---	-----

**Axial piston unit**

Variable pump A2VK

**Size**

$\triangleq$ Displacement $V_{g \max}$ in $\text{cm}^3$	12	28	55	107
	▲	▲	●	●

**Control device**

Manual adjustment MA

**Operating mode**

Open circuit	O
Closed circuit	G

**Direction of rotation**

Looking onto drive shaft	clockwise	R
	anti-clockwise	L

**Series**

	Size 28-107	1
	Size 12	4

**Model**

Enclosed pump G

**Valve attachment**

Without valve attached	0
Pressure limiting valve attached	1

**Drive shaft**

Cylindrical with key P

**Swivel angle**

One-sided E

**Handwheel assembly version**

Looking onto drive shaft	left side	1
	right side	2

**Corrosion-protected version**

SO2

● = Available    ▲ = Phase-out program

## Technical data

### Fluid

The pump pumps and meters fluids for manufacturing polyurethane (polyol and isocyanate components).

### Operating viscosity range

The following limit conditions apply:

$v_{\min}$  \_\_\_\_\_ 1 mm<sup>2</sup>/s,

$v_{\max}$  \_\_\_\_\_ 2000 mm<sup>2</sup>/s

Please contact us if higher values are required.

### Operating temperature range

Optimum operating temperature range  $t$  \_\_\_\_\_ 10-50°C

Maximum operating temperature  $t_{\max}$  \_\_\_\_\_ 80°C

The permitted working temperature depends on the lubricity of the fluid. The maximum fluid temperature must not be exceeded even locally (e.g. no more than 5K over the leakage fluid temperature).

### Filtering the fluid

The filter should be arranged so that only filtered fluid enters the pump. The finer the filter, the longer the service life of your axial piston pump.

We recommend a filter grade  $\eta_{\text{abs.}} \leq$  \_\_\_\_\_ 125  $\mu\text{m}$

### Operating pressure range

#### Input

Open circuit:

Max. filling pressure at the port S  $p_{\max \text{ abs.}}$  \_\_\_\_\_ 10 bar

Min. filling pressure at the port S  $p_{\min \text{ abs.}}$  \_\_\_\_\_ 1 bar

The pump must always be filled completely.

Closed circuit:

Leakage fluid pressure  $p_{\max \text{ abs.}}$  \_\_\_\_\_ 10 bar

Max. intermittent cumulative pressure A + B  $p_{\max}$  \_\_\_\_\_ 250 bar

#### Output

Maximum pressure at port A or B  
(pressure data according to DIN 24312)

Nominal pressure  $p_N$  \_\_\_\_\_ 250 bar

Maximum pressure  $p_{\max}$  \_\_\_\_\_ 315 bar

### Leakage fluid

Max. leakage fluid pressure  $p_{L \max}$  \_\_\_\_\_ 10 bar

*In the closed circuit*, pump ports A and B are separated from the housing space. The leakage fluid must be removed via port T<sub>1</sub> or T<sub>2</sub> using a separate line.

*In the open circuit*, the suction port S is connected to the housing space. There is no need for a line for the leakage fluid. Ports T<sub>1</sub> and T<sub>2</sub> are plugged. The filling pressure at port S acts on the shaft sealing ring via the housing space.

The service life of the shaft sealing ring decreases as the pressure of the leakage fluid or the filling pressure at port S increases.

### Through put flow

Swivel direction	Direction of rotation "clockwise"		Direction of rotation "anti-clockwise"	
	open circuit	closed circuit	open circuit	closed circuit
clockwise	<b>S to B</b> <b>A plugged</b>	<b>A to B</b>	<b>S to A</b> <b>B plugged</b>	<b>B to A</b>
anti-clockwise	<b>S to A</b> <b>B plugged</b>	<b>B to A</b>	<b>S to B</b> <b>A plugged</b>	<b>A to B</b>

### Installation position

Any. The pump must be completely filled with fluid. If installed with the shaft pointing upwards, the top leakage fluid port must be connected to the housing for both types of circuit to ensure that the housing is vented in the vicinity of the bearing.

Preferred installation position: drive shaft horizontal

The adjustment display in the handwheel can only be guaranteed to work if the adjusting spindle is installed -30° to +30° from the horizontal.

## Technical data

### Table of values

Size			12	28	55	107	
Displacement	$V_{g\ max}$	cm <sup>3</sup>	11.6	28.1	54.8	107	
Flow <sup>1)</sup> at speed n	$q_{v\ max}$	n = 735 rpm	l/min	8.3	20	39.1	76.3
		n = 970 rpm	l/min	10.9	26.4	51.6	100.7
		n = 1450 rpm	l/min	16.3	39.5	77.1	150.5
		n = 1800 rpm	l/min	20.3	49.1	95.7	186.8
Power at $\Delta p = 250$ bar and speed n	$P_{max}$	n = 735 rpm	kW	3.4	8.3	16.3	31.8
		n = 970 rpm	kW	4.5	11	21.5	41.9
		n = 1450 rpm	kW	6.8	16.5	32.1	62.7
		n = 1800 rpm	kW	8.4	20.4	39.9	77.8

<sup>1)</sup> Includes 3% loss of displacement

### Control unit MA

Turning the handwheel turns a self-locking threaded spindle which steplessly adjusts the pump's swivel section, and thus the volumetric flow in the range from  $V_{g\ 0}$  to  $V_{g\ max}$ .

### Characteristic

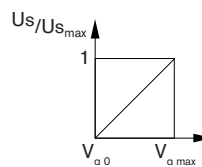

Control unit MA		12	28	55	107
Handwheel turns from $V_{g\ 0}$ to $V_{g\ max}$	$U_s$	10.6	12.7	16	13.4
Max. handwheel adjustment force $F_{max}$	N	70	70	80	120
Mass, approx. (pump with control unit)	kg	19	36	64	117

### Circuit diagram

#### closed circuit

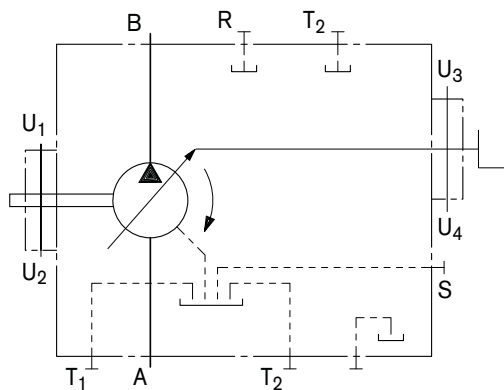

#### open circuit

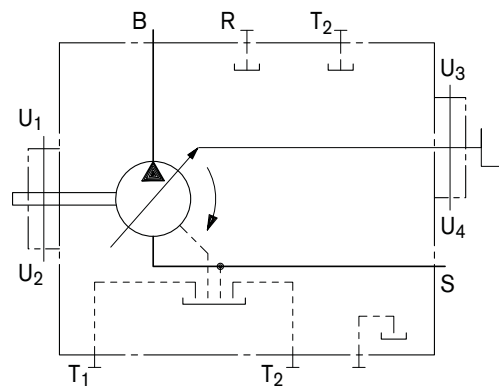

## Dimensions size 12

Before finalizing your design, request a binding installation drawing. Dimensions in mm.

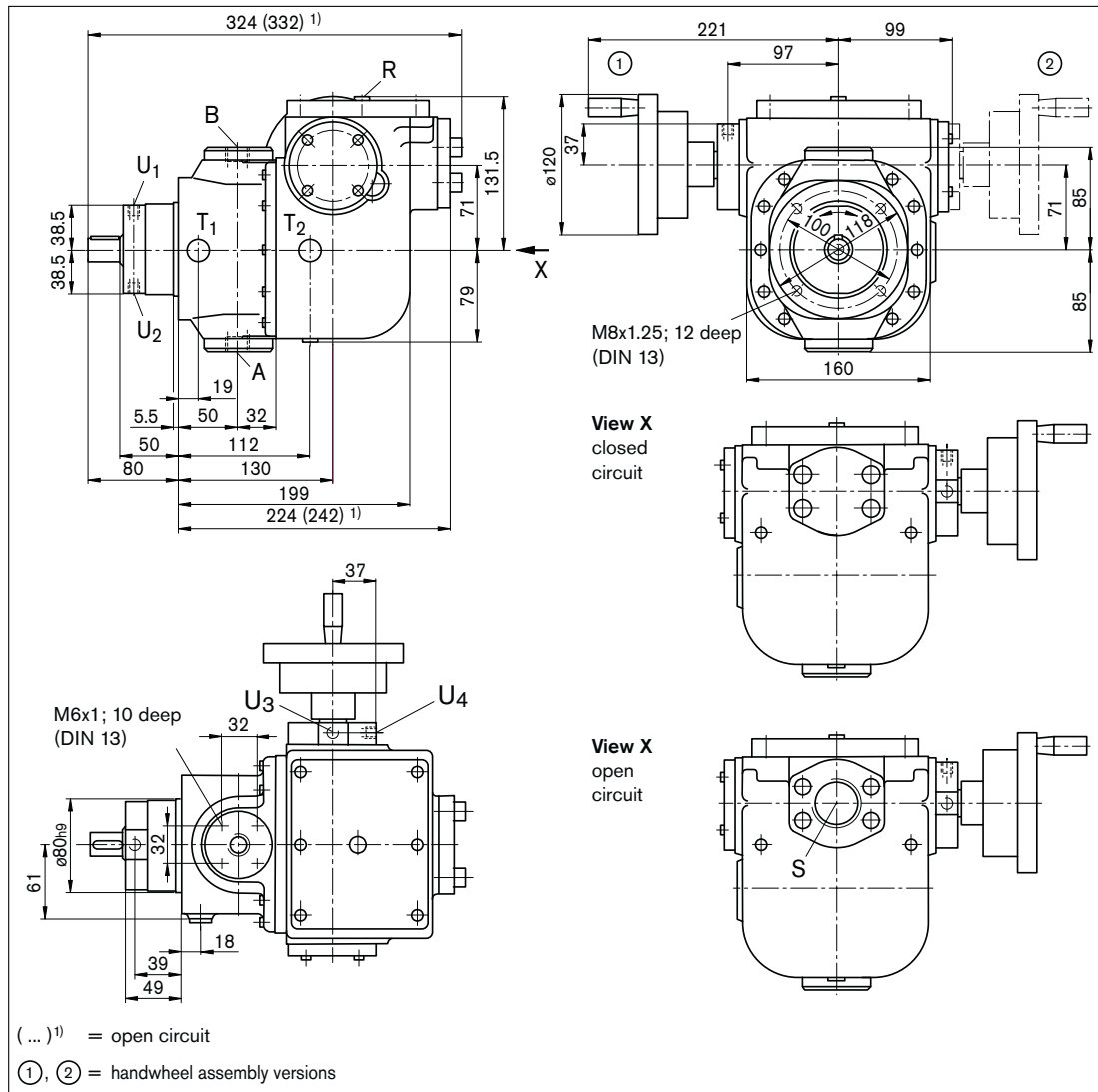

### Ports

Port	Description	Thread	Tightening torque, max.
A, B	Service line ports	M22x1.5 <sup>4)</sup>	210 Nm
S	Suction port <sup>2)</sup>	G1 1/4 <sup>5)</sup>	720 Nm
T <sub>1</sub> , T <sub>2</sub>	Leakage port <sup>3)</sup>	M12x1.5 <sup>4)</sup>	50 Nm
R	Air bleed <sup>3)</sup>	M12x1.5 <sup>4)</sup>	50 Nm
U <sub>1</sub> -U <sub>4</sub>	Ports for buffer fluid	M10x1; 8 deep <sup>4)</sup>	30 Nm

- <sup>2)</sup> plugged in the closed circuit  
<sup>3)</sup> plugged  
<sup>4)</sup> DIN 3852  
<sup>5)</sup> DIN ISO 228  
<sup>6)</sup> centering hole to DIN 332

### Tightening torque, max.

### Drive shaft

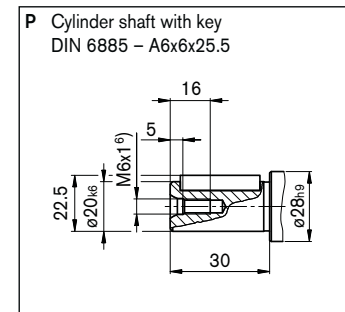

## Dimensions size 28

Before finalizing your design, request a binding installation drawing. Dimensions in mm.

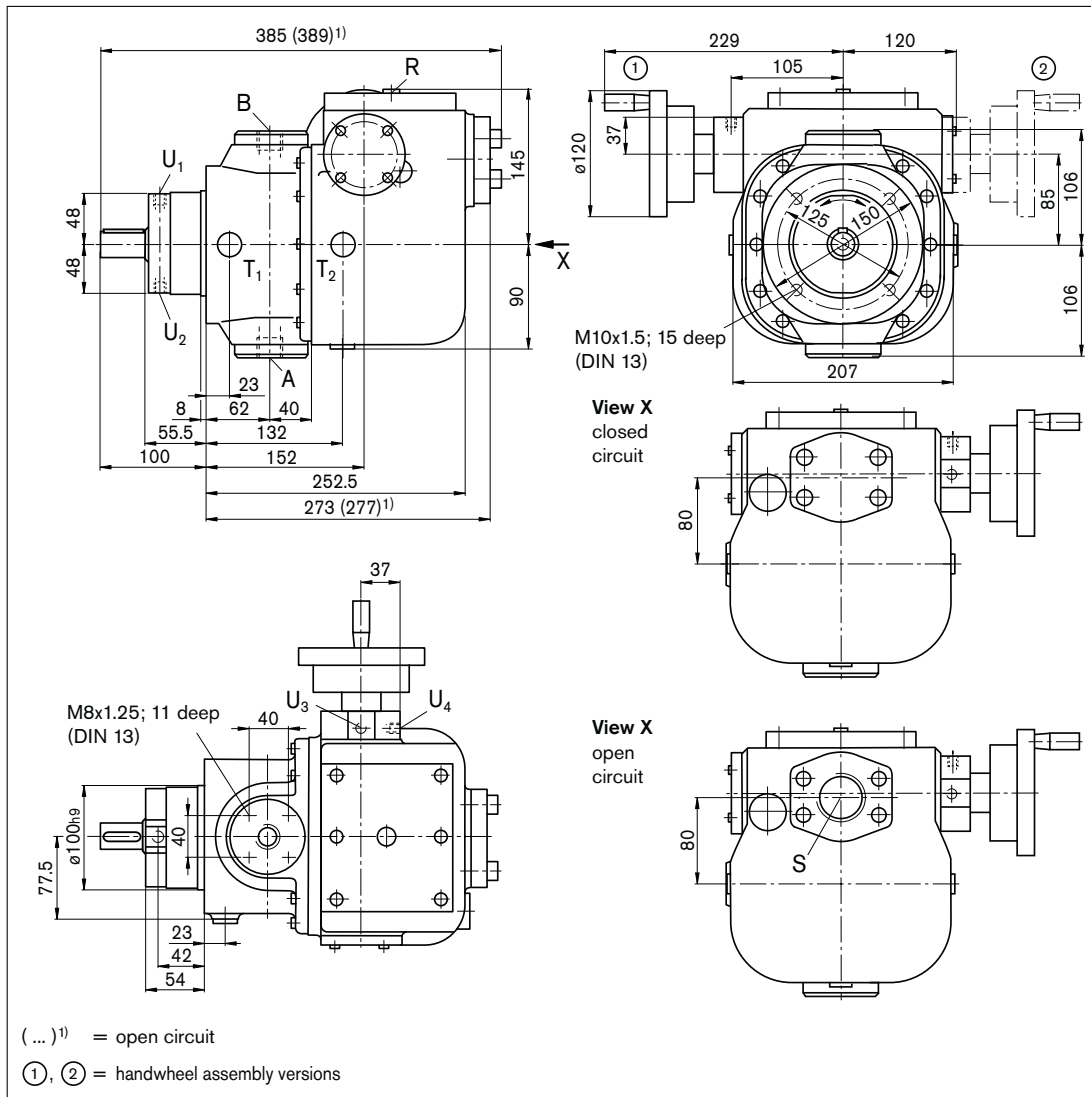

### Ports

Port	Description	Thread	Tightening torque, max.
A, B	Service line ports	M27x2 <sup>4)</sup>	330 Nm
S	Suction port <sup>2)</sup>	G1 1/2 <sup>5)</sup>	960 Nm
T <sub>1</sub> , T <sub>2</sub>	Leakage port <sup>3)</sup>	M16x1.5 <sup>4)</sup>	100 Nm
R	Air bleed <sup>3)</sup>	M12x1.5 <sup>4)</sup>	50 Nm
U <sub>1</sub> -U <sub>4</sub>	Ports for buffer fluid	M10x1; 8 deep <sup>4)</sup>	30 Nm

- <sup>2)</sup> plugged in the closed circuit  
<sup>3)</sup> plugged  
<sup>4)</sup> DIN 3852  
<sup>5)</sup> DIN ISO 228  
<sup>6)</sup> centering hole to DIN 332

### Drive shaft

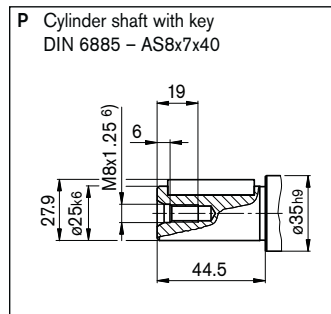



## Dimensions size 107

Before finalizing your design, request a binding installation drawing. Dimensions in mm.

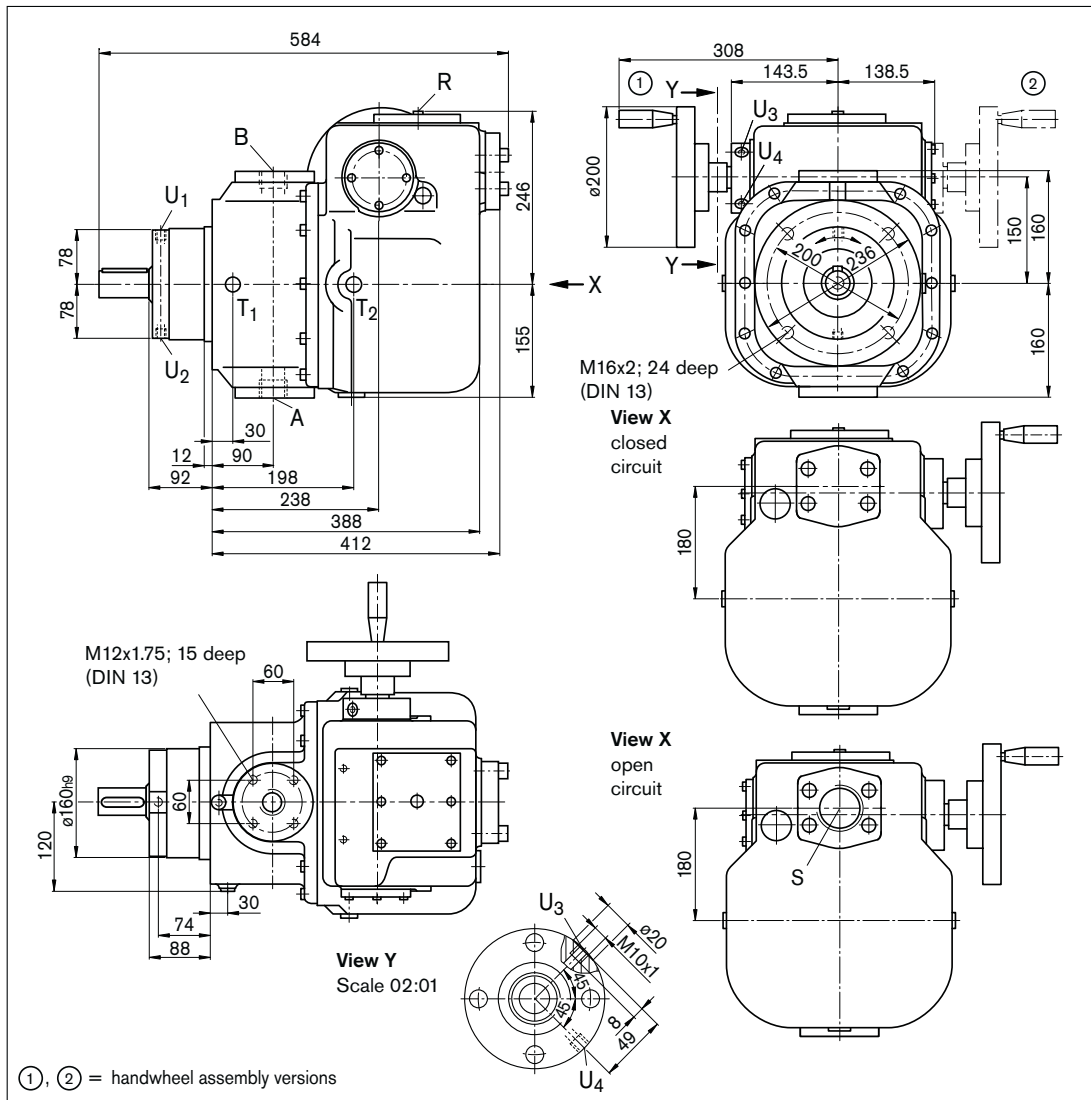

### Ports

Label	Description	Thread	Tightening torque, max.
A, B	Service line ports	M42x2 <sup>3)</sup>	720 Nm
S	Suction port <sup>1)</sup>	G2 1/2 <sup>4)</sup>	2000 Nm
T <sub>1</sub> , T <sub>2</sub>	Leakage port <sup>2)</sup>	M18x1.5 <sup>3)</sup>	140 Nm
R	Air bleed <sup>2)</sup>	M12x1.5 <sup>3)</sup>	50 Nm
U <sub>1</sub> -U <sub>4</sub>	Ports for buffer fluid	M10x1; 8 deep <sup>3)</sup>	30 Nm

- 1) plugged in the closed circuit
- 2) plugged
- 3) DIN 3852
- 4) DIN ISO 228
- 5) centering hole to DIN 332

### Drive shaft

P Cylinder shaft with key  
DIN 6885 - AS12x8x63

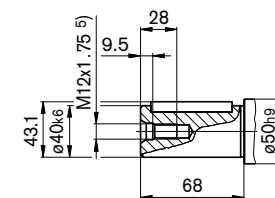

## Pressure limiting valve attached

Before finalizing your design, request a binding installation drawing. Dimensions in mm.

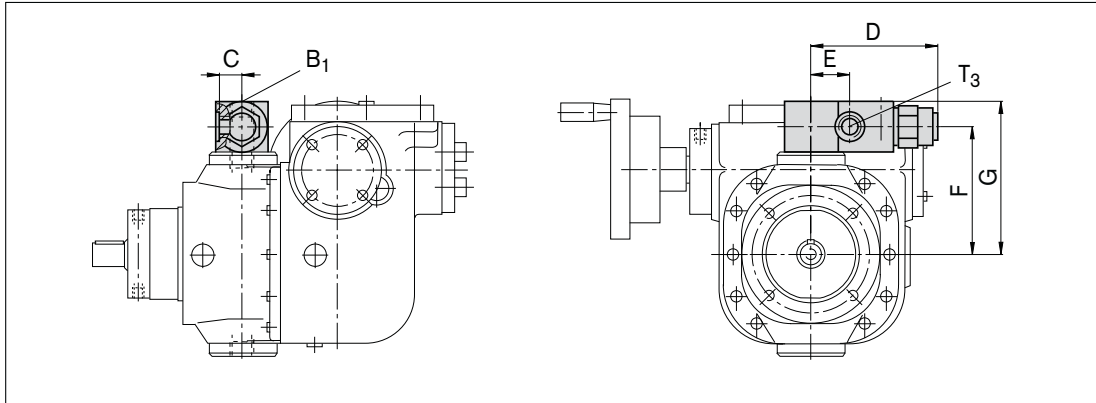

Size	C	D	E	F	G	Service line port B <sub>1</sub> <sup>1)</sup>	Tightening torque, max.	Return port T <sub>3</sub> <sup>1)</sup>	Tightening torque, max.
12	25	109	32	108	131	M22x1.5; 14 deep	210 Nm	M18x1.5; 12 deep	140 Nm
28	26.5	121	40	131	156	M27x2; 16 deep	330 Nm	M22x1.5; 14 deep	210 Nm
55	31.5	133.5	46	160.5	188.5	M33x2; 18 deep	540 Nm	M27x2; 16 deep	330 Nm
107	38.5	174	58	192.5	225	M42x2; 20 deep	720 Nm	M33x2; 20 deep	540 Nm

<sup>1)</sup> DIN 3852

## Notes

## Notes

## General instructions

- The pump A2VK is designed for use in an open or closed circuit.
- Configuration, assembly, commissioning of the pump must be performed by trained and qualified personnel.
- The operating and function ports are designed exclusively for connecting fluid lines.
- Tightening torques: The tightening torques specified in this data sheet are maximum values and may not be exceeded (maximum value for screw thread). Manufacturer specifications for the max. permissible tightening torques of the used fittings must be observed!  
For DIN 13 fastening screws we recommend checking the tightening torque individually according to VDI 2230 Edition 2003.
- The housing temperature rises during and shortly after operation. Take suitable safety precautions (e.g. wear protective clothing).
- Observe the specified data and instructions.
- During maintenance and disposal, please note that the fluids used are potentially harmful to the health. The instructions issued by the fluid manufacturer must be followed.

© This document, as well as the data, specifications and other information set forth in it, are the exclusive property of Bosch Rexroth AG. It may not be reproduced or given to third parties without its consent.

The data specified above only serve to describe the product. No statements concerning a certain condition or suitability for a certain application can be derived from our information. The information given does not release the user from the obligation of own judgment and verification. It must be remembered that our products are subject to a natural process of wear and aging.  
Subject to change.