

## CARR LANE SIMPLEX HAMMERS

SEE COMPONENT PAGES FOR MATERIAL SPECIFICATIONS



Wooden  
Handle



Fiberglass  
Handle

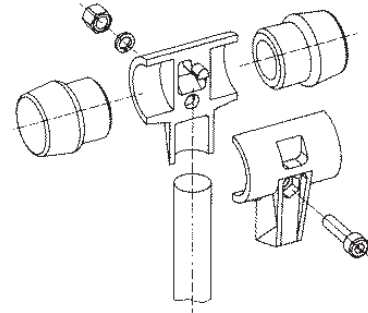

Design your own custom hammers. These soft-face mallets can be customized for specific applications by selecting the proper hammer inserts. Choose the same type of insert for both sides, or build a multi-purpose hammer with a different type of insert for each face. The Simplex system uses a patented hammer housing with 3-point clamping that ensures a safe hammer assembly.

Available in four sizes, with a choice of eight different insert materials:

- Type A Blue Thermoplastic (Soft)
- Type B Gray Thermoplastic (Medium Soft)
- Type C Black Rubber (Medium Soft)
- Type D White Superplastic (Medium Hard)
- Type E Red Plastic (Hard)
- Type F White Nylon (Hard)
- Type G Soft Metal (Hard)
- Type H Copper (Hard) Fiberglass Handle Only

To order a 30mm hammer with a wooden handle, one black rubber insert (C) and one white nylon insert (F) specify:

CL-30-SPH-W-CF

Observe all appropriate safety precautions. Always wear safety goggles when using a hammer or any striking tool. Bystanders must also wear safety goggles. Never strike the hammer with or against another striking tool, hardened nail, or any other hard object that could cause damage. Chipping could occur, resulting in possible eye or other injury. Discard any chipped or damaged hammer. If assembling the hammer yourself, ensure that all parts are properly fitted into the handle housing and that the screw is tightened to the specified torque. Check hammer before each use. Using a hammer with loose or improperly fitted parts could result in serious injury. Use only genuine Simplex replacement components.

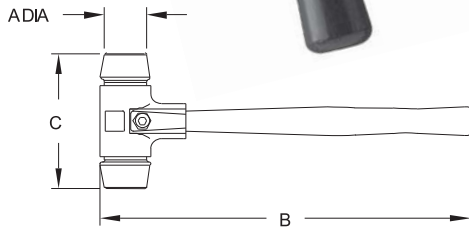

### SIMPLEX HAMMER ASSEMBLY — WOODEN HANDLE

PART NO.	A DIA	B	C	WEIGHT (LBS)
CL-30-SPH-W-xx	30mm (1.18)	11.81	3.54	0.7-0.9
CL-40-SPH-W-xx	40mm (1.57)	12.99	4.33	1.3-1.6
CL-50-SPH-W-xx	50mm (1.96)	13.78	5.32	2.4-3.0
CL-60-SPH-W-xx	60mm (2.36)	15.95	5.71	3.1-4.3

### SIMPLEX HAMMER ASSEMBLY — FIBERGLASS HANDLE

PART NO.	A DIA	B	C	WEIGHT (LBS)
CL-30-SPH-F-xx	30mm (1.18)	11.81	3.54	0.9-1.5
CL-40-SPH-F-xx	40mm (1.57)	12.99	4.33	1.8-3.1
CL-50-SPH-F-xx	50mm (1.96)	13.78	5.32	3.3-4.0
CL-60-SPH-F-xx	60mm (2.36)	15.95	5.71	3.5-5.5

## CARR LANE SIMPLEX HAMMERS



**Type A Inserts**  
Blue Thermoplastic  
(Soft)

Blue thermoplastic inserts are soft and non-smudging. Applications include assembly operations, dent removal, woodworking, furniture assembly, window and door construction, joiner's work, and floor tiling. Hardness 60-70 Shore A.

PART NO.	HAMMER SIZE (FACE DIA)
CL-30-SPH-A	30mm (1.18)
CL-40-SPH-A	40mm (1.57)
CL-50-SPH-A	50mm (1.96)
CL-60-SPH-A	60mm (2.36)



**Type B Inserts**  
Grey Thermoplastic  
(Medium Soft)

Gray thermoplastic inserts are medium soft and non-smudging. Applications include assembly operations, car-body work, woodworking, furniture assembly, window and door construction, joiner's work, floor tiling, paving, and interior construction. Hardness 85-95 Shore A.

PART NO.	HAMMER SIZE (FACE DIA)
CL-30-SPH-B	30mm (1.18)
CL-40-SPH-B	40mm (1.57)
CL-50-SPH-B	50mm (1.96)
CL-60-SPH-B	60mm (2.36)



**Type C Inserts**  
Black Rubber  
(Medium Soft)

Black Rubber inserts are medium soft. Applications include assembly operations, dent removal, prefabricated housing construction, carpenter's work, paving, masonry work, concrete-form setup, scaffold construction, gardening, landscaping, and interior construction. Hardness 90-100 Shore A.

PART NO.	HAMMER SIZE (FACE DIA)
CL-30-SPH-C	30mm (1.18)
CL-40-SPH-C	40mm (1.57)
CL-50-SPH-C	50mm (1.96)
CL-60-SPH-C	60mm (2.36)



**Type D Inserts**  
White Superplastic  
(Medium Hard)

White superplastic inserts (UHMW polyethylene) are medium hard, durable, impact resistant, acid and lye resistant, grease and oil resistant, and ideal for striking sharp edges. Applications include assembly operations, automotive assembly and repair work, repair and maintenance work, car body work, sheet metal working, dent removal, assembly of sharp-edged workpieces, paving, masonry work, scaffold construction, gardening, and landscaping. Hardness 60-70 Shore D.

PART NO.	HAMMER SIZE (FACE DIA)
CL-30-SPH-D	30mm (1.18)
CL-40-SPH-D	40mm (1.57)
CL-50-SPH-D	50mm (1.96)
CL-60-SPH-D	60mm (2.36)



**Type E Inserts**  
Red Plastic  
(Hard)

Red plastic inserts (cellulose acetate) are hard, semi-transparent, and grease and oil resistant. Applications include automotive assembly and repair work, sheet metal working, dent removal, concrete-form setup, and scaffold construction. Hardness 65-75 Shore D.

PART NO.	HAMMER SIZE (FACE DIA)
CL-30-SPH-E	30mm (1.18)
CL-40-SPH-E	40mm (1.57)
CL-50-SPH-E	50mm (1.96)
CL-60-SPH-E	60mm (2.36)



**Type F Inserts**  
White Nylon  
(Hard)

White nylon inserts are hard, grease and oil resistant, highly elastic, and have superior strike effectiveness. Applications include assembly operations, metalworking, tooling, automotive assembly and repair work, joining of workpieces, sheet metal working, dent removal, mold construction, assembly of sharp-edged workpieces, and scaffold construction. Hardness 68-78 Shore D.

PART NO.	HAMMER SIZE (FACE DIA)
CL-30-SPH-F	30mm (1.18)
CL-40-SPH-F	40mm (1.57)
CL-50-SPH-F	50mm (1.96)
CL-60-SPH-F	60mm (2.36)



**Type G Inserts**  
Soft Metal  
(Hard)

Soft metal inserts are made of an aluminum-copper alloy which is hard and resistant to heat. Excellent alternative to old-fashioned lead hammers, to eliminate the risk of lead contamination. Applications include metalworking, tooling, automotive assembly and repair work, straightening work, car body work, and mold construction.

PART NO.	HAMMER SIZE (FACE DIA)
CL-30-SPH-G	30mm (1.18)
CL-40-SPH-G	40mm (1.57)
CL-50-SPH-G	50mm (1.96)
CL-60-SPH-G	60mm (2.36)



**Type H Inserts**  
Copper  
(Hard)

Copper inserts are hard and provide maximum impact. Plastic socket provides for secure mounting of the copper insert in the hammer. Applications include machine construction, automotive assembly and repair work, repair and maintenance work, and vehicle service stations.

PART NO.	HAMMER SIZE (FACE DIA)
CL-30-SPH-H	30mm (1.18)
CL-40-SPH-H	40mm (1.57)

## CARR LANE SIMPLEX HAMMERS

HOUSINGS: CAST IRON, FURNISHED WITH SOCKET-HEAD CAP SCREW, SPRING WASHER, AND NUT  
HANDLES: EUROPEAN BLACK LOCUST WOOD, OR FIBERGLASS WITH ERGONOMIC RUBBER GRIP



Rugged cast iron housing (red), furnished with a high-strength Socket-Head Cap Screw, spring washer, and nut. Premium quality hardwood handle. Use wooden handles only with red housings.



### HOUSING & HANDLE — WOODEN HANDLE

HOUSING PART NO.	HANDLE PART NO.	HAMMER SIZE (FACE DIA)	TIGHTENING TORQUE (FT-LBS)	
			PLASTIC INSERTS	METAL INSERTS
CL-30-SPH-HWH	CL-30-SPH-WH	30mm (1.18)	11	15
CL-40-SPH-HWH	CL-40-SPH-WH	40mm (1.57)	18	30
CL-50-SPH-HWH	CL-50-SPH-WH	50mm (1.96)	22	37
CL-60-SPH-HWH	CL-60-SPH-WH	60mm (2.36)	30	48



Heavy-duty cast iron housing (black), reinforced for use with a fiberglass handle, furnished with a high-strength Socket-Head Cap Screw, spring washer, and nut. High-strength fiberglass handle with an ergonomic rubber grip. Use fiberglass handles only with black housings.



### HOUSING & HANDLE — FIBERGLASS HANDLE

HOUSING PART NO.	HANDLE PART NO.	HAMMER SIZE (FACE DIA)	TIGHTENING TORQUE (FT-LBS)	
			PLASTIC INSERTS	METAL INSERTS
CL-30-SPH-HFH	CL-30-SPH-FH	30mm (1.18)	18	30
CL-40-SPH-HFH	CL-40-SPH-FH	40mm (1.57)	22	44
CL-50-SPH-HFH	CL-50-SPH-FH	50mm (1.96)	30	52
CL-60-SPH-HFH	CL-60-SPH-FH	60mm (2.36)	44	59

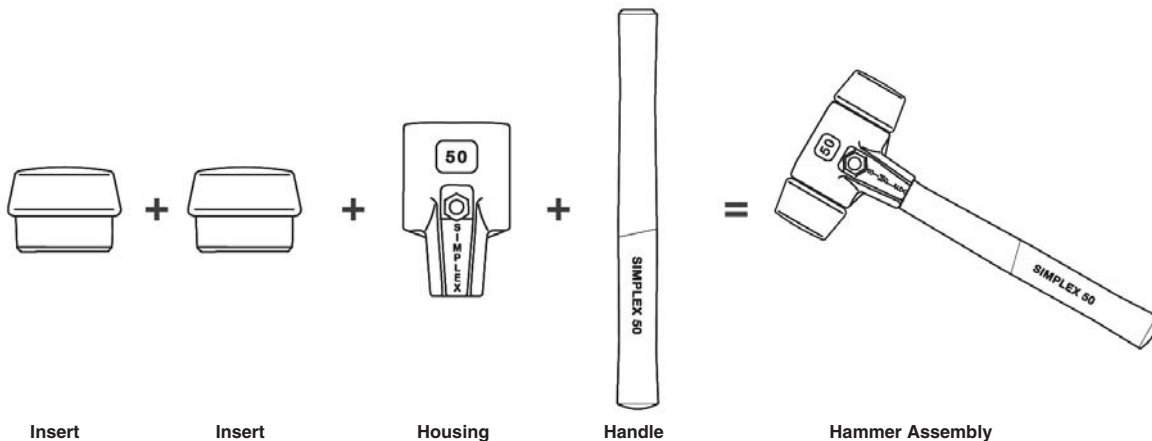

Insert

Insert

Housing

Handle

Hammer Assembly

## NO-REBOUND HAMMERS

HOUSINGS: STEEL ASSEMBLY CONTAINING STEEL PELLETS. HANDLE: HICKORY WOOD.  
INSERTS: NYLON, NATURAL WHITE COLOR, HARDNESS 68-78 SHORE D



**Supercraft  
Hammers  
(Wooden Handle)**

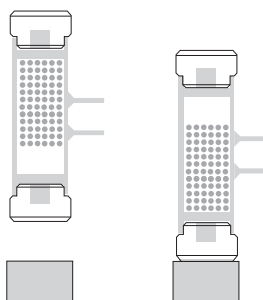

No-Rebound Hammers are filled with special steel pellets that transfer momentum to the impact point.

No-Rebound Hammers deliver full impact, about 50% greater than a standard hammer. The housing is filled with special steel pellets that transfer momentum to the impact point. Ideal for assembling machine parts without damage. Speeds up work while reducing fatigue. Allows better hammer control by absorbing the bounce. Hickory-wood handle. Available in five standard sizes, plus two sledgehammer sizes.

Supercraft No-Rebound Hammers have replaceable nylon inserts. These nylon inserts are hard, grease and oil resistant, highly elastic, and have superior strike effectiveness. Applications include assembly operations, metalworking, tooling, positioning of workpieces, automotive assembly and repair work, joining of workpieces, sheet metal working, dent removal, mold construction, assembly of sharp-edged workpieces, and scaffold construction.

Observe all appropriate safety precautions. Never allow the hammer's striking faces to wear down to the point where the hammer housing makes contact with the work surface, as irreparable damage could result. Always wear safety goggles when using a hammer or any striking tool. Bystanders must also wear safety goggles. Never strike the hammer with or against another striking tool, hardened nail, or any other hard object that could cause damage. Chipping could occur, resulting in possible eye or other injury. Discard any chipped or damaged hammer.

### SUPERCRAFT HAMMERS — WOODEN HANDLE

PART NO.	FACE DIA	WEIGHT (LBS)	OVERALL LENGTH	HEAD LENGTH	REPLACEMENT INSERT (2 REQUIRED)
CL-3366-020-NRH	20mm (.78)	0.5	11.77	4.12	CL-3508-020-NRHI
CL-3366-030-NRH	30mm (1.18)	0.7	12.95	4.32	CL-3508-030-NRHI
CL-3366-040-NRH	40mm (1.57)	1.6	14.13	4.51	CL-3508-040-NRHI
CL-3366-050-NRH	50mm (1.96)	2.2	14.52	4.71	CL-3508-050-NRHI
CL-3366-060-NRH	60mm (2.36)	3.8	14.52	5.69	CL-3508-060-NRHI



**Supercraft  
Sledgehammers  
(Wooden Handle)**

### SUPERCRAFT SLEDGEHAMMERS — WOODEN HANDLE

PART NO.	FACE DIA	WEIGHT (LBS)	OVERALL LENGTH	HEAD LENGTH	REPLACEMENT INSERT (2 REQUIRED)
CL-3366-081-NRH	80mm (3.14)	9	34.5	7.85	CL-3508-080-NRHI
CL-3366-107-NRH	100mm (3.93)	15	39.2	8.24	CL-3508-100-NRHI

## NO-REBOUND HAMMERS

HOUSING & HANDLE: STEEL ASSEMBLY CONTAINING STEEL PELLETS  
SUPERCRAFT INSERTS: NYLON, NATURAL WHITE COLOR, HARDNESS 68-78 SHORE D  
SECURAL INSERTS: POLYURETHANE, YELLOW



**Supercraft  
Hammers  
(Steel Handle)**



**Secural  
Narrow Hammers  
(Steel Handle)**

No-Rebound Hammers deliver full impact, about 50% greater than a standard hammer. The housing is filled with special steel pellets that transfer momentum to the impact point. Ideal for assembling machine parts without damage. Speeds up work while reducing fatigue. Allows better hammer control by absorbing the bounce. Steel handle with ergonomic rubber grip.

Supercraft No-Rebound Hammers are available in four sizes. Supercraft Hammers have replaceable nylon inserts. These nylon inserts are hard, grease and oil resistant, highly elastic, and have superior strike effectiveness.

Secural Narrow No-Rebound Hammers have a narrow, rectangular head that allows hammering in tight spots, and also makes storage easier in toolbox drawers. Available in one size, with a 30mm x 40mm face. Secural Narrow Hammers have replaceable polyurethane inserts. These inserts are medium soft.

Observe all appropriate safety precautions. Never allow the hammer's striking faces to wear down to the point where the hammer housing makes contact with the work surface, as irreparable damage could result. Always wear safety goggles when using a hammer or any striking tool. Bystanders must also wear safety goggles. Never strike the hammer with or against another striking tool, hardened nail, or any other hard object that could cause damage. Chipping could occur, resulting in possible eye or other injury. Discard any chipped or damaged hammer.

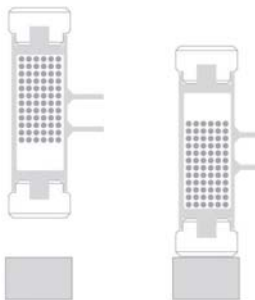

No-Rebound Hammers are filled with special steel pellets that transfer momentum to the impact point.

### SUPERCRAFT HAMMERS — STEEL HANDLE

PART NO.	FACE DIA	WEIGHT (LBS)	OVERALL LENGTH	HEAD LENGTH	REPLACEMENT INSERT (2 REQUIRED)
CL-3377-030-NRH	30mm (1.18)	1.3	11.38	4.32	CL-3508-030-NRHI
CL-3377-040-NRH	40mm (1.57)	1.9	11.77	4.51	CL-3508-040-NRHI
CL-3377-050-NRH	50mm (1.96)	2.6	12.17	4.71	CL-3508-050-NRHI
CL-3377-060-NRH	60mm (2.36)	3.9	12.76	5.69	CL-3508-060-NRHI

### SECURAL NARROW HAMMERS — STEEL HANDLE

PART NO.	FACE DIMENSIONS (RECTANGULAR)	WEIGHT (LBS)	OVERALL LENGTH	HEAD LENGTH	REPLACEMENT INSERT (2 REQUIRED)
CL-3380-040-NRH	30mm x 40mm (1.18 x 1.57)	1.6	11.77	4.59	CL-3511-040-NRHI

## NO-REBOUND DROP HAMMERS

HOUSING: STEEL ASSEMBLY CONTAINING STEEL PELLETS  
INSERTS: NYLON, NATURAL WHITE COLOR, HARDNESS 68-78 SHORE D

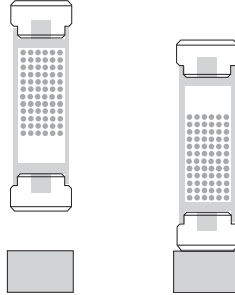

No-Rebound Drop Hammers are filled with special steel pellets that transfer momentum to the impact point.

No-Rebound Drop Hammers provide the impact of a normal hammer even when access is restricted. No-Rebound Hammers deliver full impact, about 50% greater than a standard hammer. The housing is filled with special steel pellets that transfer momentum to the impact point. Ideal for assembling machine parts without damage. Speeds up work while reducing fatigue. Allows better hammer control by absorbing the bounce. Available in four sizes.

No-Rebound Drop Hammers have replaceable nylon inserts. These nylon inserts are hard, grease and oil resistant, highly elastic, and have superior strike effectiveness. Applications include assembly operations, metalworking, tooling, positioning of workpieces, automotive assembly and repair work, joining of workpieces, sheet metal working, dent removal, mold construction, and assembly of sharp-edged workpieces.

PART NO.	FACE DIA	WEIGHT (LBS)	LENGTH	REPLACEMENT INSERT (2 REQUIRED)
CL-3408-020-NRH	20mm (.78)	0.5	5.89	CL-3508-020-NRHI
CL-3408-030-NRH	30mm (1.18)	1.0	6.08	CL-3508-030-NRHI
CL-3408-040-NRH	40mm (1.57)	1.8	6.28	CL-3508-040-NRHI
CL-3408-050-NRH	50mm (1.96)	2.8	6.48	CL-3508-050-NRHI

## SOFT-FACE PUNCHES

HOUSING: STEEL. INSERTS: NYLON, NATURAL WHITE COLOR, HARDNESS 68-78 SHORE D



Soft-Face Punches safely extend the reach of a hammer when access is restricted. Transfers impact to difficult-to-reach places. Available in two sizes.

Soft-Face Punches have replaceable nylon inserts. These nylon inserts are hard, grease and oil resistant, highly elastic, and have superior strike effectiveness. Applications include assembly operations, metalworking, tooling, automotive assembly and repair work, joining of workpieces, sheet metal working, dent removal, and assembly of sharp-edged workpieces.

PART NO.	FACE DIA	WEIGHT (LBS)	LENGTH	REPLACEMENT INSERT (2 REQUIRED)
CL-3408-010-SFP	10mm (.39)	0.2	6.59	CL-3508-010-NRHI
CL-3408-015-SFP	15mm (.59)	0.4	6.87	CL-3508-015-NRHI