



## ROEMHELD

Issue 12-01 E

# B 1.885

### Swing Clamps

with overload protection device, single acting with spring return  
max. operating pressure 500 bar

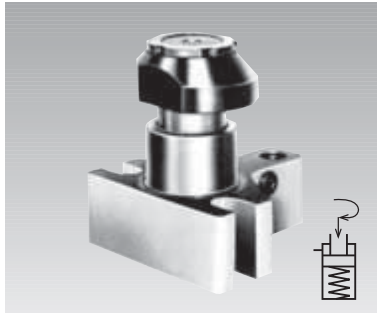

#### Application

These swing clamps are used when it is required to keep the fixture workpiece area free of straps and clamping components for unrestricted workpiece loading and unloading.

The special shape of the body of this swing clamp range with their low installation height are ideal for direct mounting onto machine tool tables or fixture bodies.

#### Function

This hydraulic clamping element is a pull-type cylinder where a part of the total stroke is used to swing the piston. The larger part of the stroke is available as clamping stroke.

#### Overload protection device

An integrated mechanical overload protection device prevents damage to the swing mechanism when striking an object within the 90° rotation, clamping or unclamping alike, or in case of incorrect mounting of the clamping arm.

#### Variants of swing clamps

Standard angles of rotation are 45°, 60°, and 90° ± 2°.

Other variants, as e.g. versions with metallic wiper on request.

#### Note

Operating conditions, tolerances and other data see data sheet A 0.100.

#### Versions

The units are available in three standard sizes, and for each size three versions of standard clamping arms are available (accessories see page 3). Mounting of these clamping arms at any angle within 360°. All units are equipped with piston rod wipers. A connecting possibility for a hose to bleed the piston area is provided.

#### Material

By nitrating piston and housing, wear is reduced and protection against corrosion increased.

Piston material: high alloy steel  
Cylinder body: SG cast iron.

#### Application examples

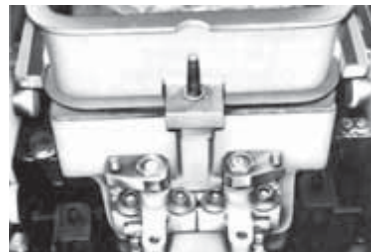

This figure shows a hydraulic swing clamp on a cast moulding machine, holding the pattern plates. Clamping and unclamping can be effected in seconds via a push-button.

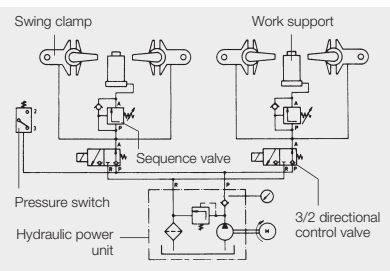
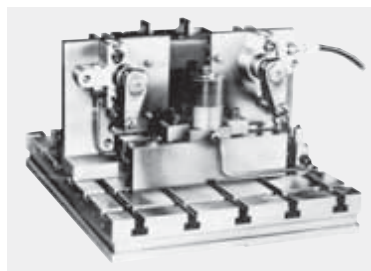

This above installation is almost exclusively built from standard elements. Castings made of GG are clamped, which are being milled and bored in pendulum on a NC machining centre. As the hydraulic circuit diagram shows, first the swing clamps are actuated and then, via a sequence valve, the work supports are extended and locked. The clamping and support points are completely retracted for unloading the workpiece.



## ROEMHELD

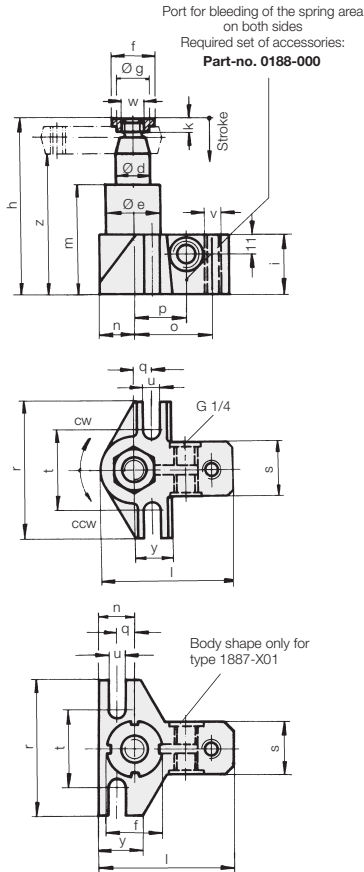

Total stroke	[mm]	14	16	20
Stroke to swing	[mm]	7	8	9
Stroke to clamp	[mm]	7	8	11
Operating pressure, min.	[bar]	30	30	30
<b>Max. oil flow rate *</b>	[cm <sup>3</sup> /s]	3.2	10	27.7
Oil volume/stroke	[cm <sup>3</sup> ]	2.5	7.3	23
Ø d	[mm]	20	32	50
Ø e -0.05	[mm]	32	50	70
f	[mm]	39	40	68
Ø g	[mm]	23.5	33.5	55.5
h	[mm]	103	120	158
i	[mm]	40	45	55
k	[mm]	9	10	12
l	[mm]	76	120	152
m	[mm]	65	75	97.5
n	[mm]	20	28	42
o	[mm]	45	75	90
p	[mm]	30	50	60
q	[mm]	8	15	17
r	[mm]	80	120	140
s	[mm]	30	34	40
t <sup>2)</sup>	[mm]	47	74	100
u	[mm]	9	17	21
v	[mm]	M 10	M 16	M 20
w	[mm]	M 18 x 1.5	M 28 x 1.5	M 45 x 1.5
y	[mm]	20	40	52
z -1	[mm]	82	92	118 (121)❖
Weight	[kg]	1.0	2.6	6.1
Clockwise rotation	<b>Part-no.</b>	<b>1883-101</b>	<b>1885-101</b>	<b>1887-101</b>
Counterclockwise rotation	<b>Part-no.</b>	<b>1883-201</b>	<b>1885-201</b>	<b>1887-201</b>

Angle of rotation	<b>Part-no.</b>
90°	188X-X01
60°	188X-X21
45°	188X-X31
0°	188X-X41

<sup>2)</sup>t = min. distance of screws, if screws as per DIN 912 and washers as per DIN 433 are used.

❖ (121) for clamping strap 0354-004

\* The max. oil flow rate is valid for vertical mounting position in connection with standard clamping arms. In the case that other mounting positions and/or other clamping arms are used, the oil flow rate **has to be** reduced as necessary. Flow control swivel fittings see data sheet C 2.9501. A possibly required flow control has to be made by a flow control valve in the clamping line.

### Effective clamping force $F_{Sp}$ as function of operating pressure p

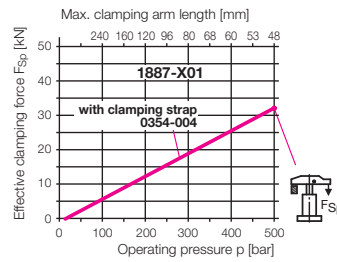
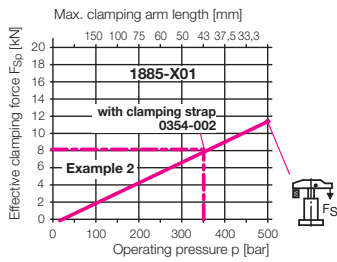
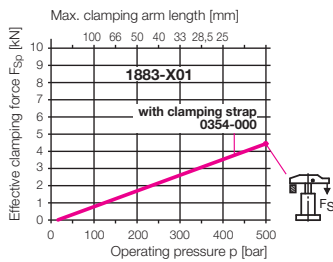
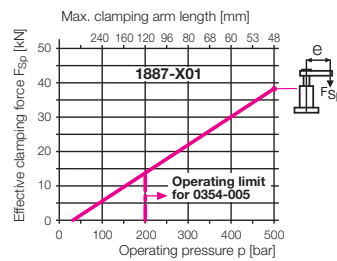
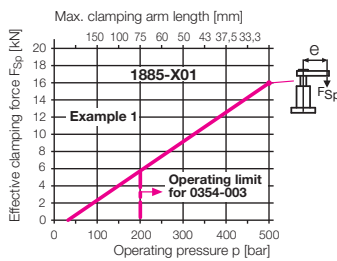
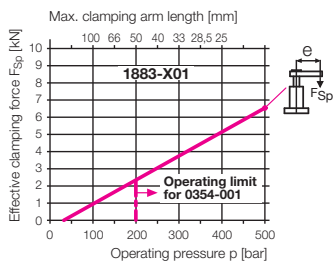

#### Example 1: 1885-001

An operating pressure p of 200 bar in connection with standard clamping arm 0354-003 of max. arm length L = 75 mm results in an effective clamping force  $F_{Sp}$  of 5,8 kN.

#### Example 2:

For a desired effective clamping force  $F_{Sp}$  of 8 kN and use of a swing clamp 1885-101 with a standard clamping strap 0354-002 an operating pressure p of 345 bar is required.



## ROEMHELD

### Accessories

Dimensions  
for special  
clamping arms

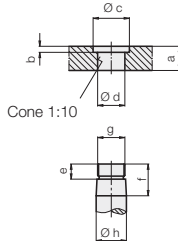

Swing clamp	a	b	∅c	∅d <sup>+0.10 -0.05</sup>	e	f	g	∅h <sub>f7</sub>
1883-XX1	16	4	24	19.8	10	21	M18x1.5	20
1885-XX1	23	5	34	31.8	12	28	M28x1.5	32
1887-XX1	34	6	56	49.8	13	40	M45x1.5	50

Clamping arm,  
max. 500 bar

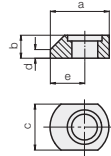

Material:  
42CrMo4

Swing clamp	a	b	c	d	e	Weight [kg]	Part-no.
1883-XX1	41	16	32	6	25	0.08	<b>3548-159</b>
1885-XX1	61	23	48	6	37	0.23	<b>3548-165</b>
1887-XX1	90	34	78	14	52	0.88	<b>3548-163</b>

Clamping arm,  
max. 300 bar

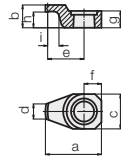

Material:  
42CrMo4

Swing clamp	a	b	c	d	e	f	g	h	i	Weight [kg]	Part-no.
18X3-XX1	51.5	21	32	14	33.5	16	15.5	14.5	7	0.11	<b>3548-238</b>
18X5-XX1	76	28	46	25	50	23	22.5	19	7	0.30	<b>3548-236</b>
18X7-XX1	123	40	75	39	82.5	37.5	34	27	8	1.30	<b>3548-302</b>

Clamping arm  
assembly,  
complete, max. 200  
bar

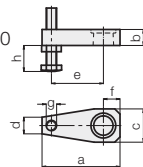

Material:  
42CrMo4

Swing clamp	a	b	c	d	e	f	g	h max.	h min.	Weight [kg]	Part-no.
1883-XX1	75	16	32	16	50	16	M10	64	6	0.2	<b>0354-001</b>
1885-XX1	115	23	48	22	75	25	M16	79	9	0.7	<b>0354-003</b>
1887-XX1	178	34	78	40	120	40	M20	98	12	2.55	<b>0354-005</b>

Swing clamp	a	b	c	d	f	Weight [kg]	Part-no.
1883-XX1	75	16	32	16	16	0.18	<b>3921-016</b>
1885-XX1	115	23	48	22	25	0.65	<b>3921-017</b>
1887-XX1	178	34	78	40	40	2.3	<b>3921-018</b>

Clamping strap  
assembly,  
complete,  
with carrier,  
max. 500 bar

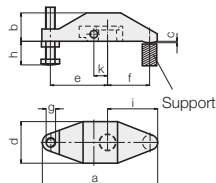

Material:  
GGG-40

Swing clamp	a	b	c	d	e	f	g	h max.	h min.	i	k	Weight [kg]	Part-no.
1883-XX1	122	30	1.5	44	60	45	M10	64	6	53	14.5	0.57	<b>0354-000</b>
1885-XX1	185	45	2	58.5	83	75	M16	79	9	87	21	1.58	<b>0354-002</b>
1887-XX1	223	59	2.5	98	100	90	M20	98	12	105	33	4.75	<b>0354-004</b>

Carrier for special  
clamping strap

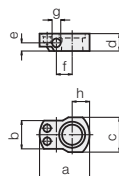

Material:  
C-45

Swing clamp	a±0.1	b	c	d	e	f	g <sup>H7</sup>	h	Weight [kg]	Part-no.
1883-XXX	46	26	32	16	7.5	14.5	8	16	0.08	<b>3542-093</b>
1885-XXX	59	32	40	23	13	21	10	22	0.16	<b>3542-094</b>
1887-XXX	90	56	68	34	21	33	14	36	0.65	<b>3542-096</b>